

XSM □ 55 - 75" MICRO-ADJUSTABLE MOUNT



FUSION® SERIES

FEATURES

- 1 CONTROLZONE™ LEVELING**
Industry-first feature allows post-installation fine tuning of height and leveling, up to 0.5" (13 mm) adjustment up or down.
- 2 CENTERLESS™ SHIFT**
Provides up to 23.5" (597 mm) of post-installation lateral shift - 11.75" (298 mm) left/right of uprights.
- 3 CLICKCONNECT™**
Hear an audible click when the screen safely engages with the mount. A built-in cable stand provides easy access under the screen.
- 4 CUSTOMIZABLE ACCESSORY SYSTEM**
A full line of supporting accessories can be integrated with the mount, extending the same adjustment benefits to the entire configuration.

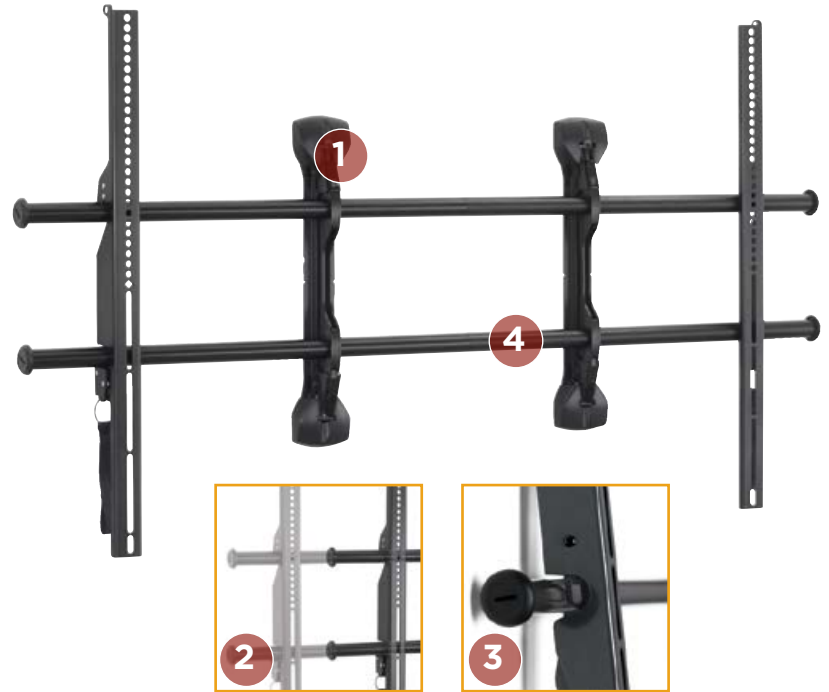

SPECIFICATIONS

Depth from Wall	1.96" (50 mm)
Max Lateral Shift	23.5" (597 mm)
Dimensions (HxWxD)	16.5 x 48.44 x 1.96" (41.9 x 123 x 5 cm)
Max Mounting Pattern (H,W)	25.98" (660 mm) 48.23" (1225 mm)
Weight Capacity	250 lbs (113 kg)
Color	Black

WHAT YOU NEED TO KNOW

MULTIPLE INSTALLATION OPTIONS

Can be installed on 24" on-centers up to 48". For 16" on-centers, span 3 studs.

OTHER PRODUCT OPTIONS

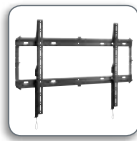

RXF2
FIT™ Series Low-Profile Hinge Mount
- For TVs 40 - 63"



PSMH
Heavy-Duty, Custom Fixed Wall Mount
- For TVs over 60", weight cap. varies per custom model

TECHNICAL DRAWINGS

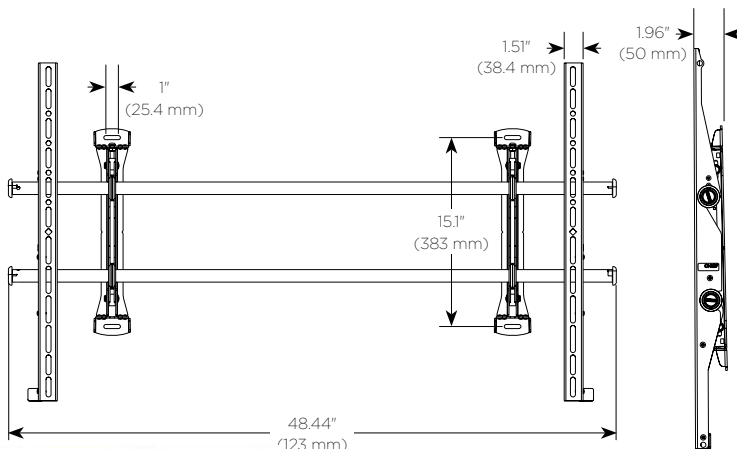

RECOMMENDED ACCESSORIES



FLR100 ■ Left/Right Speaker Adapters



FCC100 ■ Center Channel Speaker Adapters



FCS100 ■ Single Component Shelf
- below

For a complete list of FUSION accessories see pages **86 - 88**.