

---

# INSTALLATION INSTRUCTIONS

---

Instrucciones de instalación  
Installationsanleitung  
Instruções de Instalação

Istruzioni di installazione  
Installatie-instructies  
Instructions d'installation

**Touchboards**

205 Westwood Ave, Long Branch, NJ 07740  
Phone: 866-94 BOARDS (26273) / (732)-222-1511  
Fax: (732)-222-7088 | E-mail: sales@touchboards.com

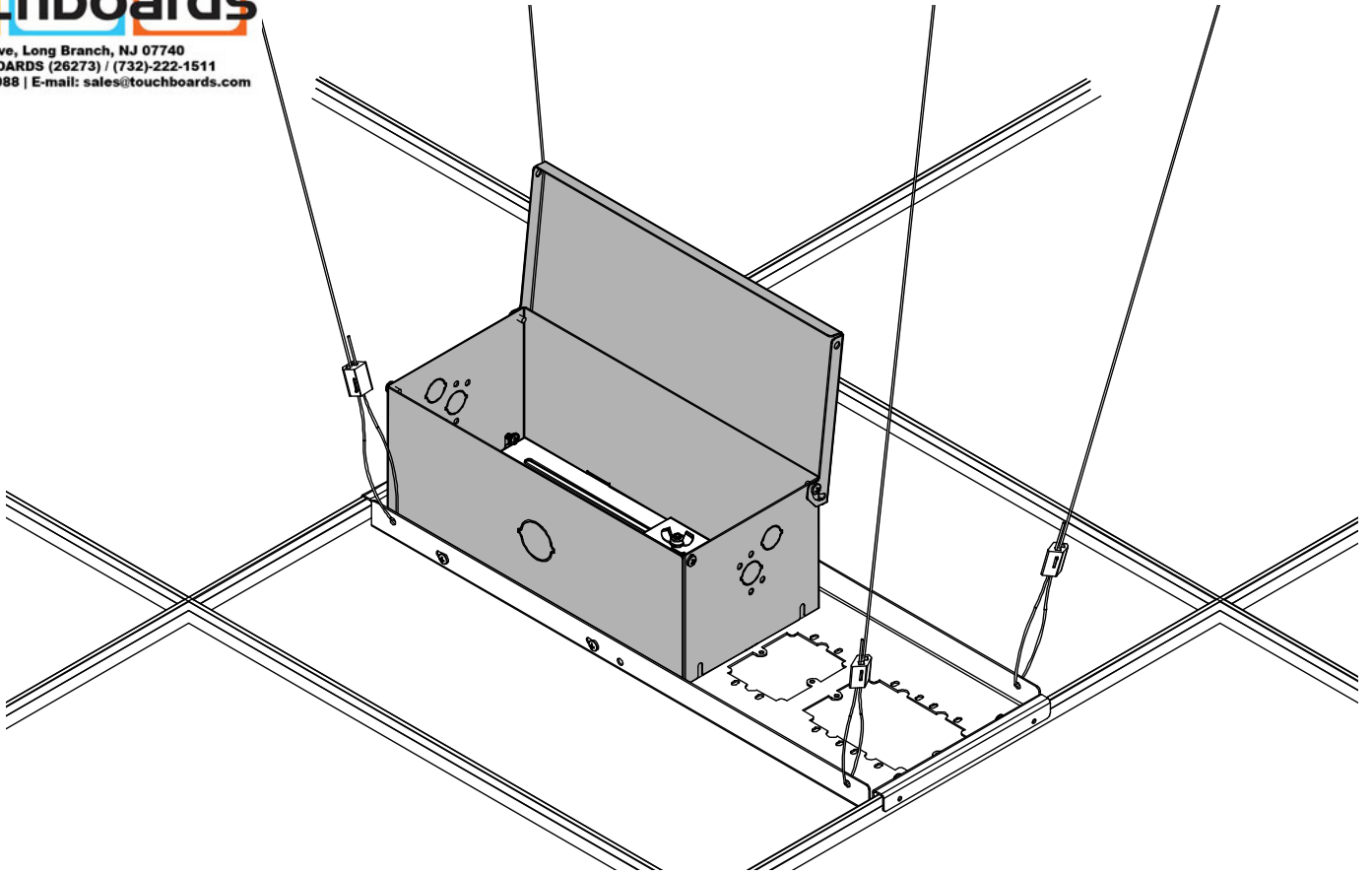

---

## Above-Tile Suspended Ceiling Storage Kit

---

---

**CHIEF**<sup>®</sup>  
Our Mounts. Your Vision.

**CMA470, CMA471**

---

## DISCLAIMER

Milestone AV Technologies, and its affiliated corporations and subsidiaries (collectively, "Milestone"), intend to make this manual accurate and complete. However, Milestone makes no claim that the information contained herein covers all details, conditions or variations, nor does it provide for every possible contingency in connection with the installation or use of this product. The information contained in this document is subject to change without notice or obligation of any kind. Milestone makes no representation of warranty, expressed or implied, regarding the information contained herein. Milestone assumes no responsibility for accuracy, completeness or sufficiency of the information contained in this document.

Chief® is a trademark of Milestone AV Technologies. All rights reserved.

## IMPORTANT WARNINGS AND CAUTIONS!

 **WARNING:** A WARNING alerts you to the possibility of serious injury or death if you do not follow the instructions.

 **CAUTION:** A CAUTION alerts you to the possibility of damage or destruction of equipment if you do not follow the corresponding instructions.

 **WARNING:** Failure to read, thoroughly understand, and follow all instructions can result in serious personal injury, damage to equipment, or voiding of factory warranty! It is the installer's responsibility to make sure all components are properly assembled and installed using the instructions provided.

## ¡AVISOS y PRECAUCIONES IMPORTANTES!

 **AVISO:** Un AVISO llama su atención sobre la posibilidad de sufrir lesiones de gravedad o incluso mortales si no sigue las instrucciones.

 **PRECAUCIÓN:** Una nota de PRECAUCIÓN llama su atención sobre la posibilidad de dañar o destruir el equipo si no sigue las instrucciones.

 **AVISO:** Si no lee, comprende perfectamente y sigue todas las instrucciones, podría causar daños graves personales y materiales o anular la garantía de fábrica. El instalador es el responsable de asegurarse de que todos los componentes están correctamente montados e instalados siguiendo las instrucciones indicadas.

## WICHTIGE WARN- und VORSICHTSHINWEISE!

 **WARNUNG:** Ein WARNHINWEIS macht auf mögliche schwere oder tödliche Verletzungen aufmerksam, die bei Nichtbefolgung der Anweisungen eintreten können.

 **VORSICHT:** Ein VORSICHTSHINWEIS macht auf Schäden oder mögliche Zerstörung des Geräts aufmerksam, die bei Nichtbefolgung der Anweisungen eintreten können.

 **WARNUNG:** Falls nicht alle Anweisungen gelesen und gut verstanden werden, kann dies zu schweren Körperverletzungen, Schaden an den Geräten führen und die Werksgarantie nichtig machen! Der Monteur ist dafür verantwortlich, dass alle Komponenten unter Einhaltung der mitgelieferten Anweisungen korrekt zusammengebaut und eingebaut werden.

## ADVERTÊNCIAS e AVISOS IMPORTANTES!

 **ADVERTÊNCIA:** Os alertas de ADVERTÊNCIA avisam-no para a possibilidade de ocorrência de graves lesões ou morte no caso de incumprimento das instruções.

 **AVISO:** Os alertas de AVISO avisam-no para a possibilidade de danos ou destruição do equipamento no caso de incumprimento das instruções.

 **ADVERTÊNCIA:** Se não ler, compreender completamente e seguir todas as instruções podem ocorrer graves lesões pessoais, danos no equipamento e a garantia de fábrica pode ser anulada! É da responsabilidade do instalador certificar-se de que todos os componentes são correctamente montados e instalados de acordo com as instruções fornecidas.

## AVVERTENZE e PRECAUZIONI IMPORTANTI!

 **AVVERTENZA:** Un'AVVERTENZA mette in guardia in merito alla possibilità di gravi infortuni, anche letali, qualora non si osservino le istruzioni.

 **ATTENZIONE:** Un'ATTENZIONE indica la possibilità di gravi danni all'attrezzatura qualora non ci si attiene alle istruzioni al riguardo.



**AVVERTENZA:** La mancata comprensione e ottemperanza alle istruzioni fornite può provocare gravi lesioni personali, danni all'apparecchiatura o annullare la garanzia fornita dal produttore. Spetta all'installatore verificare che tutti i componenti siano assemblati correttamente e installati secondo le istruzioni fornite.



### **BELANGRIJKE AANWIJZINGEN en WAARSCHUWINGEN!**



**WAARSCHUWING:** Een WAARSCHUWING vestigt uw aandacht op de mogelijkheid van ernstig of dodelijk letsel als u de instructies niet opvolgt.



**VOORZICHTIG:** De aanwijzing VOORZICHTIG vestigt uw aandacht op de mogelijkheid van beschadiging of onherstelbare beschadiging van de apparatuur als u de betreffende instructies niet opvolgt.



**WAARSCHUWING:** Door niet alle instructies te lezen, volledig te begrijpen en op te volgen, riskeert u ernstig persoonlijk letsel, beschadiging van de apparatuur en het vervallen van de fabrieksgarantie. Degene die het product installeert is ervoor verantwoordelijk dat alle onderdelen aan

de hand van de meegeleverde handleiding op de juiste wijze worden samengebouwd en gemonteerd.



### **IMPORTANT AVERTISSEMENTS et PRÉCAUTIONS!**



**AVERTISSEMENT:** Un AVERTISSEMENT vous met en garde contre les possibilités de blessures graves ou de danger de mort si vous ne suivez pas les instructions.



**PRÉCAUTION:** Une PRÉCAUTION vous met en garde contre les possibilités d'endommagements et de destruction de l'équipement si vous ne suivez pas les instructions correspondantes.



**AVERTISSEMENT:** Le manque de la lecture, de la compréhension et du respect total de toutes les instructions, peut entraîner des blessures corporelles graves, endommager l'équipement ou annuler la garantie d'usine. Il incombe à l'installateur de s'assurer que tous les composants sont correctement assemblés et installés à l'aide des instructions fournies.

### **NOTE:**

- It is the installer's responsibility to ensure that the enclosure is bonded to the ground in the switch box, in accordance with the National Electric Code, ANSI/NFPA 70 or Canadian Electrical Code, CSA C22.1. A green grounding screw is provided in the enclosure for the purpose, if required.
- Spacings - To ensure safe operation of the equipment installed in the enclosure, per National Electric Code ANSI/NFPA 70, a minimum separation between power cords and signal or communication cables may be required.
- This Cabinet System is for use with Listed ITE or Audio/Video equipment only.

**DIMENSIONS**

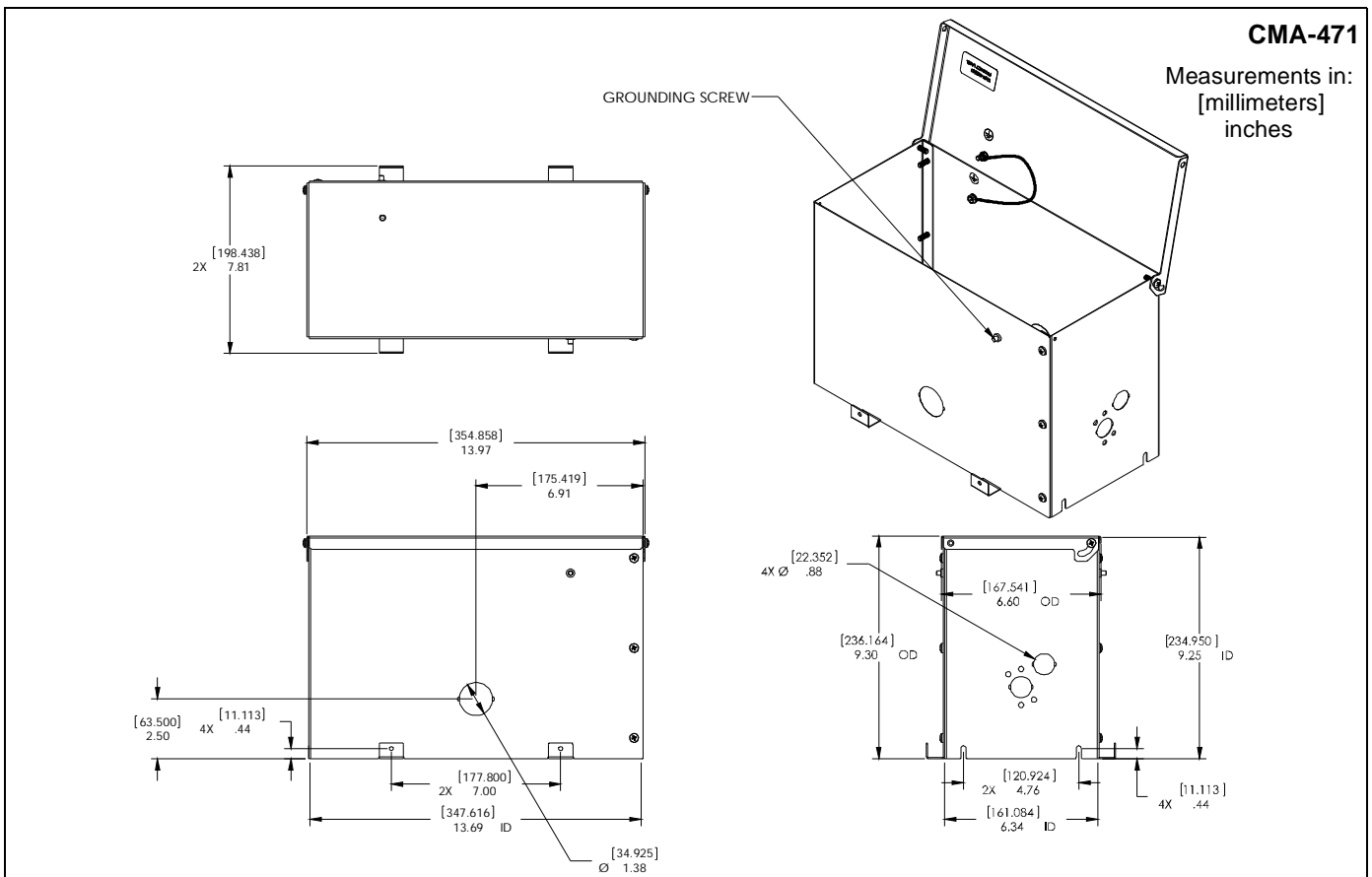
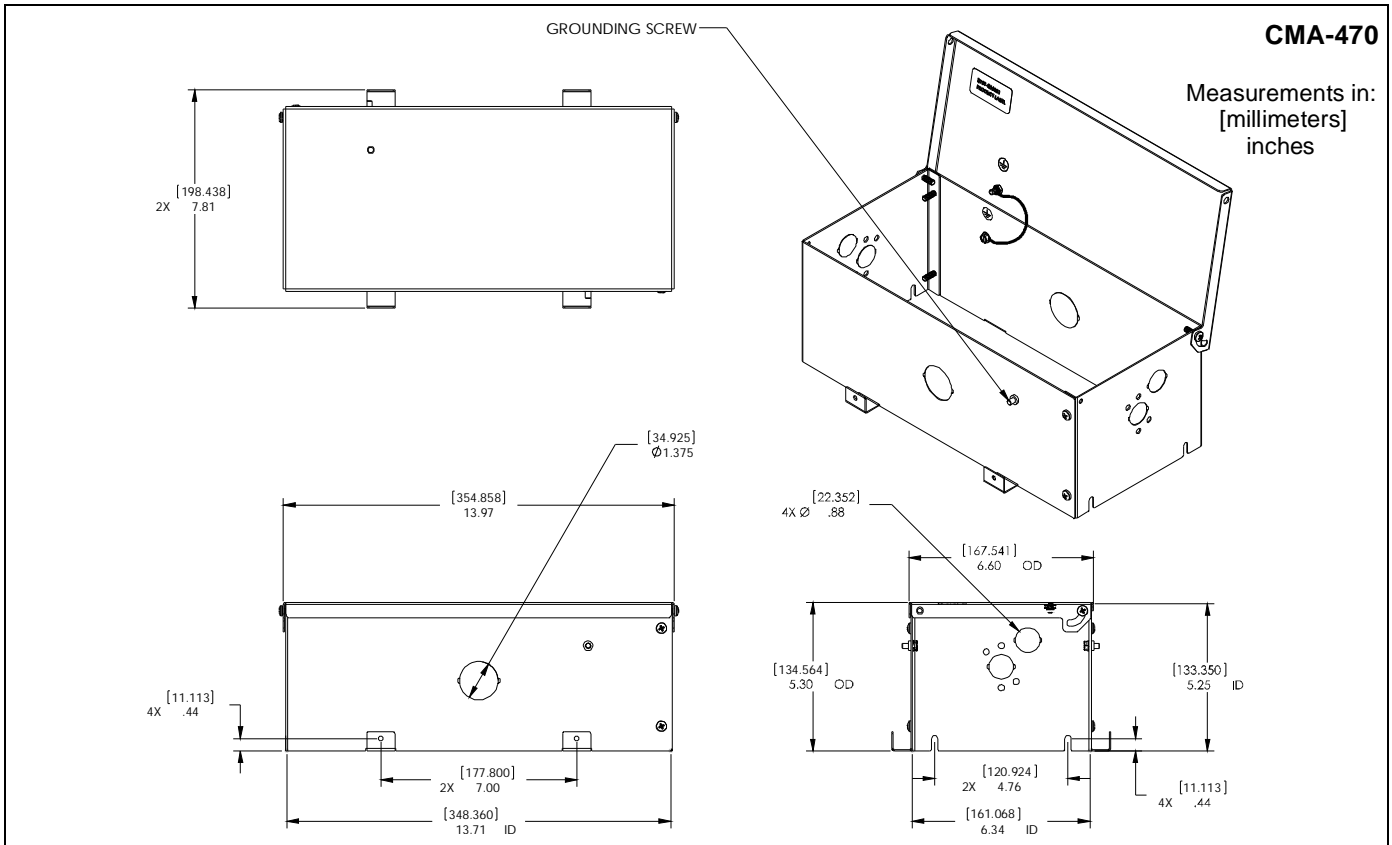

**LEGEND**

	<b>Tighten Fastener</b>
	Apretar elemento de fijación
	Befestigungsteil festziehen
	Apertar fixador
	Serrare il fissaggio
	Bevestiging vastdraaien
	Serrez les fixations

	<b>Phillips Screwdriver</b>
	Destornillador Phillips
	Kreuzschlitzschraubendreher
	Chave de fendas Phillips
	Cacciavite a stella
	Kruiskopschroevendraaier
	Tournevis à pointe cruciforme

	<b>Loosen Fastener</b>
	Aflojar elemento de fijación
	Befestigungsteil lösen
	Desapertar fixador
	Allentare il fissaggio
	Bevestiging losdraaien
	Desserrez les fixations

**TOOLS REQUIRED FOR INSTALLATION**

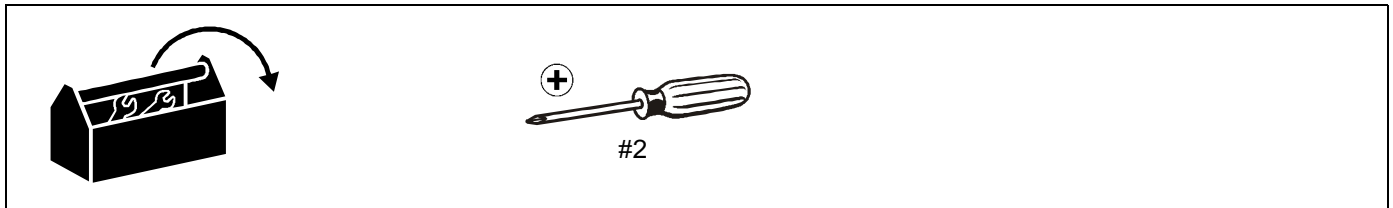

**PARTS**

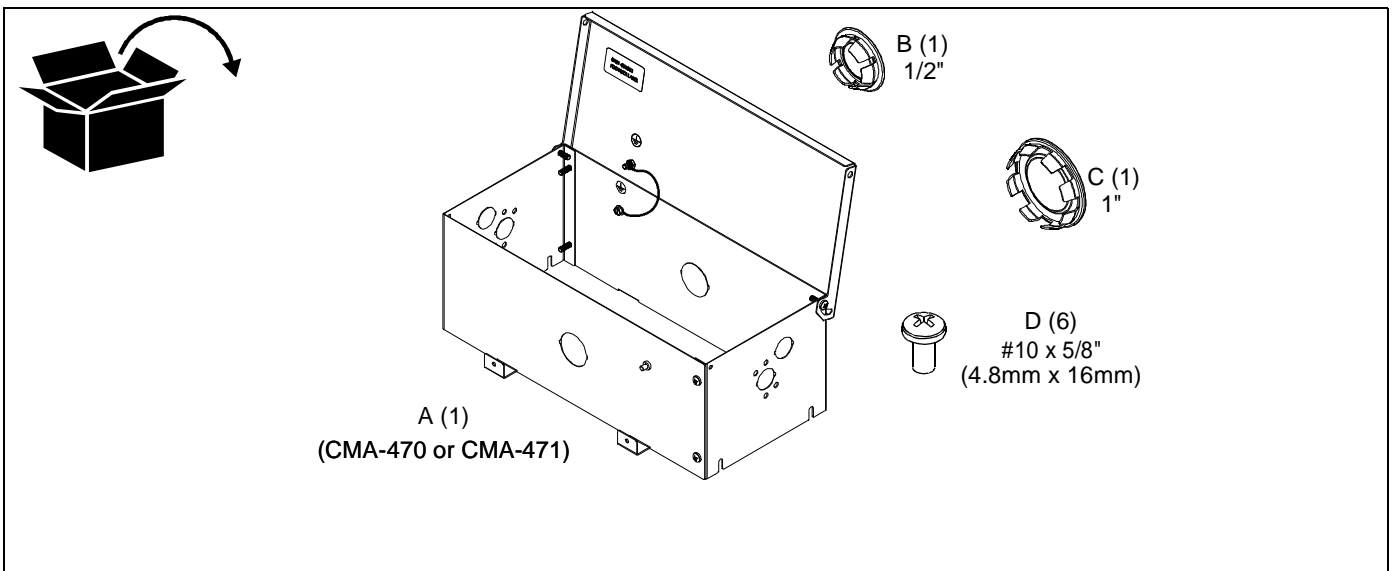

## INSTALLATION



**WARNING:** IMPROPER INSTALLATION CAN LEAD TO MOUNT FALLING CAUSING SEVERE PERSONAL INJURY OR DAMAGE TO EQUIPMENT! The equipment must be assembled and installed by qualified service personnel.

1. Install CMA-440/-450/-455 or CMS-440 (accessory not included). See installation instructions included with the accessory.

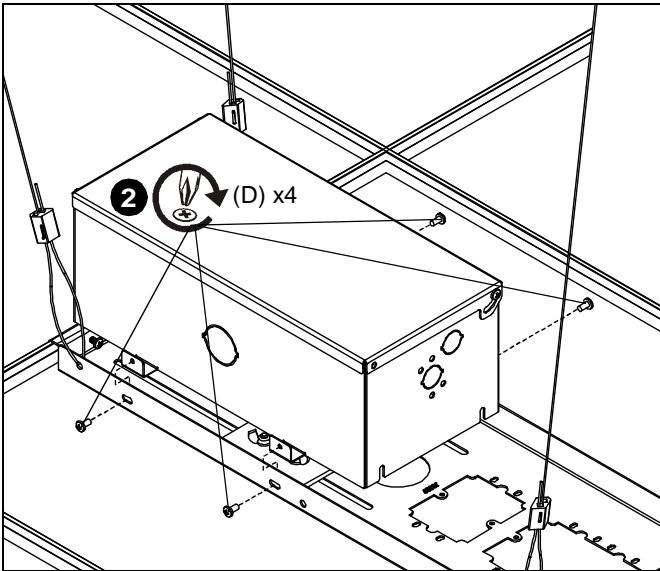
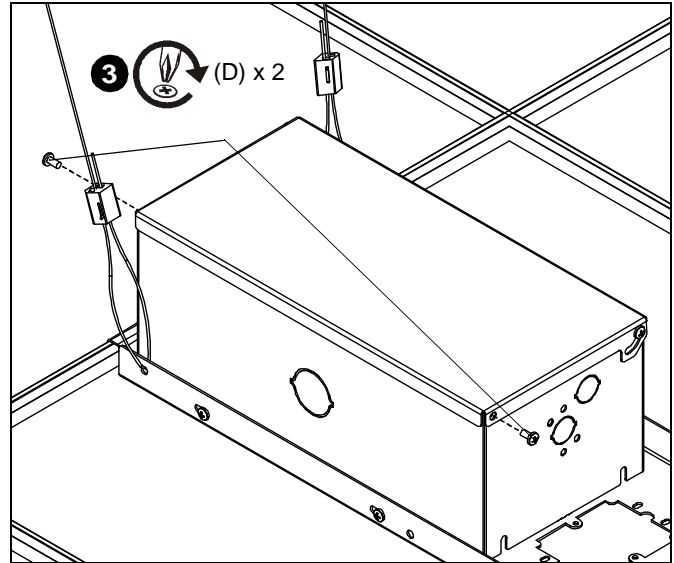

**Figure 1**

2. Install box (A) with four screws (D) (See Figure 1). Tighten securely.

**NOTE:** Box shown installed to CMS-440. CMA accessories similar.

3. Secure lid to box (A) with two screws (D) (See Figure 2). Tighten securely.



**Figure 2**

4. Connect ground wire to grounding screw. (See Figure 3)

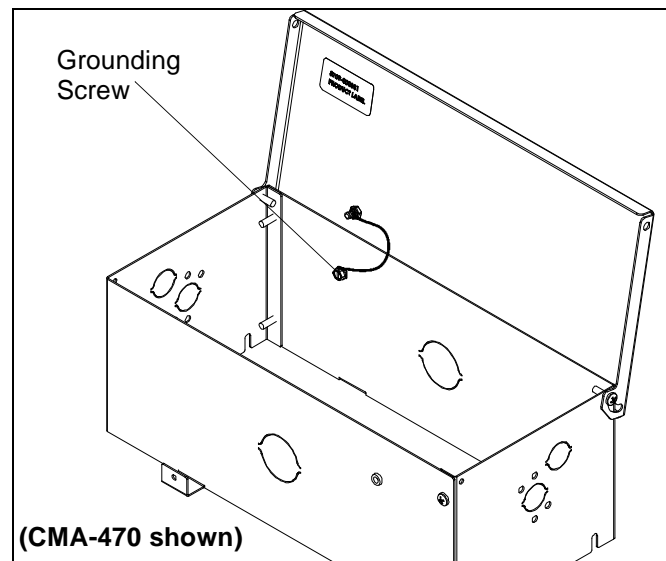

**Figure 3**

**NOTE:** Knockouts are provided for ease of installation. Any open knockout needs to be plugged, using parts (B) or (C). Additional 1/2" (B) or 1" (C) plugs may be purchased at a local store, if needed.





Our Mounts. **Your Vision.**

Chief, a products division of  
Milestone AV Technologies

8800-002677 Rev00  
©2014 Milestone AV Technologies  
[www.chiefmfg.com](http://www.chiefmfg.com)  
11/14

<b>USA/International</b>	<b>A</b> 6436 City West Parkway, Eden Prairie, MN 55344 <b>P</b> 800.582.6480 / 952.225.6000 <b>F</b> 877.894.6918 / 952.894.6918
<b>Europe</b>	<b>A</b> Franklinstraat 14, 6003 DK Weert, Netherlands <b>P</b> +31 (0) 495 580 852 <b>F</b> +31 (0) 495 580 845
<b>Asia Pacific</b>	<b>A</b> Office No. 918 on 9/F, Shatin Galleria 18-24 Shan Mei Street Fotan, Shatin, Hong Kong <b>P</b> 852 2145 4099 <b>F</b> 852 2145 4477

