

---

# INSTALLATION INSTRUCTIONS

---

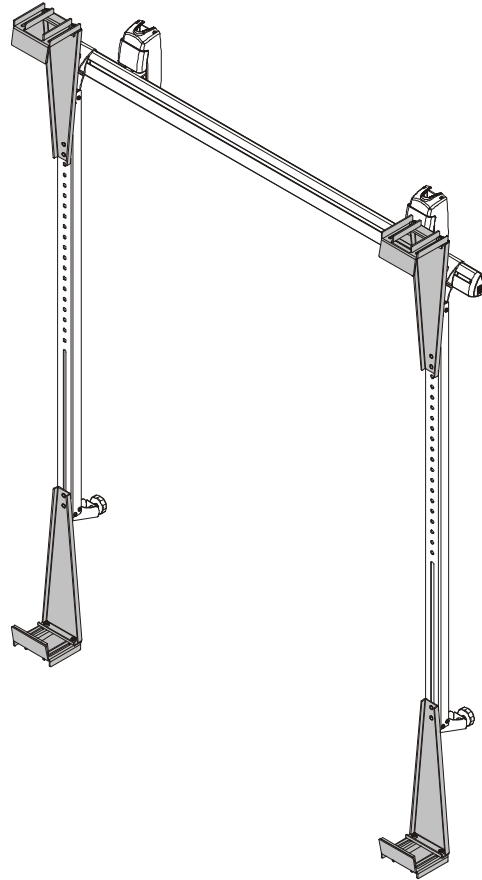

---

## Universal Interactive Board Adapter Kit

---

## DISCLAIMER

Milestone AV Technologies and its affiliated corporations and subsidiaries (collectively "Milestone"), intend to make this manual accurate and complete. However, Milestone makes no claim that the information contained herein covers all details, conditions or variations, nor does it provide for every possible contingency in connection with the installation or use of this product. The information contained in this document is subject to change without notice or obligation of any kind. Milestone makes no representation of warranty, expressed or implied, regarding the information contained herein. Milestone assumes no responsibility for accuracy, completeness or sufficiency of the information contained in this document.

Chief® is a registered trademark of Milestone AV Technologies. All rights reserved.



## IMPORTANT SAFETY INSTRUCTIONS



**WARNING:** A WARNING alerts you to the possibility of serious injury or death if you do not follow the instructions.



**CAUTION:** A CAUTION alerts you to the possibility of damage or destruction of equipment if you do not follow the corresponding instructions.



**WARNING:** Failure to read, thoroughly understand, and follow all instructions can result in serious personal injury, damage to equipment, or voiding of factory warranty! It is the installer's responsibility to make sure all components are properly assembled and installed using the instructions provided.



**WARNING:** Failure to provide adequate structural strength for this component can result in serious personal injury or damage to equipment! It is the installer's responsibility to make sure the structure to which this component is attached can support five times the combined weight of all equipment. Reinforce the structure as required before installing the component.



**WARNING:** Exceeding the weight capacity can result in serious personal injury or damage to equipment! It is the installer's responsibility to make sure the combined weight of all components attached to the WBAU does not exceed 125 lbs (56.7 kg).



**WARNING:** Use this mounting system only for its intended use as described in these instructions. Do not use attachments not recommended by the manufacturer.



**WARNING:** Never operate this mounting system if it is damaged. Return the mounting system to a service center for examination and repair.



**WARNING:** Do not use this product outdoors.

**IMPORTANT ! :** The WBAU accessory is used with the UL Listed WBM2 and is compatible with boards 26.69" (minimum) - 59.22" (maximum) tall, and 0.51" (minimum) - 3.14" (maximum) deep.

**--SAVE THESE INSTRUCTIONS--**

**DIMENSIONS**

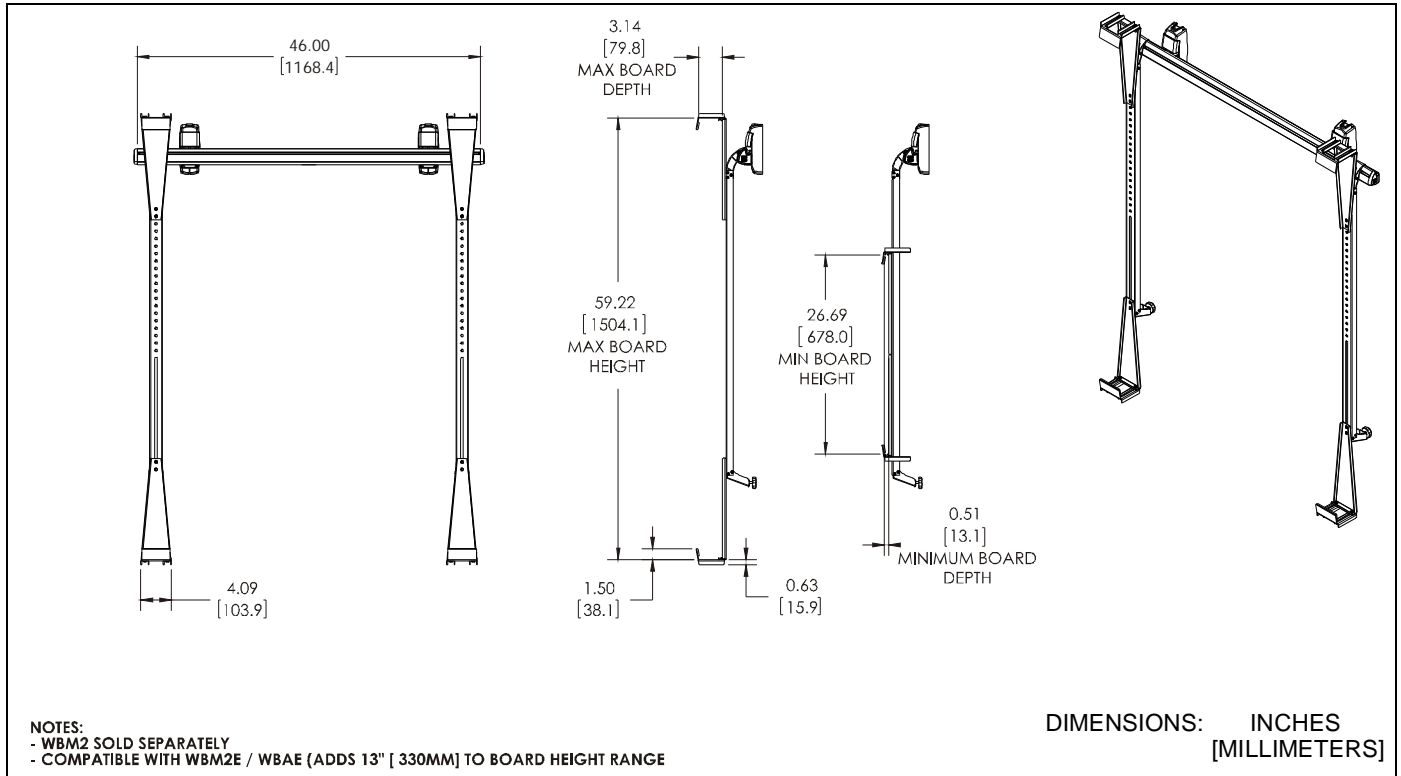

**LEGEND**

	<b>Tighten Fastener</b>		<b>Open-Ended Wrench</b>
	Apretar elemento de fijación		Llave de boca
	Befestigungsteil festziehen		Gabelschlüssel
	Apertar fixador		Chave de bocas
	Serrare il fissaggio		Chiave a punta aperte
	Bevestiging vastdraaien		Steeksleutel
Serrez les fixations	Clé à fourche		<b>Hex-Head Wrench</b>
<b>Loosen Fastener</b>	Llave de cabeza hexagonal		
Aflojar elemento de fijación	Sechskantschlüssel		
Befestigungsteil lösen	Chave de cabeça sextavada		
Desapertar fixador	Chiave esagonale		
Allentare il fissaggio	Zeskantsleutel		
Bevestiging losdraaien	Clé à tête hexagonale		<b>Socket Wrench</b>
Desserrez les fixations	Llave de cubo		
	Steckschlüssel		
	Chave de caixa		
	Chiave a brugola		
	Dopsleutel		
	Clé à douilles		

### TOOLS REQUIRED FOR INSTALLATION

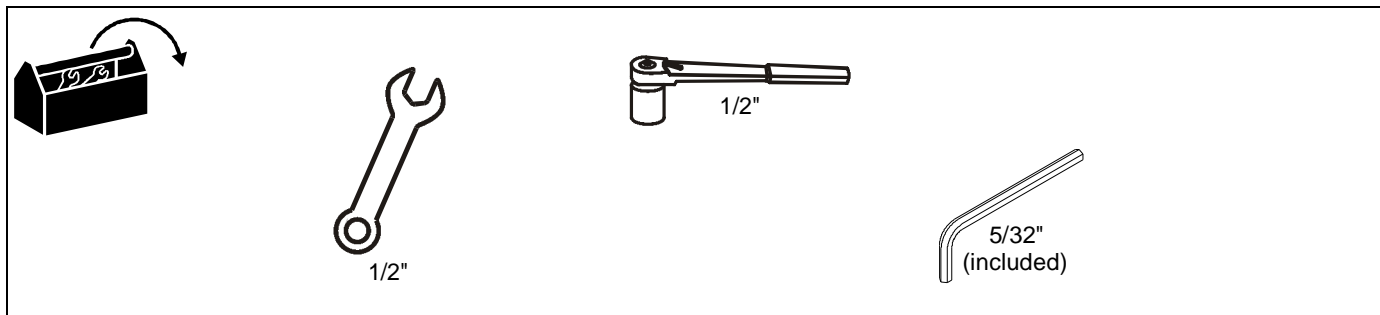

### PARTS

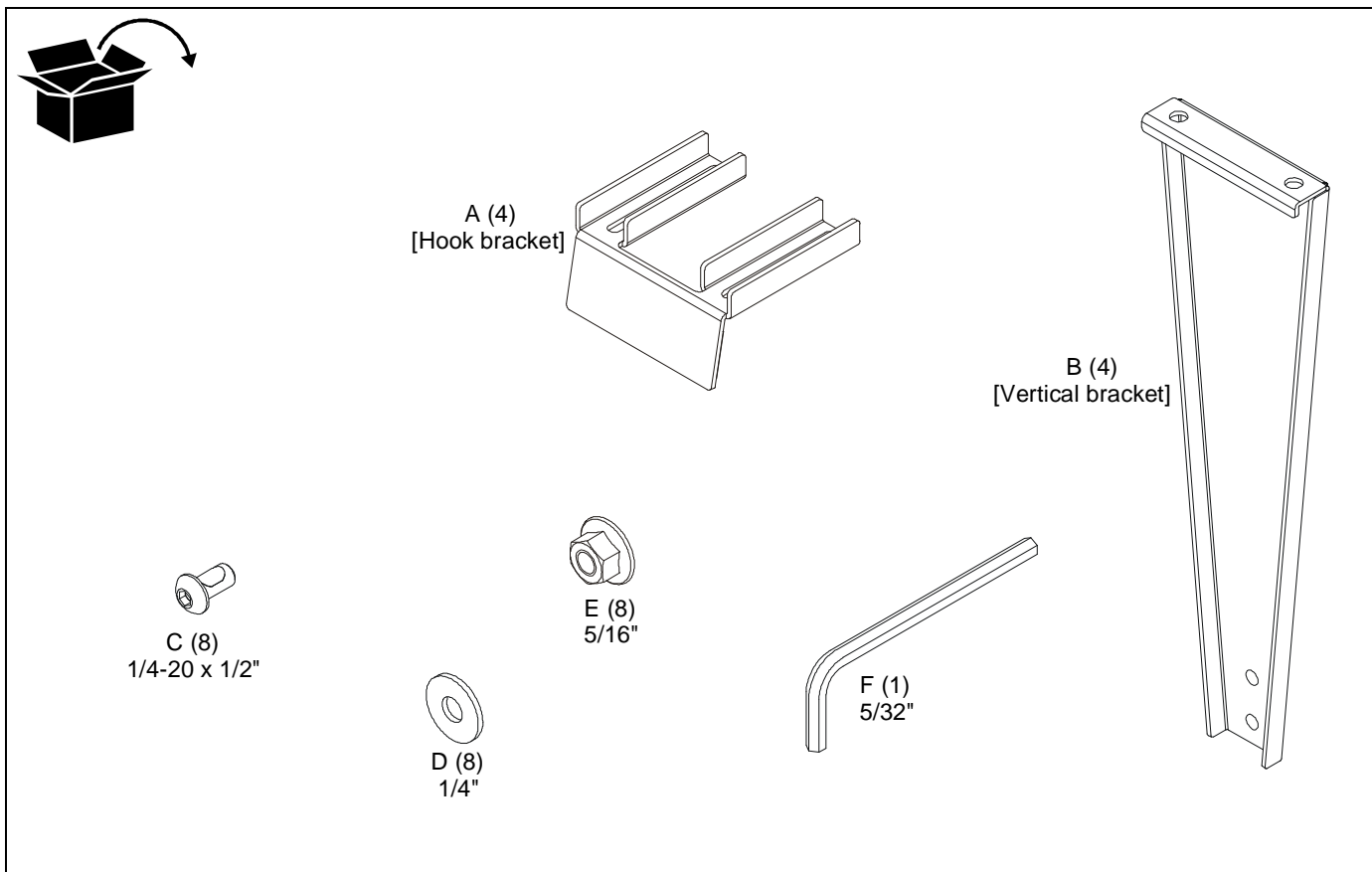

## ASSEMBLY AND INSTALLATION

### Assembly

1. Assemble one hook bracket (A) to one vertical bracket (B) using two 1/4-20 x 1/2" button head cap screws (C) and two 1/4" flat washers (D). (See Figure 1)
2. Repeat for remaining three bracket assemblies.

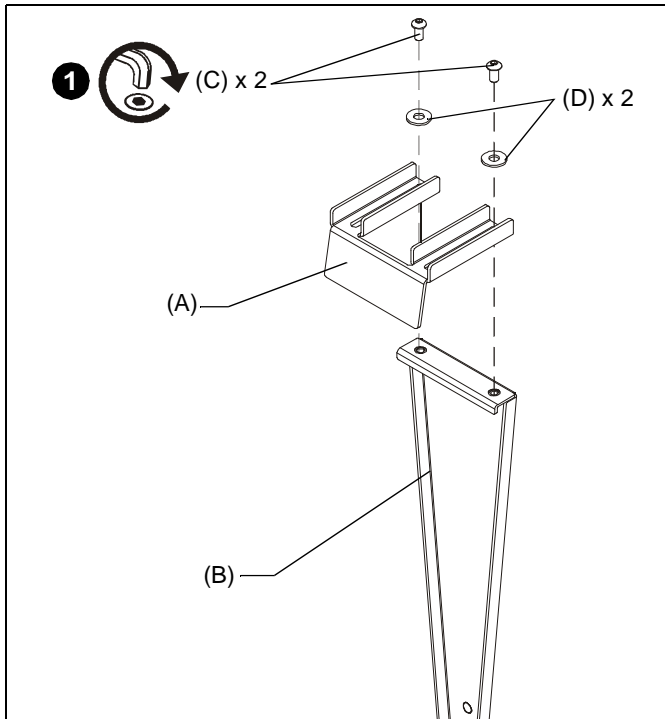

Figure 1

### INSTALLATION

**IMPORTANT !** : These installation instructions assume that a UL Listed WBM2 interactive whiteboard mount has been properly installed and is in place.

1. Remove the WBM2 uprights from the WBM2 mount following instructions included with the WBM2.
2. Using two 5/16" hex nuts with flange (E) install one bracket assembly to the lower end of one WBM2 upright. (See Figure 2)
3. Repeat Step 2 on the other WBM2 upright.

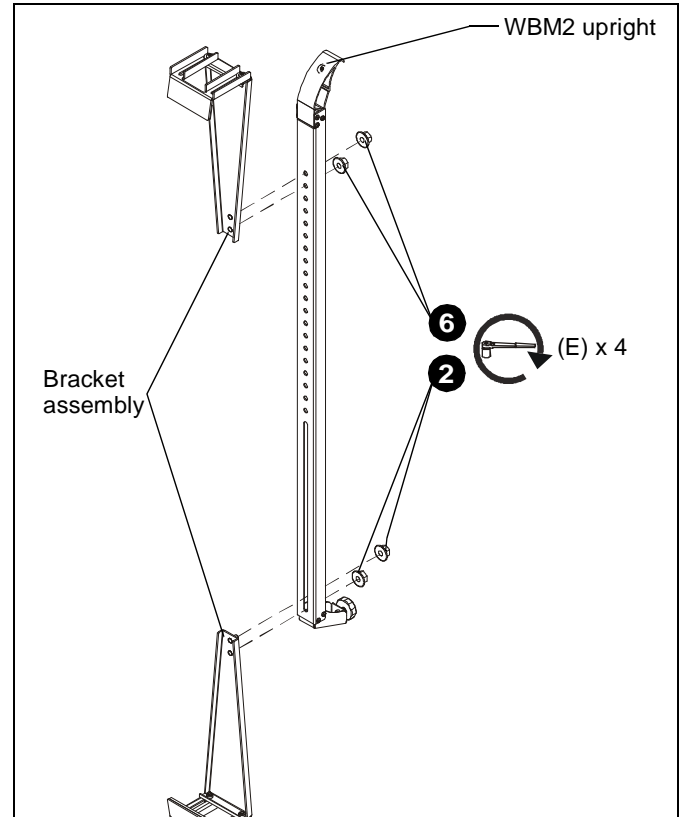

Figure 2

4. Place interactive board onto the two installed bracket assemblies.
5. Determine where upper bracket assemblies should attach to WBM2.
6. Using two 5/16" hex nuts with flange (E) install one bracket assembly to upper part of one WBM2 upright. (See Figure 2)
7. Repeat Step 6 on the other WBM2 upright.

**IMPORTANT !** : The WBAU accessory is compatible with boards 26.69" (minimum) - 59.22" (maximum) tall, and 0.51" (minimum) - 3.14" (maximum) deep. (See Figure 3)

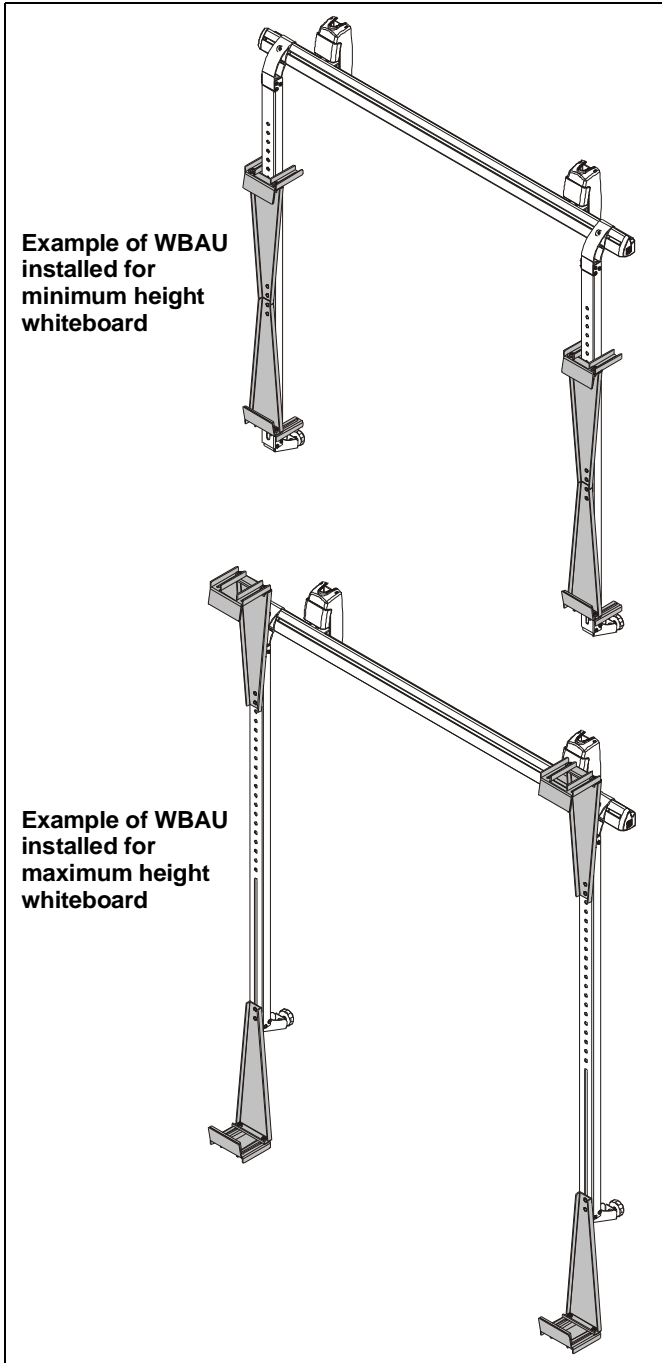

Figure 3

8. Loosen button head cap screws (C) on bracket assemblies using 5/32" hex head wrench (F) to allow adjustment to fit whiteboard depth. (See Figure 4)
9. Adjust bracket assemblies so they are pressed against whiteboard.
10. Tighten button head cap screws (C) on bracket assemblies. (See Figure 4)

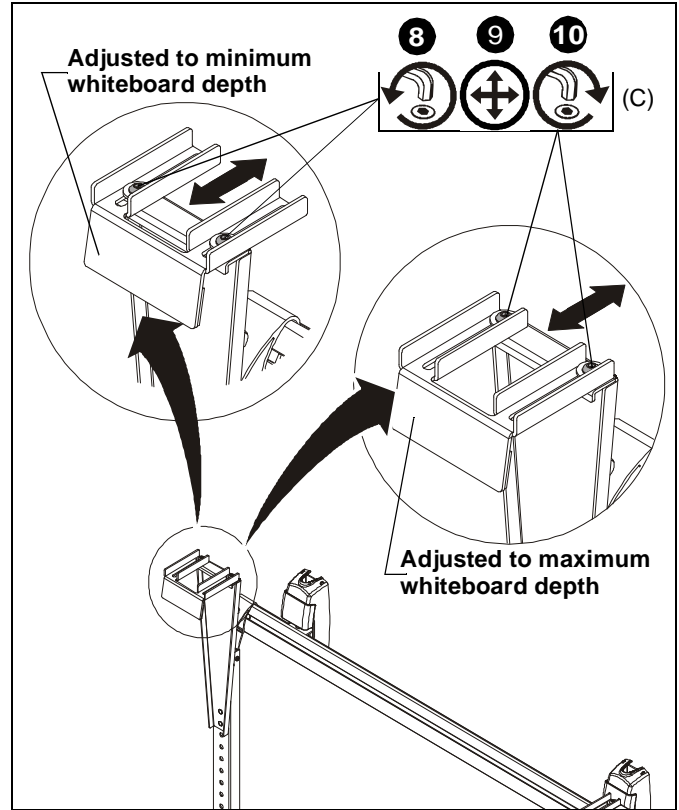

Figure 4

11. Reinstall WBM2 uprights with attached whiteboard to WBM2 mount, following instructions included with the WBM2.





Our Mounts. **Your Vision.**

Chief Manufacturing, a products division  
of Milestone AV Technologies

8800-002235 Rev01  
©2013 Milestone AV Technologies, a  
Duchossois Group Company  
[www.chiefmfg.com](http://www.chiefmfg.com)  
01/13

<b>USA/International</b>	<b>A</b> 6436 City West Parkway, Eden Prairie, MN 55344 <b>P</b> 800.582.6480 / 952.225.6000 <b>F</b> 877.894.6918 / 952.894.6918
<b>Europe</b>	<b>A</b> Franklinstraat 14, 6003 DK Weert, Netherlands <b>P</b> +31 (0) 495 580 852 <b>F</b> +31 (0) 495 580 845
<b>Asia Pacific</b>	<b>A</b> Office No. 1 on 12/F, Shatin Galleria 18-24 Shan Mei Street Fotan, Shatin, Hong Kong <b>P</b> 852 2145 4099 <b>F</b> 852 2145 4477

