

1 1/2" NPT THREADS  
5/16 - 18 UNC THREADS

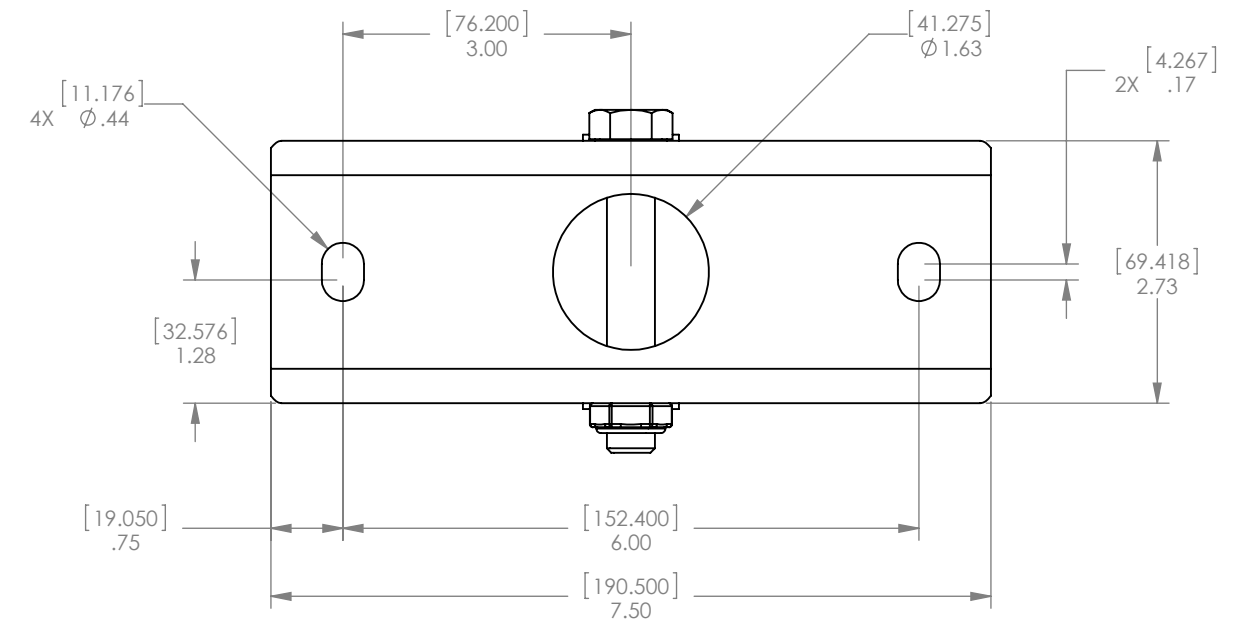

205 Westwood Ave, Long Branch, NJ 07740  
 Phone: 866-94 BOARDS (26273) / (732)-222-1511  
 Fax: (732)-222-7088 | E-mail: sales@touchboards.com

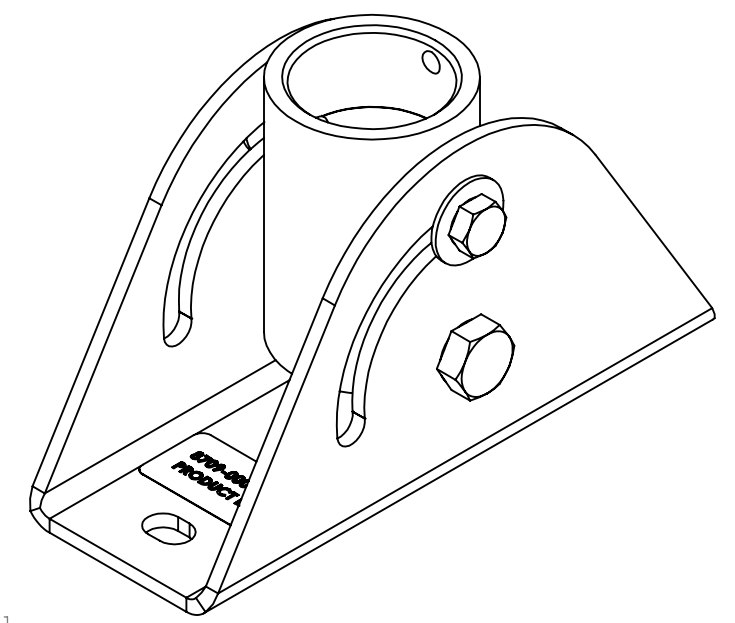
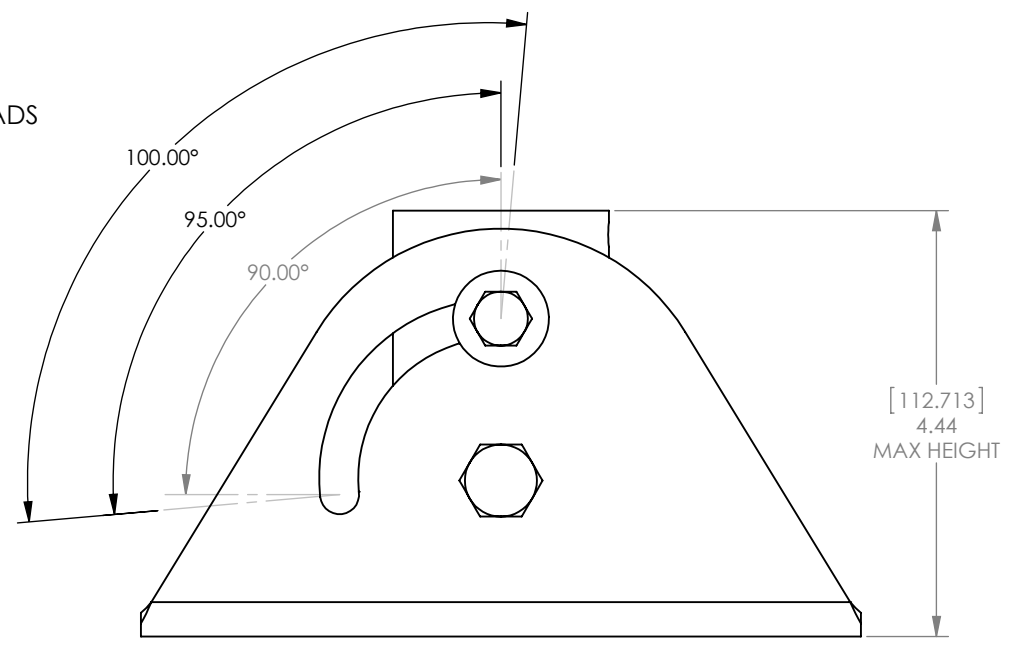
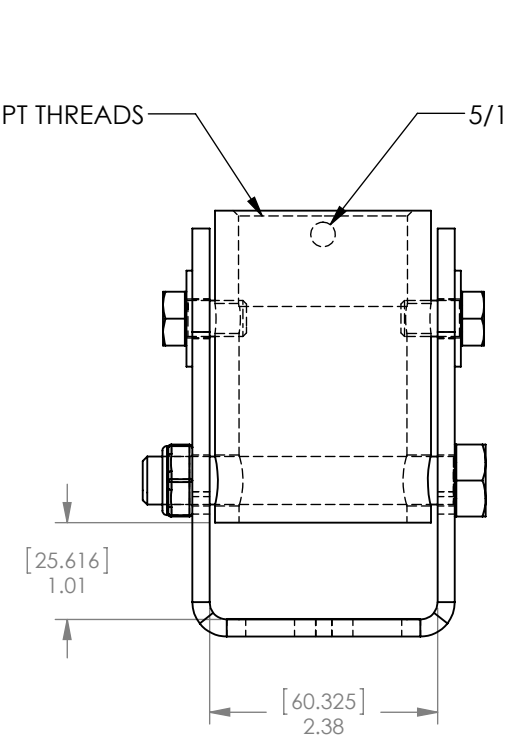

CHIEF MANUFACTURING INC.  
 MOUNT ORDER NUMBER IS CMA395  
 PHONE: 1-800-582-6480

THE INFORMATION AND DESIGNS CONTAINED IN THIS DRAWING ARE CONFIDENTIAL AND THE PROPRIETARY PROPERTY OF MILESTONE AV TECHNOLOGIES. NEITHER THIS DESIGN NOR ANY INFORMATION CONTAINED IN THIS DRAWING MAY BE REPRODUCED OR DISCLOSED TO OTHERS WITHOUT THE EXPRESS WRITTEN CONSENT OF MILESTONE AV TECHNOLOGIES.

MAX. WEIGHT 500 LBS.



TITLE  
 CUSTOMER PRINT,  
 ASSEMBLY, ANGLED CEILING  
 ADAPTER CMA395

SIZE | DWG. NO.  
 B BRACKET ORDER # CMA395