

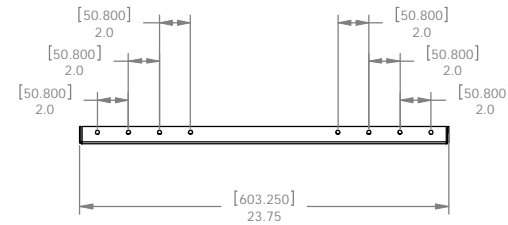

205 Westwood Ave, Long Branch, NJ 07740
 Phone: 866-94 BOARDS (26273) / (732)-222-1511
 Fax: (732)-222-7088 | E-mail: sales@touchboards.com

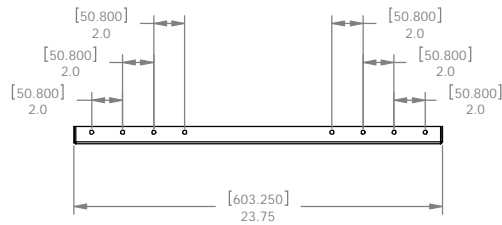
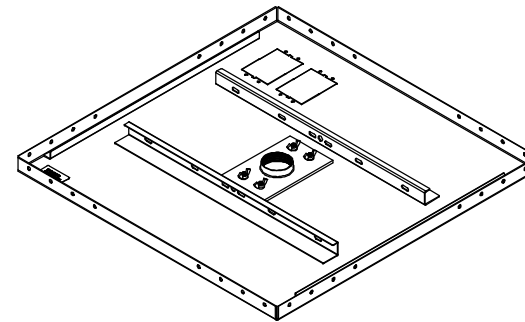
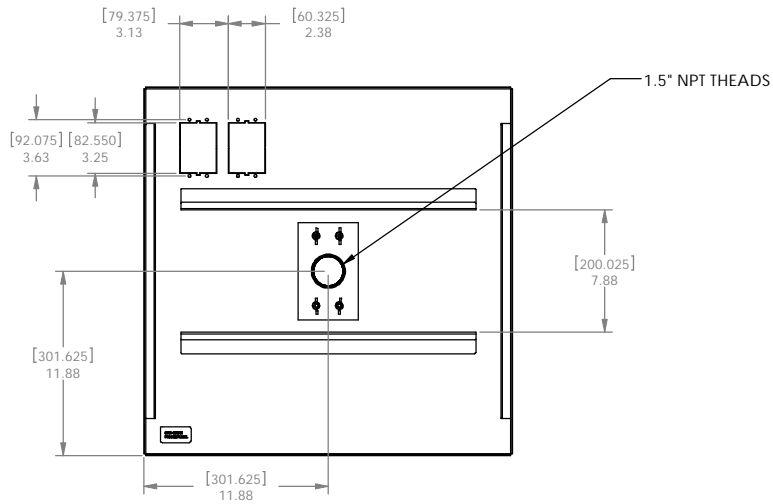

CHIEF MANUFACTURING INC.
 MOUNT ORDER NUMBER IS CMA-455
 PHONE: 1-800-582-6480

THE INFORMATION AND DESIGNS CONTAINED IN THIS DRAWING ARE CONFIDENTIAL AND THE PROPRIETARY PROPERTY OF CHIEF MFG., INC. NEITHER THIS DESIGN NOR ANY INFORMATION CONTAINED IN THIS DRAWING MAY BE REPRODUCED OR DISCLOSED TO OTHERS WITHOUT THE EXPRESS WRITTEN CONSENT OF CHIEF MFG., INC.

CHIEF 8401 EAGLE CREEK PKY
 SAVAGE, MN 55378
 PHONE: 952-894-6260
 FAX: 877-894-6918

TITLE
 CUSTOMER PRINT
 ASSEMBLY, CEILING PLATE,
 24" X 24" CMA-455

SIZE DWG. NO.
 B CMA-455

CMA-455

D

C

B

A

1 2 3 4 5 6 7 8

1 2 3 4 5 6 7 8