

# INSTALLATION INSTRUCTIONS

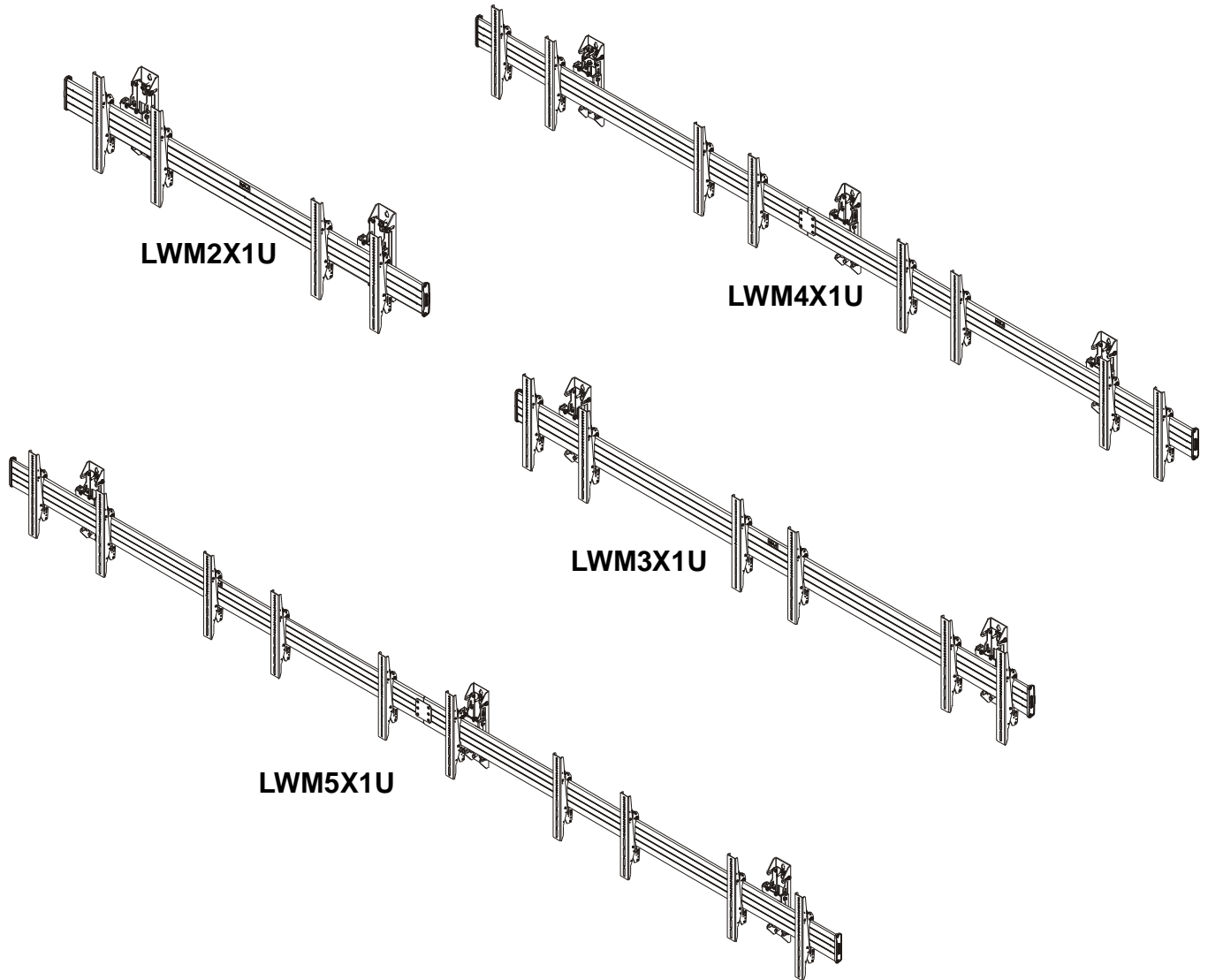

## Wall-Mounted Menu Boards

**Touchboards**

205 Westwood Ave, Long Branch, NJ 07740  
Phone: 866-94 BOARDS (26273) / (732)-222-1511  
Fax: (732)-222-7088 | E-mail: [sales@touchboards.com](mailto:sales@touchboards.com)

**DISCLAIMER**

Milestone AV Technologies and its affiliated corporations and subsidiaries (collectively “Milestone”), intend to make this manual accurate and complete. However, Milestone makes no claim that the information contained herein covers all details, conditions or variations, nor does it provide for every possible contingency in connection with the installation or use of this product. The information contained in this document is subject to change without notice or obligation of any kind. Milestone makes no representation of warranty, expressed or implied, regarding the information contained herein. Milestone assumes no responsibility for accuracy, completeness or sufficiency of the information contained in this document.

Chief® is a registered trademark of Milestone AV Technologies. All rights reserved.

 **IMPORTANT SAFETY INSTRUCTIONS**

 **WARNING:** A WARNING alerts you to the possibility of serious injury or death if you do not follow the instructions.

 **CAUTION:** A CAUTION alerts you to the possibility of damage or destruction of equipment if you do not follow the corresponding instructions.

 **WARNING:** Failure to read, thoroughly understand, and follow all instructions can result in serious personal injury, damage to equipment, or voiding of factory warranty! It is the installer’s responsibility to make sure all components are properly assembled and installed using the instructions provided.

 **WARNING:** Failure to provide adequate structural strength for this component can result in serious personal injury or damage to equipment! It is the installer’s responsibility to make sure the structure to which this component is attached can support five times the combined weight of all equipment. Reinforce the structure as required before installing the component.

 **WARNING:** Exceeding the weight capacity can result in serious personal injury or damage to equipment! It is the installer’s responsibility to make sure the combined weight of all components located within the mounting system of the LWM Series mounts does not exceed maximum weights noted in table below.

MODEL	Max Weight Allowed for EACH Display	Max Weight Capacity of Mounting System
LWM2X1U	125 lbs (56.7 kg)	250 lbs (113.4 kg)
LWM3X1U	125 lbs (56.7 kg)	375 lbs (170.1 kg)
LWM4X1U	125 lbs (56.7 kg)	500 lbs (226.8 kg)
LWM5X1U	125 lbs (56.7 kg)	625 lbs (283.5 kg)

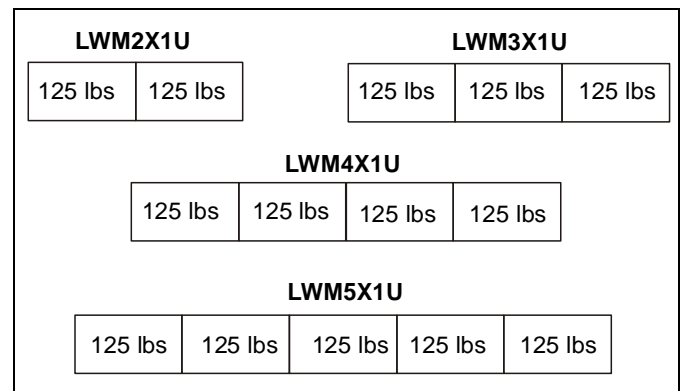

 **WARNING:** Use this mounting system only for its intended use as described in these instructions. Do not use attachments not recommended by the manufacturer.

 **WARNING:** Never operate this mounting system if it is damaged. Return the mounting system to a service center for examination and repair.

 **WARNING:** Do not use this product outdoors.

**IMPORTANT ! :** The LWM Series mounts are designed to be mounted to a 2" x 4" wood studs (16" on center) wall; or a bare 8" concrete wall. The LWM Series mounts are designed to accept displays in the 40-55" (1016-1397mm) size.

**--SAVE THESE INSTRUCTIONS--**

**LEGEND**

	<p><b>Tighten Fastener</b></p> <p>Apretar elemento de fijación</p> <p>Befestigungsteil festziehen</p> <p>Apertar fixador</p> <p>Serrare il fissaggio</p> <p>Bevestiging vastdraaien</p> <p>Serrez les fixations</p>		<p><b>Pencil Mark</b></p> <p>Marcar con lápiz</p> <p>Stiftmarkierung</p> <p>Marcar com lápis</p> <p>Segno a matita</p> <p>Potloodmerkten</p> <p>Marquage au crayon</p>
	<p><b>Loosen Fastener</b></p> <p>Aflojar elemento de fijación</p> <p>Befestigungsteil lösen</p> <p>Desapertar fixador</p> <p>Allentare il fissaggio</p> <p>Bevestiging losdraaien</p> <p>Desserrez les fixations</p>		<p><b>Drill Hole</b></p> <p>Perforar</p> <p>Bohrloch</p> <p>Fazer furo</p> <p>Praticare un foro</p> <p>Gat boren</p> <p>Percez un trou</p>
	<p><b>Phillips Screwdriver</b></p> <p>Destornillador Phillips</p> <p>Kreuzschlitzschraubendreher</p> <p>Chave de fendas Phillips</p> <p>Cacciavite a stella</p> <p>Kruiskopschroevendraaier</p> <p>Tournevis à pointe cruciforme</p>		<p><b>Adjust</b></p> <p>Ajustar</p> <p>Einstellen</p> <p>Ajustar</p> <p>Regolare</p> <p>Afstellen</p> <p>Ajuster</p>
	<p><b>Open-Ended Wrench</b></p> <p>Llave de boca</p> <p>Gabelschlüssel</p> <p>Chave de bocas</p> <p>Chiave a punte aperte</p> <p>Steeksleutel</p> <p>Clé à fourche</p>		<p><b>Remove</b></p> <p>Quitar</p> <p>Entfernen</p> <p>Remover</p> <p>Rimuovere</p> <p>Verwijderen</p> <p>Retirez</p>
	<p><b>By Hand</b></p> <p>A mano</p> <p>Von Hand</p> <p>Com a mão</p> <p>A mano</p> <p>Met de hand</p> <p>À la main</p>		<p><b>Optional</b></p> <p>Opcional</p> <p>Optional</p> <p>Opcional</p> <p>Opzionale</p> <p>Optie</p> <p>En option</p>
	<p><b>Hex-Head Wrench</b></p> <p>Llave de cabeza hexagonal</p> <p>Sechskantschlüssel</p> <p>Chave de cabeça sextavada</p> <p>Chiave esagonale</p> <p>Zeskantsleutel</p> <p>Clé à tête hexagonale</p>		<p><b>Security Wrench</b></p> <p>Llave de seguridad</p> <p>Sicherheitsschlüssel</p> <p>Chave de segurança</p> <p>Chiave di sicurezza</p> <p>Veiligheidsleutel</p> <p>Clé de sécurité</p>

**TOOLS REQUIRED FOR INSTALLATION**

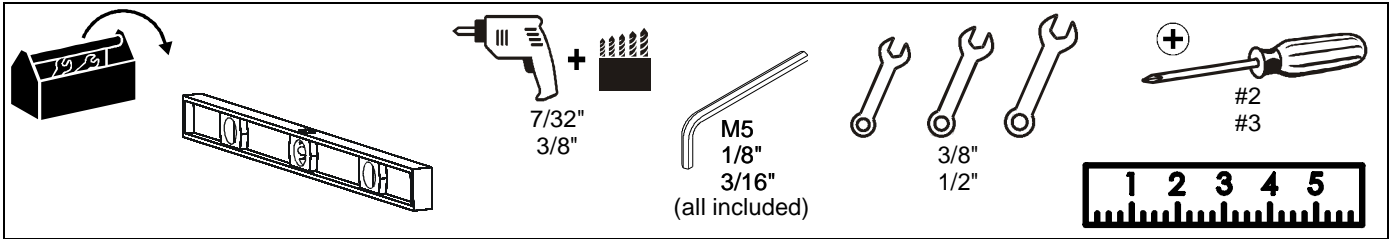

**PARTS**

[Quantities listed in order for models: LWM2X1/LWM3X1/LWM4X1/LWM5X1]

**DISPLAY ATTACH HARDWARE BAG (2/3/4/5)**  
(Qty listed per hardware bag)

A (8) M4x16mm  
B (6) M4x20mm  
C (6) M4x25mm  
D (6) M5x16mm  
E (6) M5x20mm  
F (6) M5x25mm  
G (6) M6x16mm  
H (6) M6x25mm  
I (6) M8x20mm  
J (6) M8x30mm  
K (4) M8x50mm  
L (8) .75x.323x.25"  
M (8) .75x.344x.5"  
N (8) [Univ. washer]  
P (1) M5 (In section marked "N")

Q (1-72"/1-108"/1-84"+1-72"/2-96")  
[Horizontal mounting rail]  
(Example shown: 72" mounting rail for LWM2X1)

R (4/6/8/10) [Interface bracket]

**END CAP KIT (1/1/1/1)**  
S (2) [End cap]  
T (4) 1/4-20 x 1/2"

**INTERFACE HARDWARE (2/3/4/5)**  
(Qty listed per bag)

T (1) 1/8"  
U (2) 10-24  
V (2) 10-24 x 5/8"  
W (2) 10-24 x 2-1/4"

**WALL MOUNT HARDWARE (2/2/3/3)**  
(Qty listed per hardware bag)

X (4) 5/16 x 1/2"  
Y (2) 5/16 x 2-3/4"  
Z (2) [Anchor]  
AA (2) 5/16"

BB (2/2/3/3) [Height adjust plate]  
CC (2/2/2/2) [Outside wall upright]  
DD (0/0/1/1) [Center wall upright]

**MENU BOARD CONNECTOR KIT (0/0/1/1)**  
(Qty listed per hardware bag)

EE (1) [Connect bracket]  
FF (8) 5/16"  
GG (1) [Connector plate]  
HH (8) 5/16 x 5/8"  
JJ (6) 10-24 x 1-1/2"  
KK (8) [Friction washer]  
LL (1) 1/8"  
MM (1) 3/16"  
NN (2) [Tie bar]

**WALL ATTACHMENT INFORMATION**

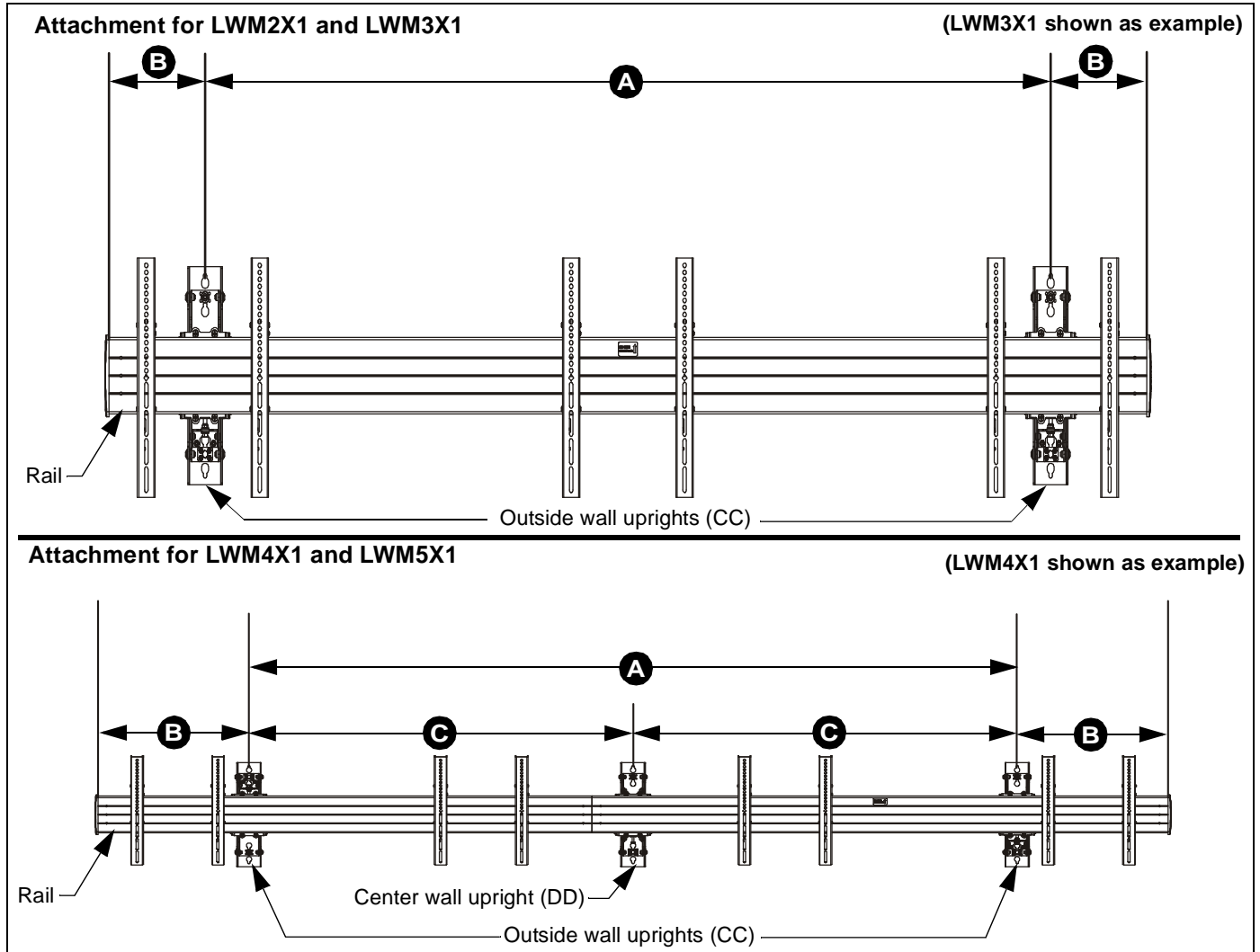

**Figure 1**

**Table 1: Wall Upright Specifications**

Model	A (Outside wall upright spacing)	B (End of rail to wall upright)	C (Wall upright spacing from outside to inside)
LWM2X1	48" - 64" (1219 - 1626mm)	"B" dimensions to be as close to equal as possible. <b>Not to exceed 12" (305mm).</b>	N/A
LWM3X1	64" - 88" (1626 - 2235mm)	"B" dimensions to be as close to equal as possible. <b>Not to exceed 22" (559mm).</b>	N/A
LWM4X1	96" - 128" (2438 - 3251mm)	"B" dimensions to be as close to equal as possible. <b>Not to exceed 30" (762mm).</b>	Center wall upright is to be centered as much as possible so that "C" dimensions are as close to equal as possible
LWM5X1	128" - 160" (3251 - 4064mm)	"B" dimensions to be as close to equal as possible. <b>Not to exceed 32" (813mm).</b>	Center wall upright is to be centered as much as possible so that "C" dimensions are as close to equal as possible

**IMPORTANT ! : DO NOT** locate any of the wall uprights (CC or DD) directly behind any of the display interface brackets (R).

## INSTALLATION

**IMPORTANT !** : Refer to **Dimensions** section at end of instructions to find specific LWM wall-mounted menu board dimension requirements **BEFORE** proceeding with installation.

**NOTE:** The outside wall uprights (CC) ship assembled to allow height adjustment from the bottom. The uprights may be changed to allow height adjustment from above the menu boards. See following instructions for changing the wall uprights.

If leaving wall uprights with height adjustment at the bottom, proceed to **ATTACH WALL UPRIGHTS** section.

### Adjusting Wall Uprights

If the installation requires height adjustment from **above** the menu boards, adjust the wall uprights (CC) **BEFORE** attaching uprights to the wall.

**IMPORTANT !** : Keep all hardware that is removed during this adjustment process.

1. Remove flanged nut and washer from top of wall upright. (CC) (See Figure 2)
2. Remove hex head screw from bottom of wall upright.

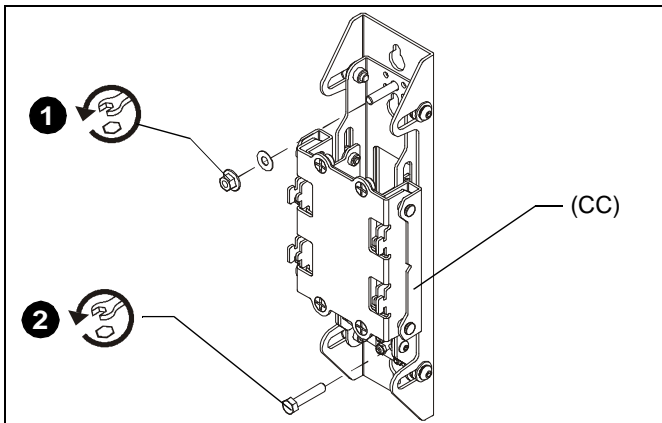

Figure 2

3. Remove one button head screw, spring washer and flat washer from four locations on side of wall upright. (See Figure 3)

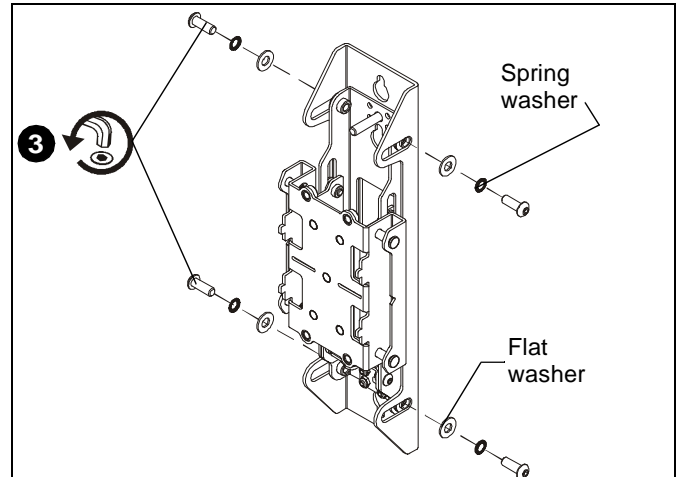

Figure 3

4. Remove wall upright assembly from outer bracket, while removing one shoulder washer and one steel washer from between outer bracket and wall upright assembly in four locations. (See Figure 4)

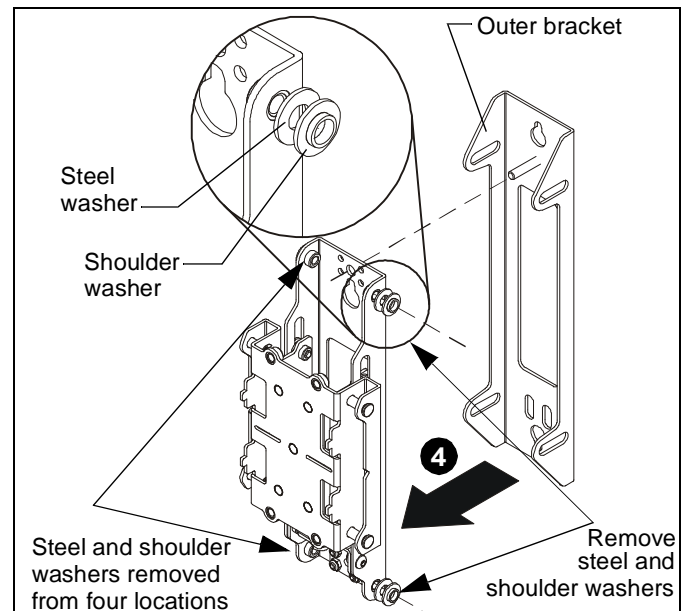

Figure 4

5. Remove four button head screws and nuts, and one small metal plate from lower side within wall upright. (See Figure 5)
6. Reinstall metal plate at top of wall upright using same hardware removed in Step 5. (See Figure 5)

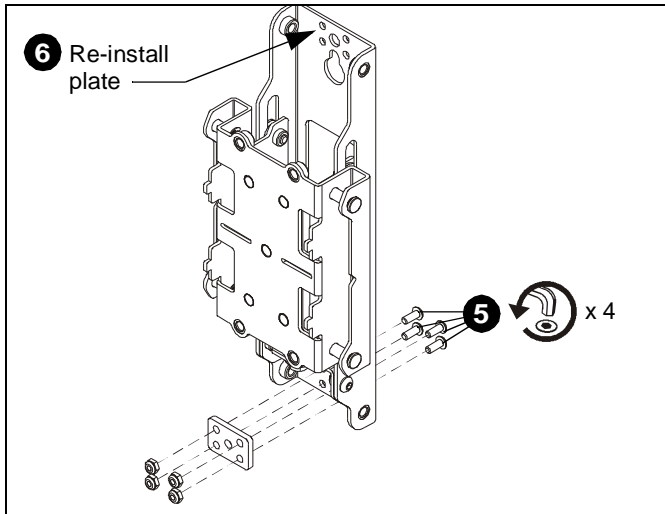

Figure 5

7. Rotate wall assembly so that height-adjust screw is at top of wall upright assembly. (See Figure 6)
8. Insert one shoulder washer and one steel washer between outer bracket and wall upright assembly in four locations.
9. Insert wall upright assembly into outer bracket by placing wall upright assembly onto threaded pem at top of outer bracket.

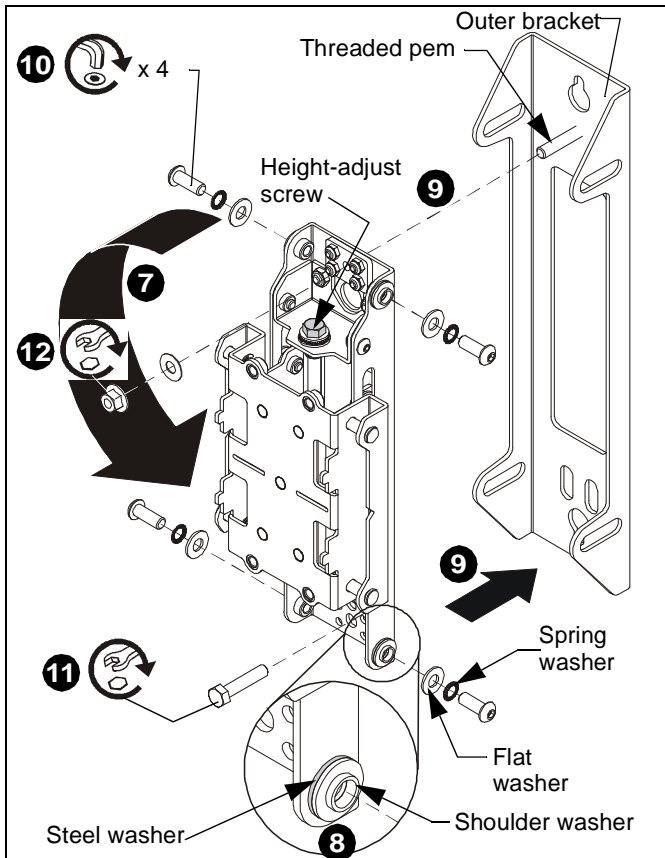

Figure 6

10. Fasten one button head screw, spring washer and flat washer into four locations on sides of wall upright.
11. Fasten hex head screw into bottom of wall upright.
12. Replace and tighten flanged nut and washer onto threaded pem at top of wall upright. (See Figure 6)

### Attach Wall Uprights

**IMPORTANT !** : Reference **Wall Placement Information** section (See Figure 1) and Table 1.

1. Use the outside wall upright (CC) or center wall upright (DD) as a model to mark upper and lower pilot hole placement for 2 outside wall uprights (and center wall upright for LWM4X1 or LWM5X1 models) following wall placement information in Figure 1 and Table 1. (See Figure 7)

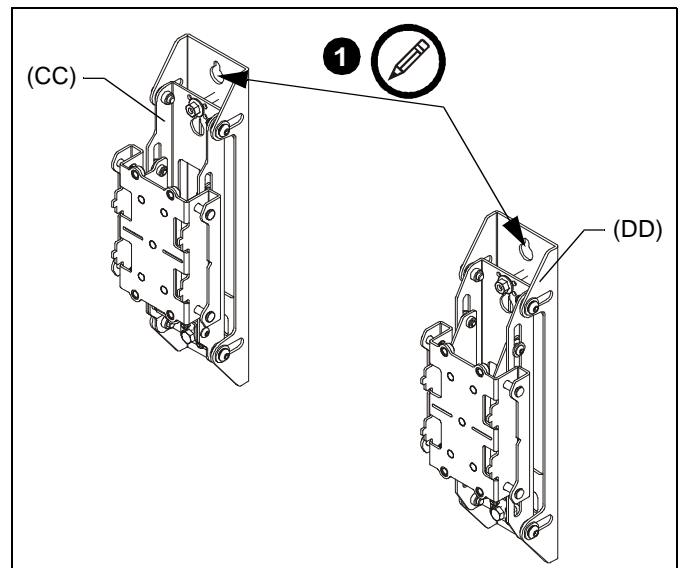

Figure 7

**IMPORTANT !** : See **Parts** drawing, Table 2 and **Installing to Wood Stud Walls** or **Installing to Concrete Walls** section for details on installing wall brackets into wood studs or concrete.

Table 2: Fastener Information

WALL TYPE	PILOT HOLE	FASTENERS (see PARTS drawing)
Wood stud (2" x 4")	7/32" x 3"	5/16 x 2-3/4" hex head lag (Y) & 5/16" slotted washer (AA). Fasteners placed at stud locations. Refer to Table 1 for proper spacing for each model.
Concrete	3/8" x 3"	5/16 x 2-3/4" hex head lag (Y) & Fischer UX10x60 anchor (Z). Refer to Table 1 for proper spacing for each model.



### Installing to Wood Stud Walls

1. Drill one 7/32" (5.5mm) pilot hole in stud at upper mounting slot. (See Figure 8)
2. Partially install one 5/16 x 2-3/4" flanged lag bolt (Y) into pilot hole but do not tighten to wall.
3. Hang outside wall upright (CC) [or center wall upright (DD)] aligning upper mounting slot over lag bolt and level upright.
4. Place one slotted washer (AA) over flanged lag bolt. (See Figure 8)
5. Tighten lag bolt to secure wall upright (CC or DD) to wall at upper mounting slot. (See Figure 8)

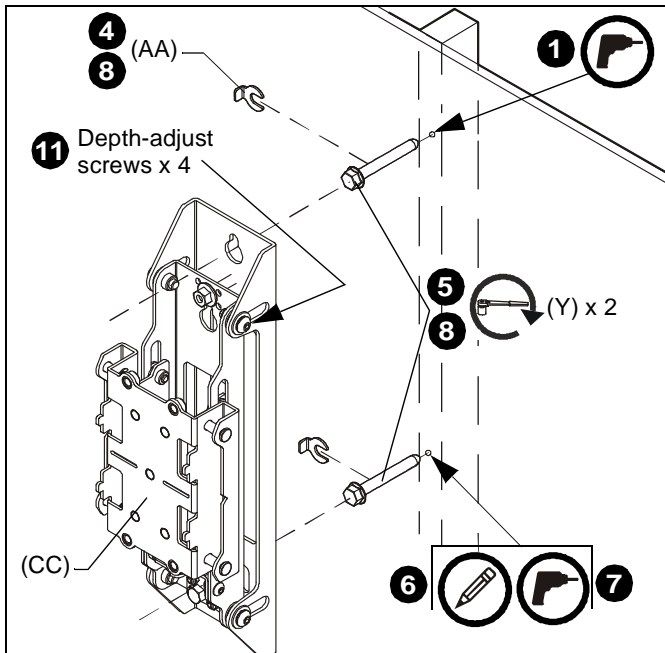

Figure 8

6. Mark the attachment point for the lower mounting slot, making sure the attachment point is located on the stud. (See Figure 8)
7. Drill 7/32" (5.5mm) pilot hole at marking for lower mounting hole. (See Figure 8)
8. Use one 5/16 x 2-3/4" flanged lag bolt (Y) and one 5/16" slotted washer (AA) to attach each wall upright to the wall through the lower mounting hole. (See Figure 8)
9. Repeat Steps 1 through 8 for remaining wall upright(s).
10. Adjust depth of wall uprights, if necessary, so that the face of the wall uprights are all in the same plane across the width of wall upright installation: (See Figure 8)
  - Loosen button head screws (4 places)
  - Adjust depth along depth-adjust slots.
  - Tighten button head screws.
11. Proceed to **Attach Mounting Rail** section.

### Installing to Concrete Walls

1. Drill one 3/8" x 3-1/2" (9.5mm x 88.9mm) pilot hole at each marking. (See Figure 9)
2. Install one anchor (Z) into each pilot hole using a hammer, making sure that the anchor is flush with the wall.
3. Partially install one 5/16 x 2-3/4" flanged lag bolt (Y) into pilot hole but do not tighten to wall.
4. Hang outside wall upright (CC) [or center wall upright (DD)] aligning upper mounting slot over lag bolt and level upright.
5. Place one slotted washer (AA) over each flanged lag bolt. (See Figure 9)
6. Tighten lag bolt to secure wall upright (CC or DD) to wall at upper mounting slot.

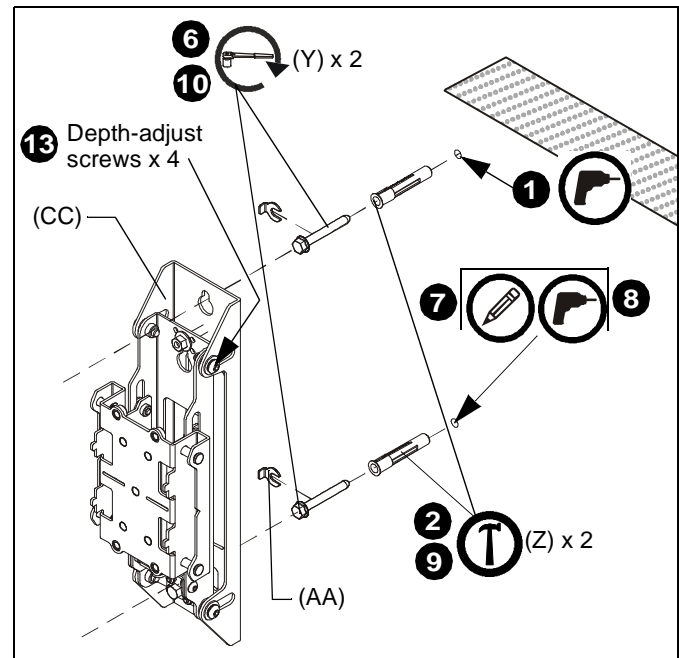

Figure 9

7. Mark the attachment point for the lower mounting slot. (See Figure 9)
8. Drill 3/8" x 3-1/2" (9.5mm x 88.9mm) pilot holes at marking for lower mounting hole. (See Figure 9)
9. Install an anchor (Z) into each pilot hole using a hammer, making sure that the anchor is flush with the wall.
10. Use one 5/16 x 2-3/4" flanged lag bolt (Y) and one 5/16" slotted washer (AA) to attach the wall upright to the wall through the lower mounting hole. (See Figure 9)
11. Repeat Steps 1 through 10 for remaining wall upright(s).
12. Adjust depth of wall uprights, if necessary, so that the face of the wall uprights are all in the same plane across the width of wall upright installation: (See Figure 8)
  - Loosen button head screws (4 places)
  - Adjust depth along depth-adjust slots.
  - Tighten button head screws.

**IMPORTANT !** : Be sure to securely tighten depth-adjust screws after adjustment.



### ATTACH MOUNTING RAIL

**IMPORTANT !** : If installing models LWM2X1 or LWM3X1, proceed to Step 7.

#### LWM4X1/LWM5X1 Models Only

1. Insert two tie bars (NN) into the slots on one section of mounting rail (Q). (See Figure 10)

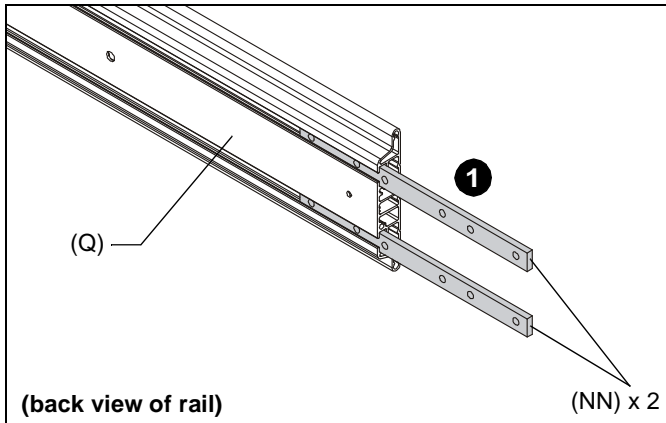

Figure 10

2. Secure connect bracket (EE) to front of mounting rail (Q) using three 10-24 x 1-1/2" flat head cap screws (JJ) fastened through one side of connect bracket, mounting rail, tie bars (NN) and into connector plate (GG). (See Figure 11)

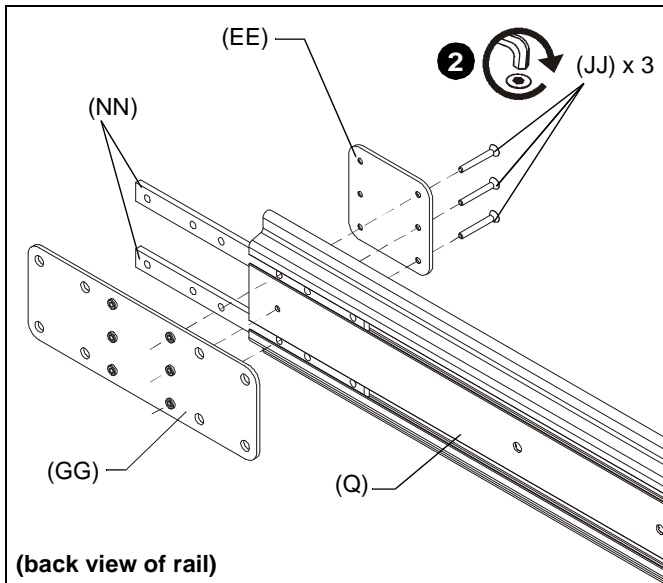

Figure 11

3. Additionally fasten connector plate (GG) using four 5/16 x 5/8" button head cap screws (HH), four 5/16" split washers (FF), and four friction washers (KK). (See Figure 12)

4. Slide second section of mounting rail (Q) over tie bars (NN) and bring it flush to first section of mounting rail. (See Figure 12)

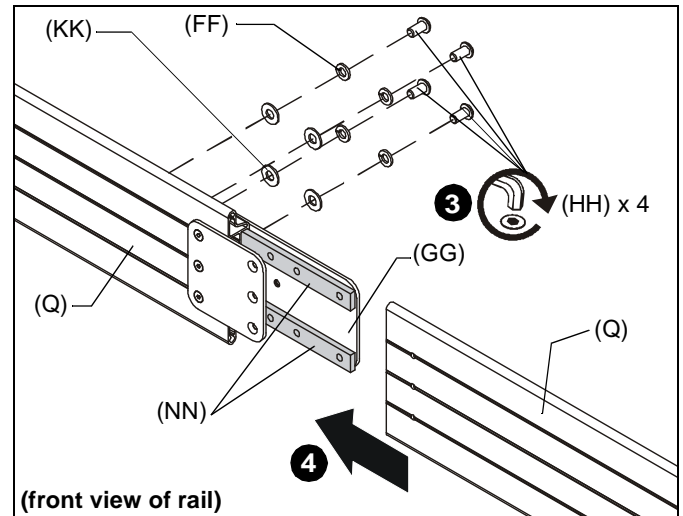

Figure 12

5. Secure connect bracket (EE) to front of second section of mounting rail (Q) using three 10-24 x 1-1/2" flat head cap screws (JJ) fastened through one side of connect bracket, mounting rail, tie bars (NN) and into connector plate (GG). (See Figure 13)
6. Additionally fasten connector plate (GG) using four 5/16 x 5/8" button head cap screws (HH), four 5/16" split washers (FF), and four friction washers (KK). (See Figure 13)

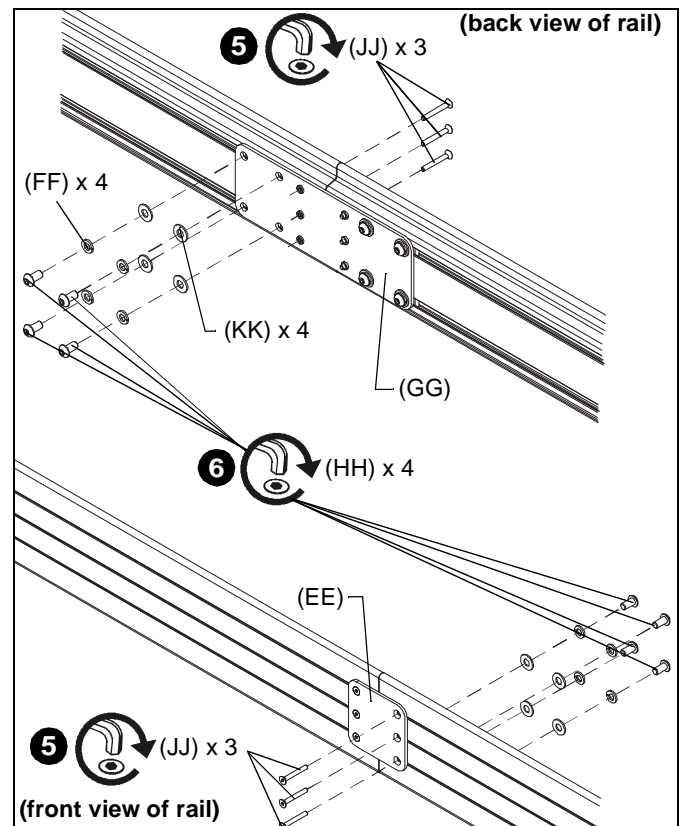

Figure 13

7. Attach one end cap (S) with two 1/4-20 x 1/2" Phillips head screws (T) to end of mounting rail (Q). (See Figure 14)

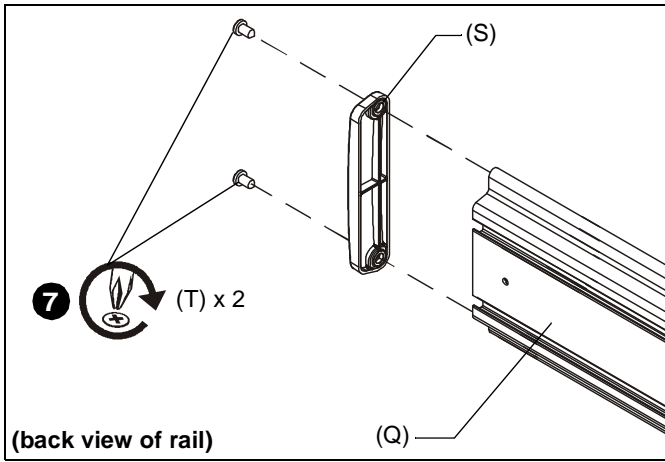

Figure 14

8. Slide height adjust plates (BB) into open end of mounting rail (Q). (See Figure 15)

- LWM2X1/LWM3X1: Insert two plates (BB)
- LWM4X1/LWM5X1: Insert three plates (BB)

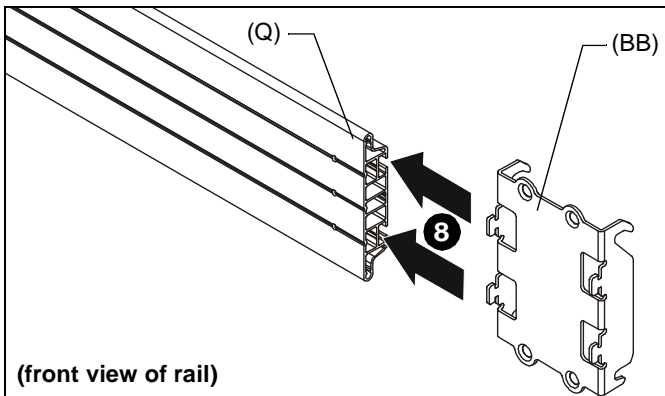

Figure 15

9. Hook height adjust plates (BB) over wall uprights (CC or DD). (See Figure 16)

**NOTE:** Hook all height adjust plates (BB) over wall uprights (CC or DD), and approximately center mounting rail over the span of the wall uprights (CC or DD) **BEFORE** proceeding to next step.

10. Fasten mounting rail (Q) to wall uprights using four 5/16 x 1/2" Phillips flat head screws (X) through height adjust plate (BB) and into wall uprights (CC or DD) and tighten all screws. (See Figure 16)

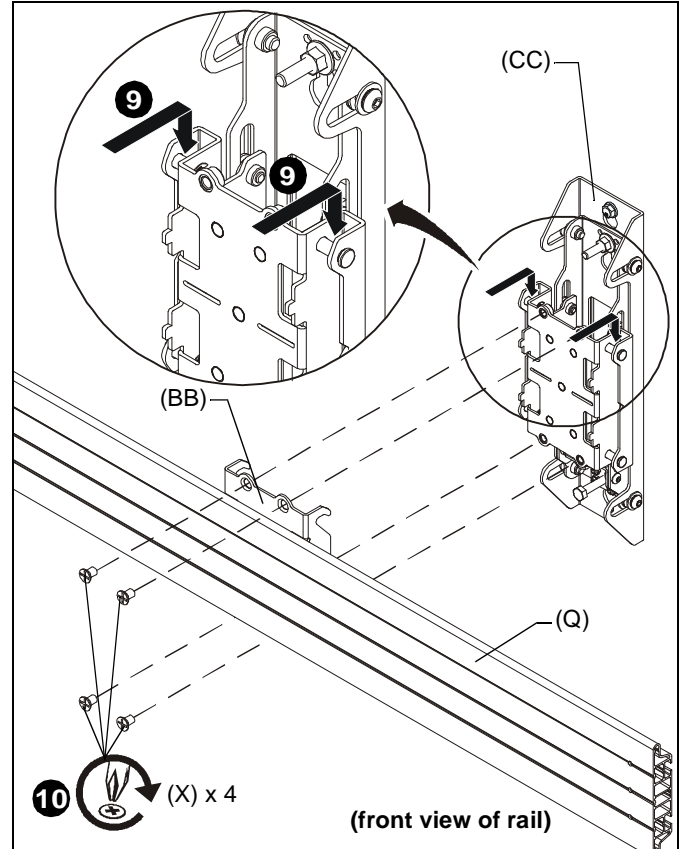

Figure 16

11. Attach one remaining end cap (S) with two 1/4-20 x 1/2" Phillips head screws (T) to end of mounting rail (Q). (See Figure 17)

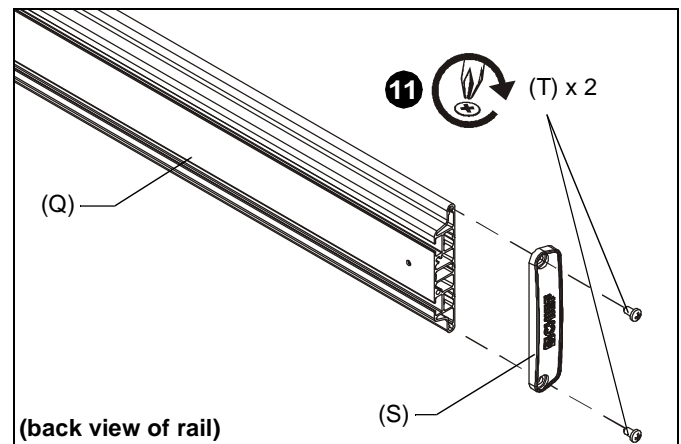

Figure 17

### Adjust and Level Mounting Rail

- Adjust the height of the mounting rail via the wall upright, as necessary, to level the mounting rail on the wall. (See Figure 18)
  - Turn the wall upright height-adjust screw **clockwise** (viewed from bottom) to **raise** the mounting rail.
  - Turn the wall upright height-adjust screw **counter-clockwise** (viewed from bottom) to **lower** the mounting rail.
- Adjust the depth of the mounting rail via the wall upright, as necessary, to make the mounting rail distance from the wall consistent.
  - Loosen depth-adjust button head screws, and move mounting rail away or toward the wall, as necessary.
  - Tighten depth-adjust button head screws.

**IMPORTANT !** : Be sure to securely tighten depth-adjust screws after adjustment.

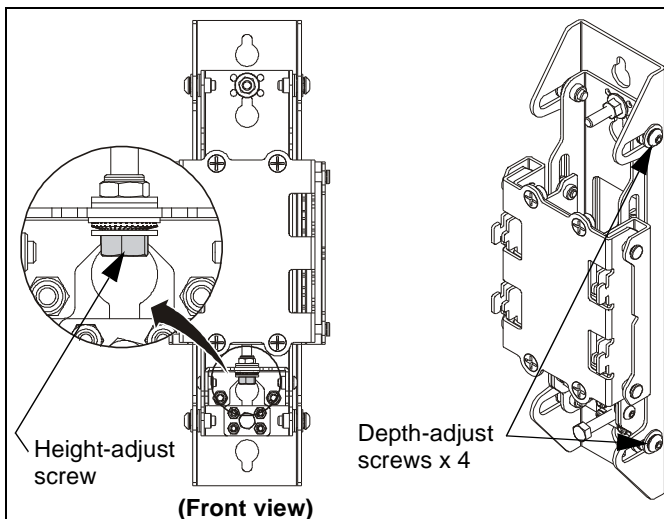

Figure 18

### INSTALL INTERFACE BRACKETS TO DISPLAYS

- Lower the latch mechanism on each interface bracket (R). (See Figure 19)

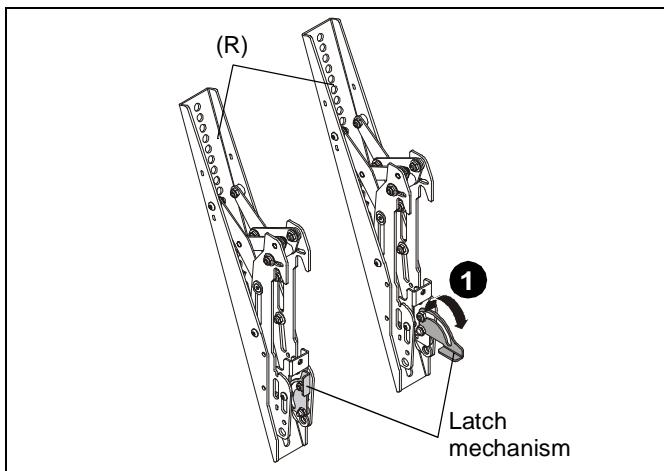

Figure 19

- Place displays face down on a soft, non-abrasive surface.
- Align the center of the interface bracket (R) with center of screen. (See Figure 20)

**NOTE:** The diamond-shape hole in the bracket corresponds to the center of the mount.

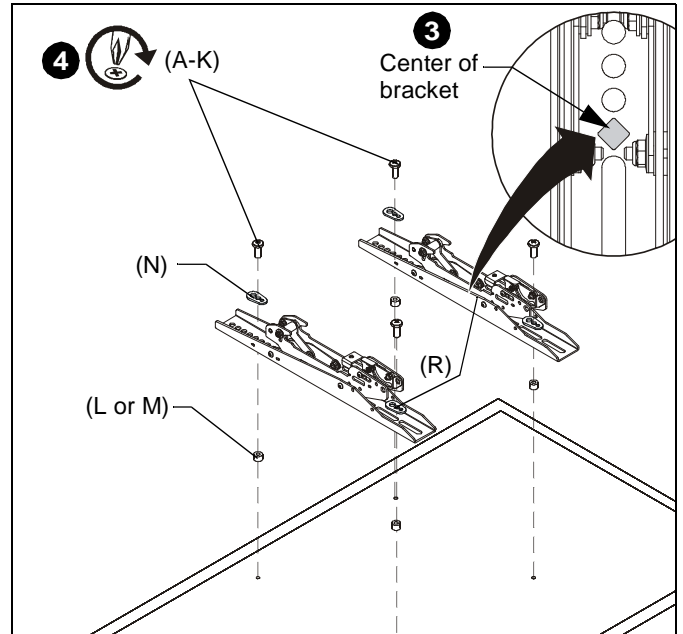

Figure 20



**WARNING:** IMPROPER INSTALLATION CAN LEAD TO DISPLAY FALLING CAUSING SERIOUS PERSONAL INJURY OR DAMAGE TO EQUIPMENT! Using screws of improper size may damage your display. Properly sized screws will easily and completely thread into display mounting holes. If spacers are required, be sure to use longer screws of the same diameter.

- Select correct screws, spacers (if necessary) and universal washers from the hardware bag (A-N) and attach brackets (R) to back of screen. (See Figure 20)

### ATTACH DISPLAYS TO MOUNTING RAIL



**WARNING:** IMPROPER INSTALLATION CAN LEAD TO DISPLAY FALLING CAUSING SERIOUS PERSONAL INJURY OR DAMAGE TO EQUIPMENT! The displays must be located approximately evenly across the length of the rail.

- Ensure that the latch mechanisms on interface brackets (R) are already lowered. (See Figure 19)

2. While supporting both sides of display, lower display onto one side of mounting rail, hooking top of interface brackets onto front of mounting rail. (See Figure 21)
3. Raise the latch mechanism on both interface brackets to lock bracket in place. (See Figure 21)

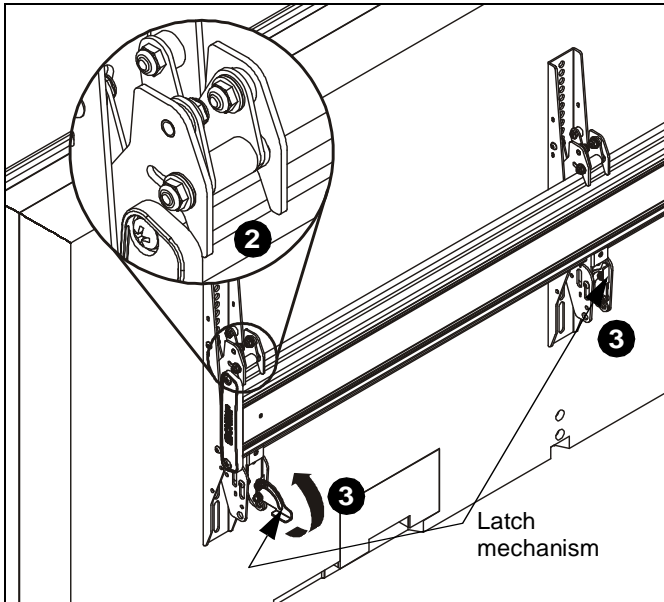

Figure 21

4. Fasten bracket against ceiling mount extrusion using one 10-24 x 5/8" button head cap screw (V). (See Figure 22)
5. Repeat for other interface bracket.

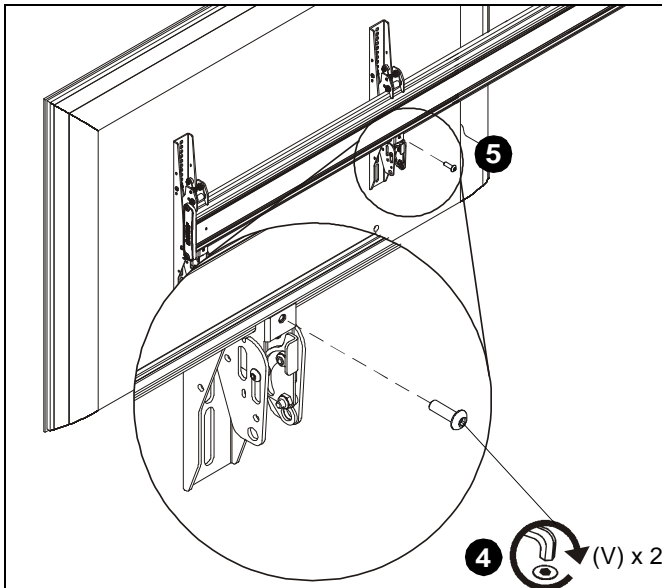

Figure 22

6. While supporting both sides of each remaining display, lower display onto mounting rail, hooking top of interface brackets onto front of mounting rail. (See Figure 21)
7. Repeat Steps 3 through 5 for each additional display.

## Interface Bracket Adjustment

### Tilt

The interface brackets allow 0° to 20° tilt, and can be locked at 0°, 10° and 20° tilt.

1. If necessary, loosen button head tilt friction bolt (located on side of interface bracket). (See Figure 23)
2. Adjust tilt as required. (See Figure 23)
3. The tilt may be locked at 0°, 10° and 20° using one 10-24 x 2-1/4" Phillips head screw (W) and one 10-24 lock nut (U) per interface bracket. (See Figure 23)
4. Tighten tilt friction bolt as necessary.

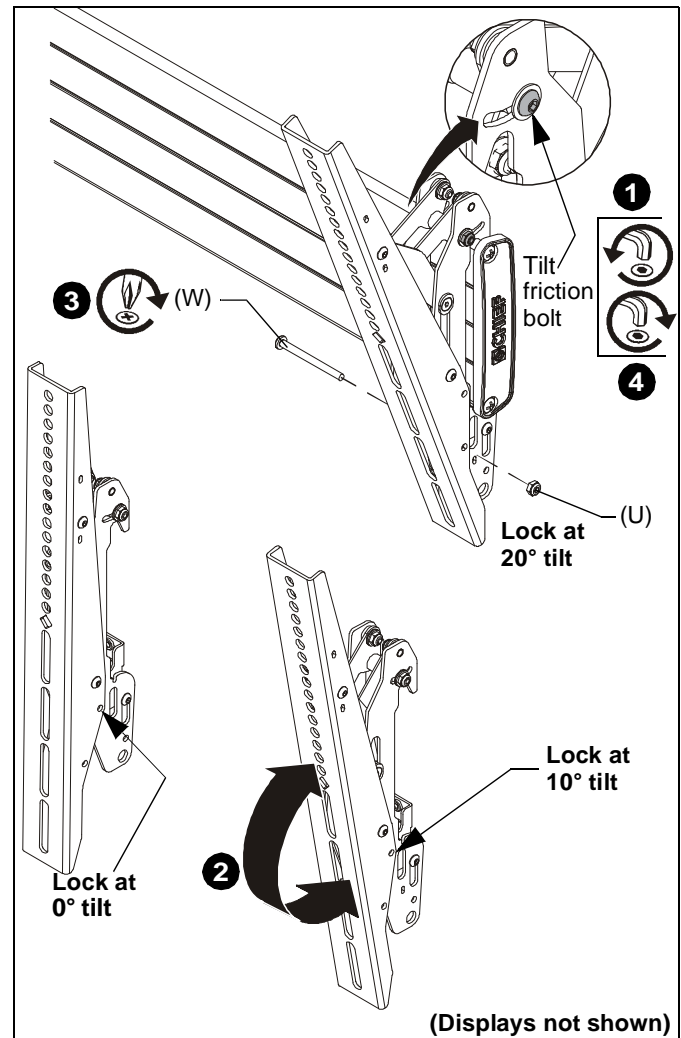
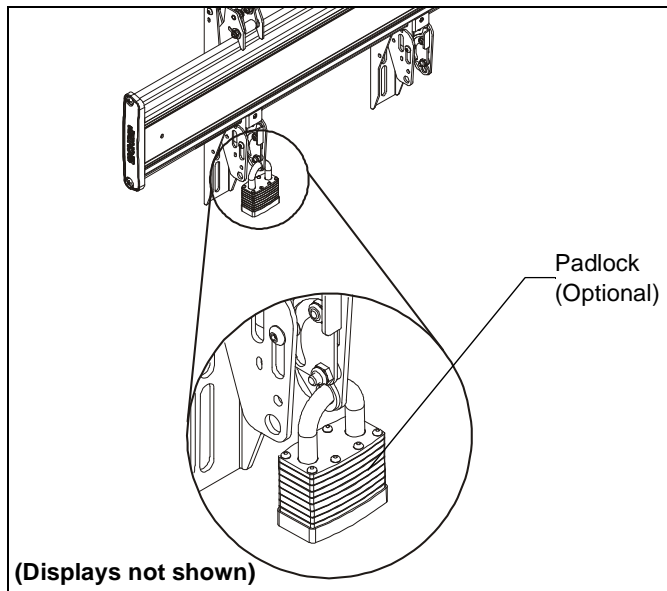

Figure 23

**OPTIONAL: Security**

1. **OPTIONAL:** Add padlock (not included) to each interface bracket to lock display to menu board. (See Figure 24)

**Figure 24**

**DIMENSIONS**

**LWM2X1U**

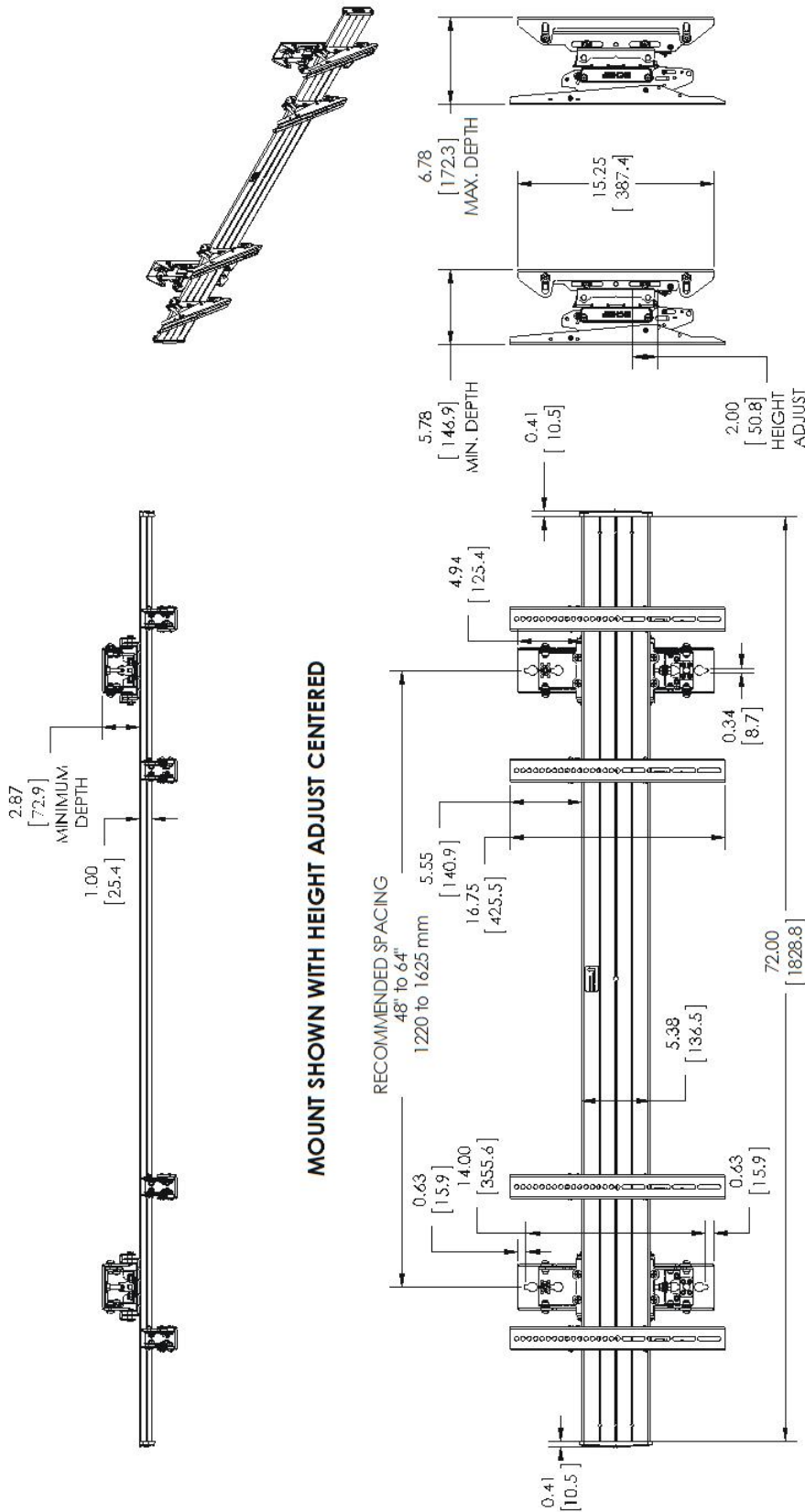

**MOUNT SHOWN WITH HEIGHT ADJUST CENTERED**

3 WIDE LAMPSCOPE			
EXTENSION LENGTH (IN.)	MINIMUM SCREEN WIDTH TO HOLES (IN.)	INCLUDING PATTERN WIDTH (IN.)	TOTAL SCREEN WIDTH (IN.)
72	36.5	6.00	92.63
		4.00	84.13
		3.00	75.06
		2.00	61.00

DIMENSIONS: INCHES [MILLIMETERS]

**DIMENSIONS (continued)**

**LWM2X1U**

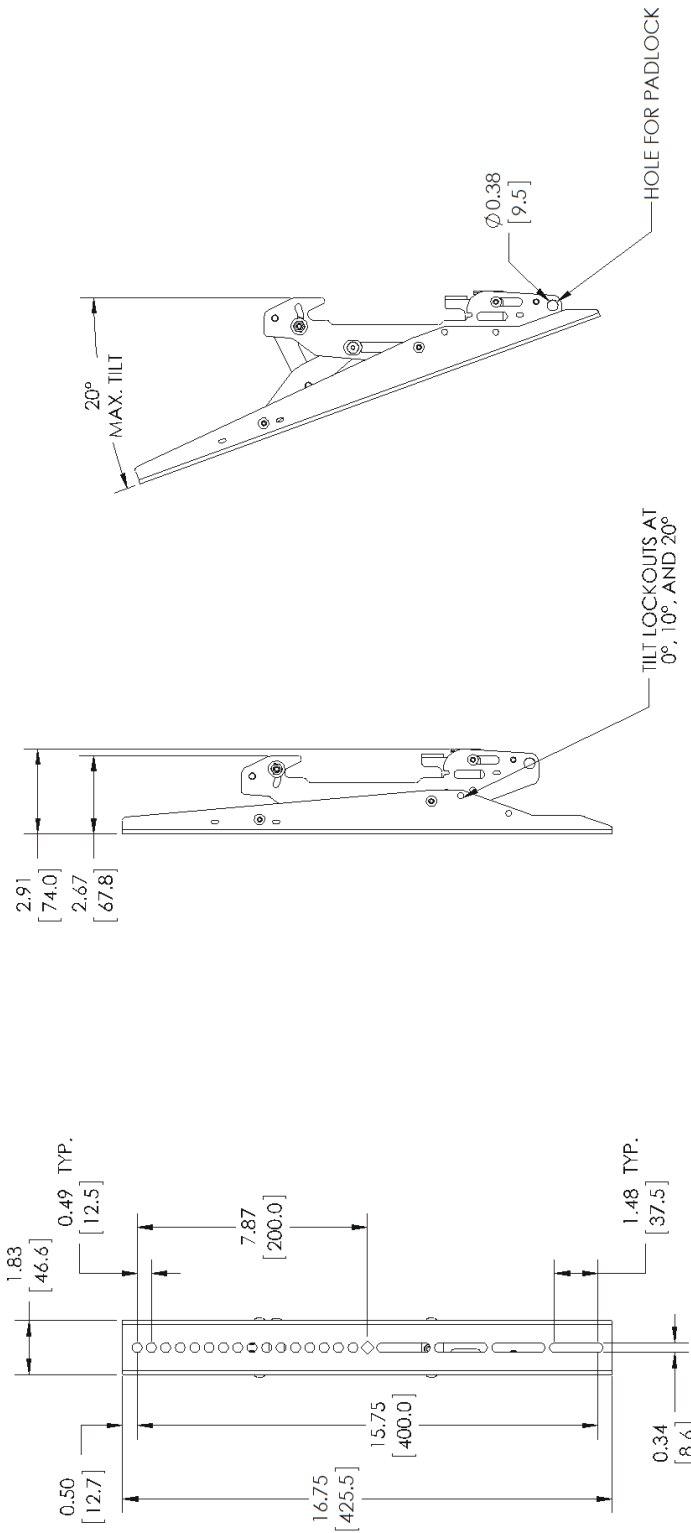

DIMENSIONS: INCHES [MILLIMETERS]





**DIMENSIONS (continued)**

**LWM3X1U**

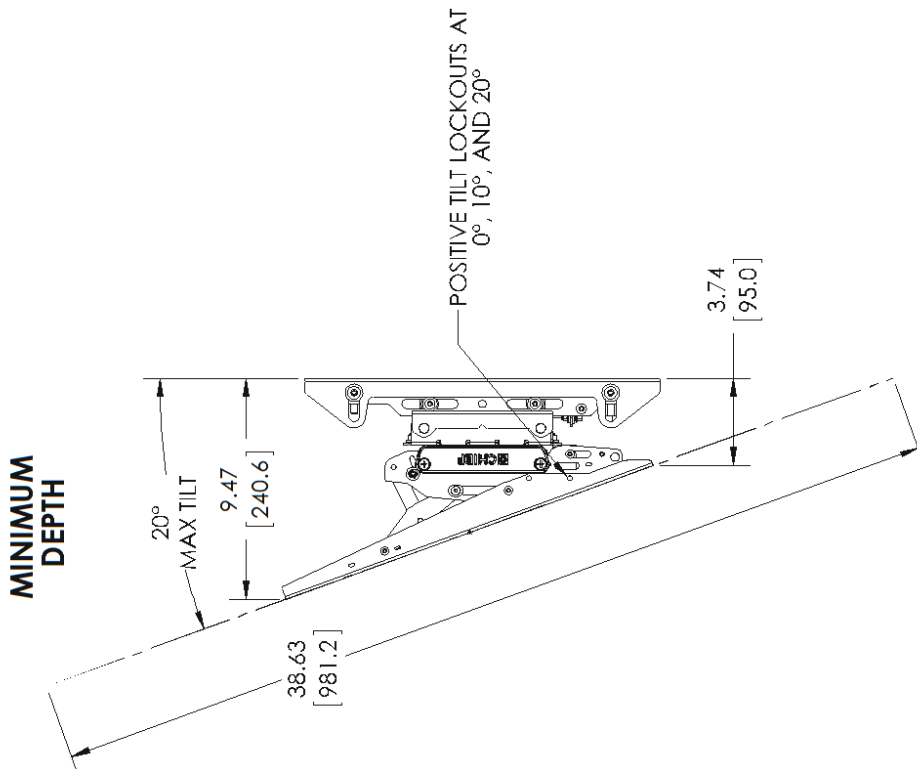
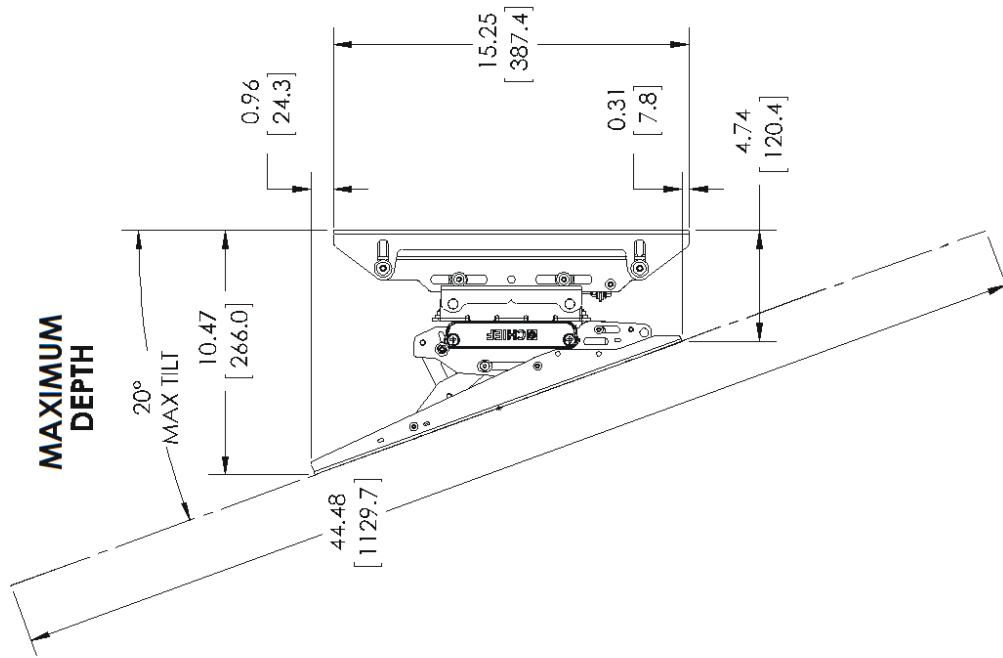

DIMENSIONS: INCHES  
[MILLIMETERS]

**DIMENSIONS (continued)**

**LWM4X1U**

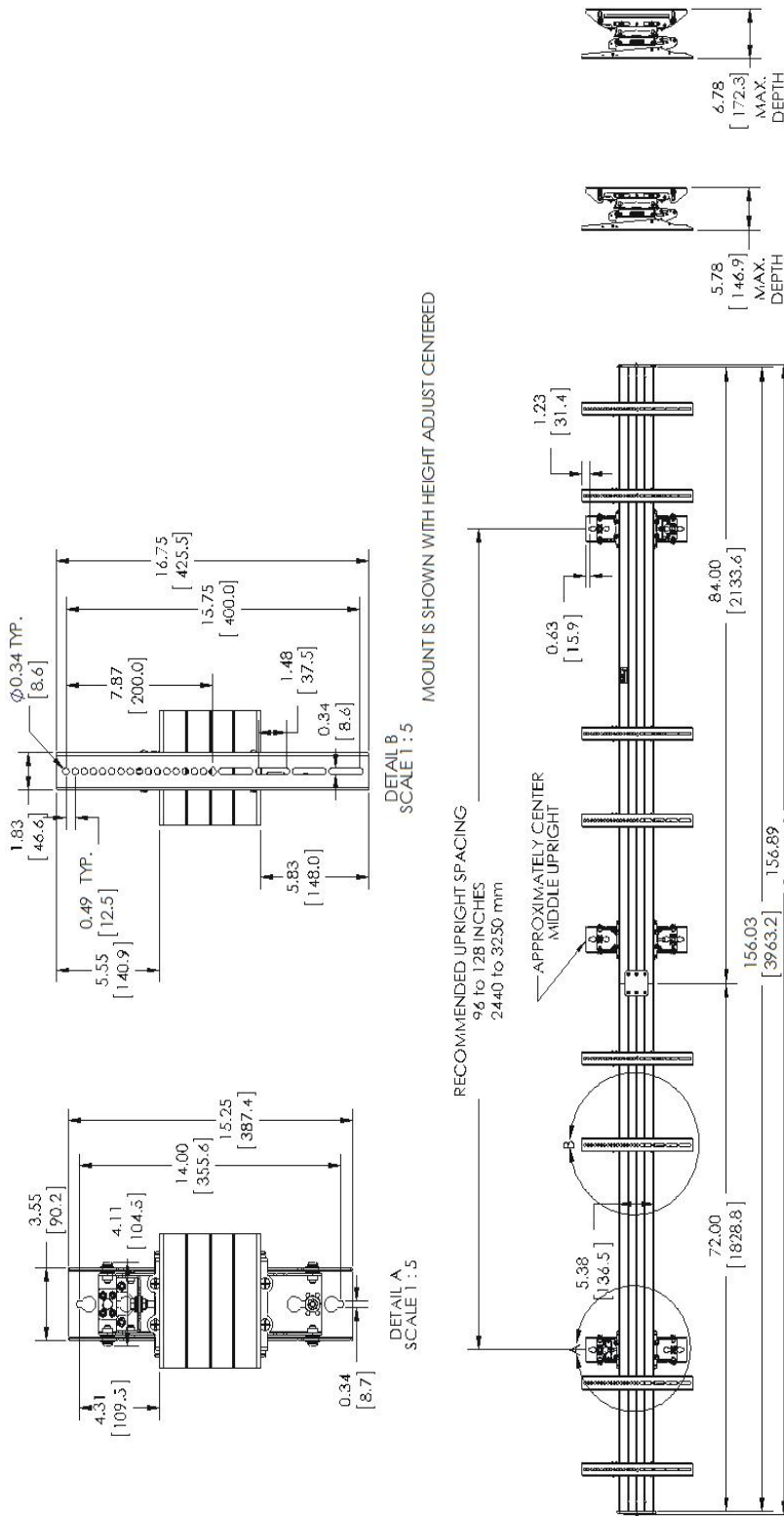

6" WIDE LANDSCAPE			
STANDARD LENGTH (IN.)	NUMBER OF BEES PER FOOT	NUMBER OF BEES PER FOOT TO FORM A LINE	NUMBER OF BEES PER FOOT TO FORM A CURVE
156	95.25	400	300
		300	180.34
		200	124.58
		43.40	173.77
		46.02	184.09
		47.33	189.34
		48.65	194.58

DIMENSIONS: INCHES  
[MILLIMETERS]

**DIMENSIONS (continued)**

**LWM4X1U**

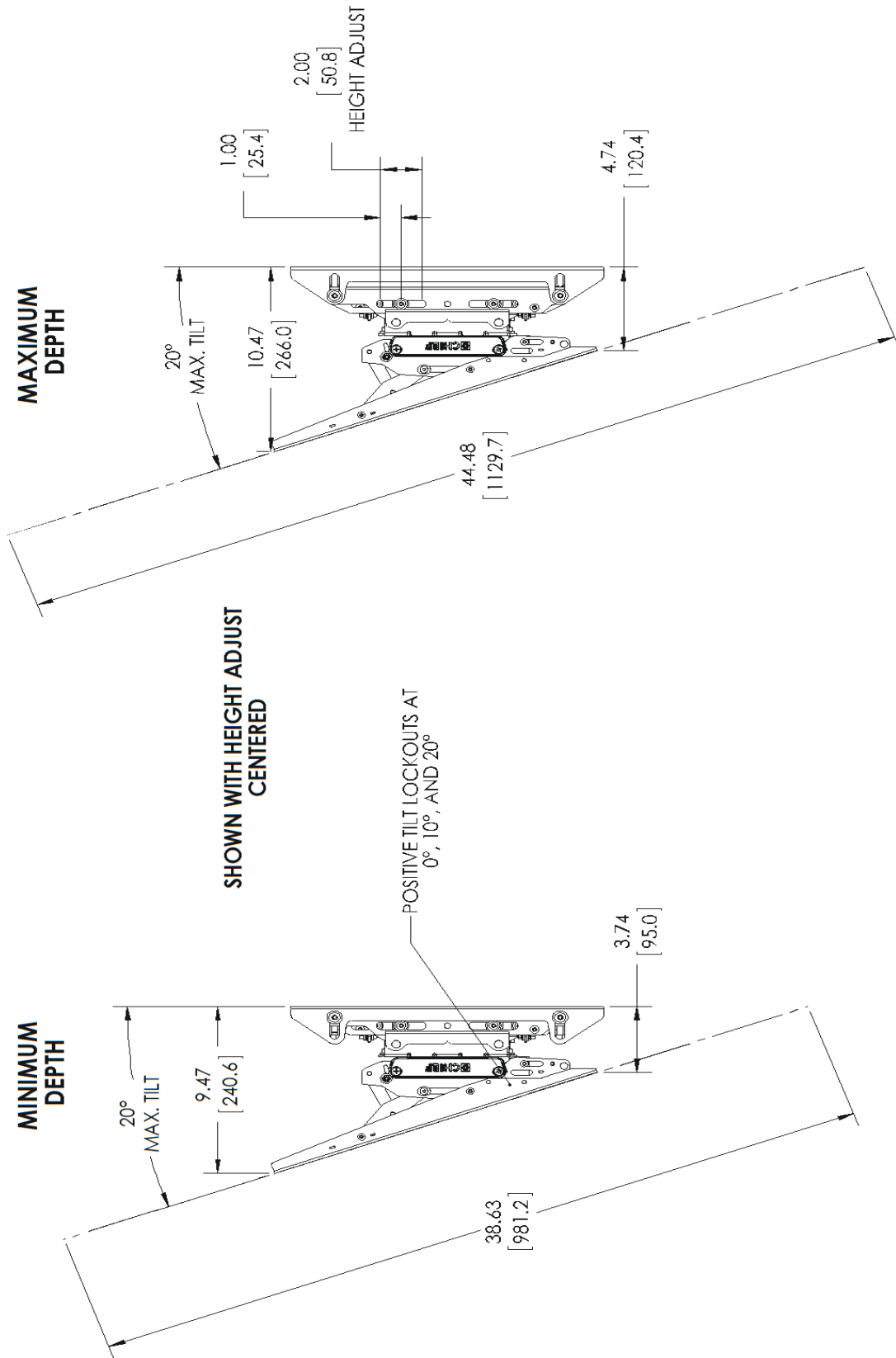

DIMENSIONS: INCHES  
[MILLIMETERS]

**DIMENSIONS (continued)**

**LWM5X1U**

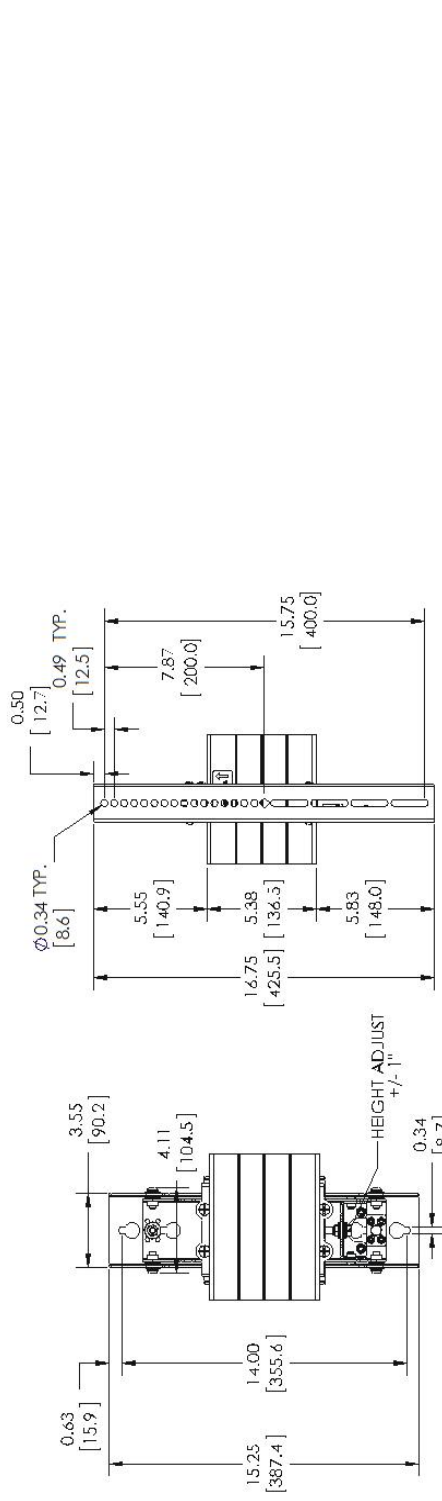

DETAIL B  
SCALE 1 : 5

DETAIL A  
SCALE 1 : 5

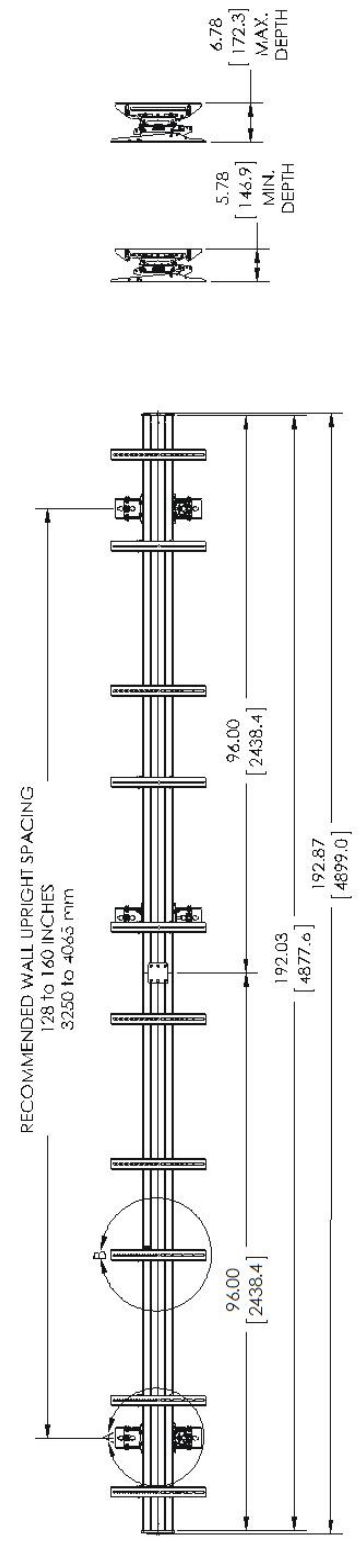

DIMENSIONS: INCHES  
[MILLIMETERS]

**DIMENSIONS (continued)**

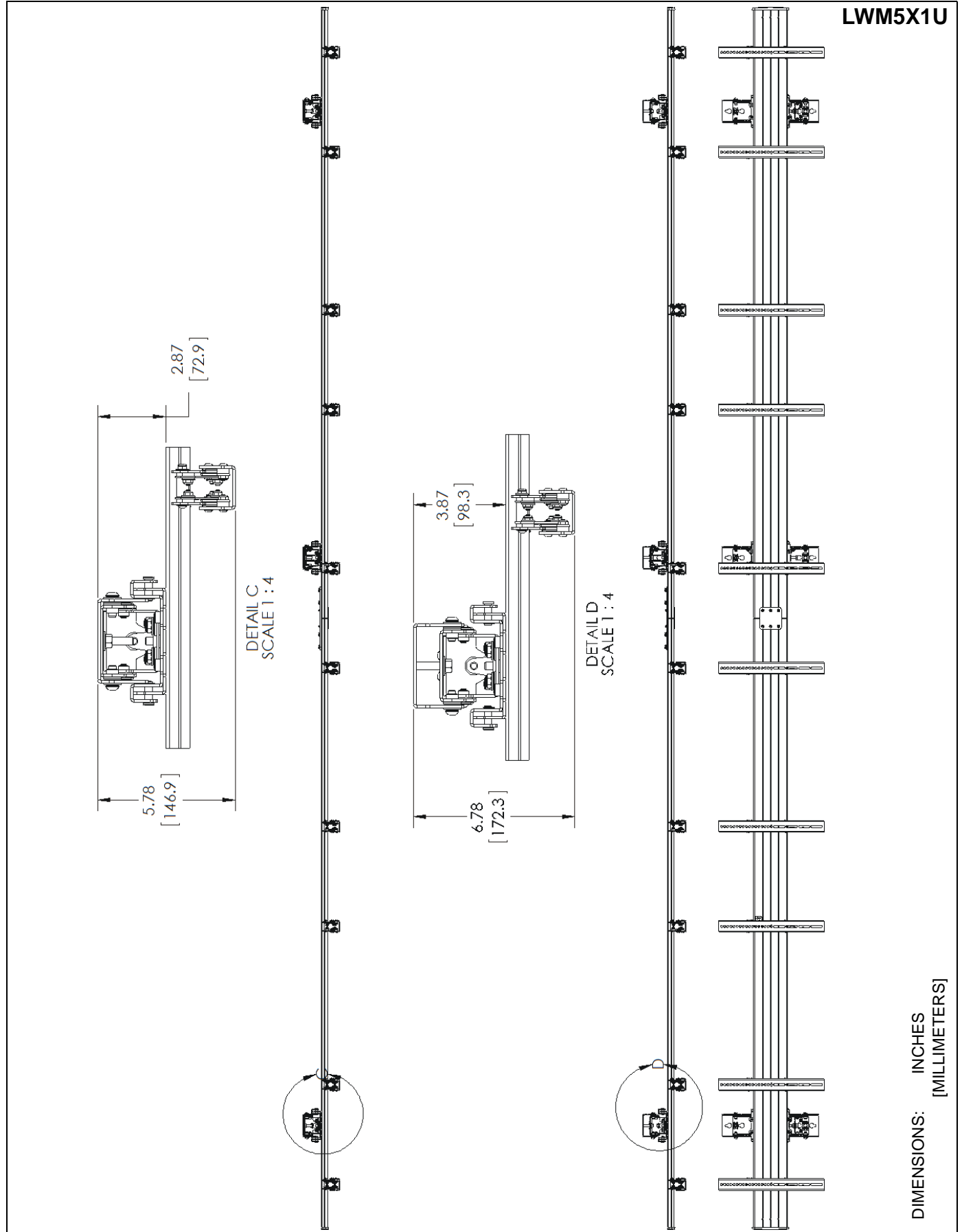

DIMENSIONS: INCHES  
[MILLIMETERS]

**DIMENSIONS (continued)**

**LWM5X1U**

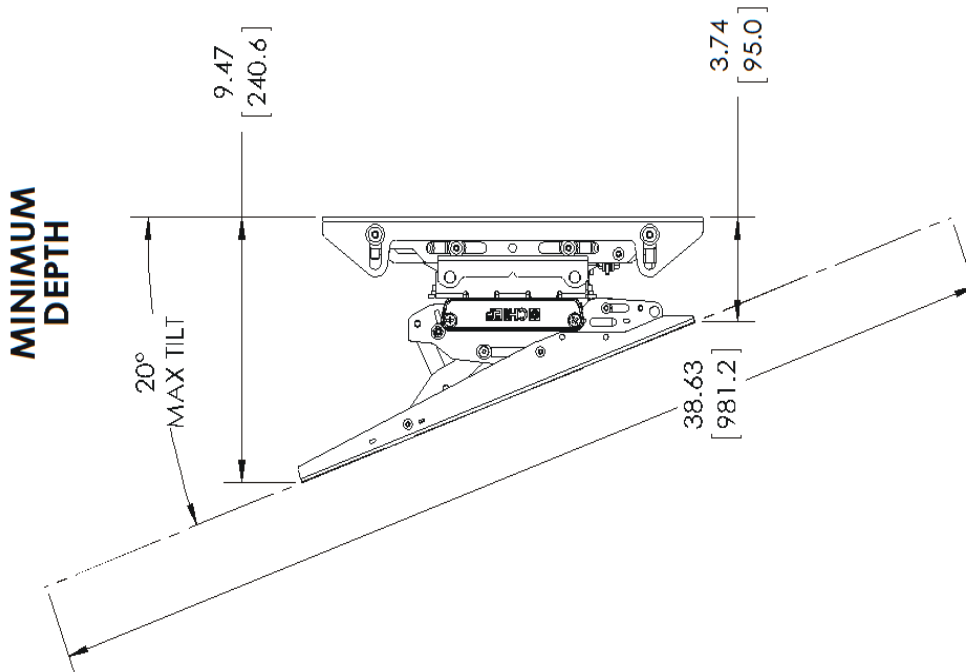
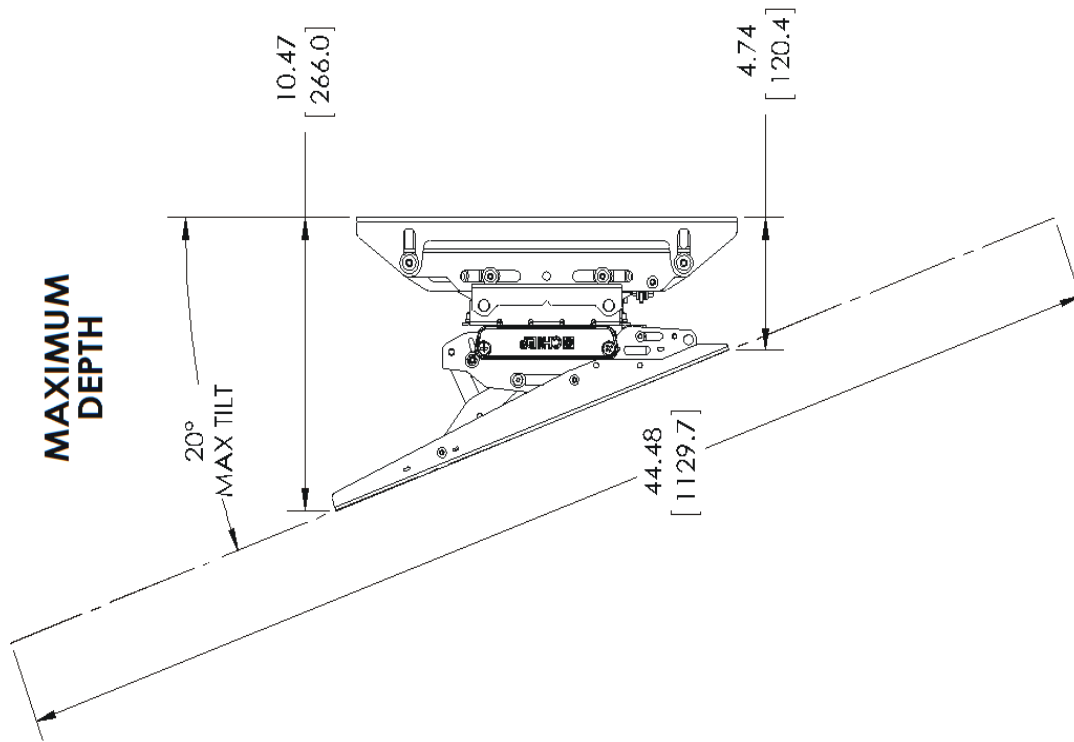

DIMENSIONS: INCHES  
[MILLIMETERS]







Our Mounts. **Your Vision.**

Chief, a products division of  
Milestone AV Technologies

8800-002779 Rev02  
©2015 Milestone AV Technologies  
[www.chiefmfg.com](http://www.chiefmfg.com)  
11/15

<b>USA/International</b>	<b>A</b> 6436 City West Parkway, Eden Prairie, MN 55344 <b>P</b> 800.582.6480 / 952.225.6000 <b>F</b> 877.894.6918 / 952.894.6918
<b>Europe</b>	<b>A</b> Franklinstraat 14, 6003 DK Weert, Netherlands <b>P</b> +31 (0) 495 580 852 <b>F</b> +31 (0) 495 580 845
<b>Asia Pacific</b>	<b>A</b> Office No. 918 on 9/F, Shatin Galleria 18-24 Shan Mei Street Fotan, Shatin, Hong Kong <b>P</b> 852 2145 4099 <b>F</b> 852 2145 4477

