



FEATURES

- 1 CLICKCONNECT™ LATCHING**
Hear an audible click when the screen engages with the mount. Easy to connect/disconnect - no tools needed!
- 2 BOLT-DOWN SECURITY**
Optional free-standing with bolt-down capability for permanent installations and security.
- 3 SMOOTH SWIVEL**
Smooth swivel up to 45° in either direction. Optional stops at 15°, 25° and 35°.
- 4 CABLE MANAGEMENT**
Internal routing pathways conceal cables while allowing cables to exit through back of stand or down grommet hole.

WHAT YOU NEED TO KNOW

ORDERING OPTIONS

Available in custom and universal.

- MSSV = VESA 100 x 100 mm, 200 x 100 mm, 200 x 200 mm and 400 x 200 mm patterns
- MSSxxxx = Custom (see MountFinder™ Pro at chiefmfg.com)
- MSSU = MSS + MSBU (see MountFinder Pro at chiefmfg.com)

SPECIFICATIONS

Height	22.41 - 27.66" (569 - 703 mm)
Swivel	±15°, 25°, 35°, 45°
Weight Capacity	100 lbs (45.5 kg)
Colors	Black, Silver



205 Westwood Ave, Long Branch, NJ 07740
 Phone: 866-94 BOARDS (26273) / (732)-222-1511
 Fax: (732)-222-7088 | E-mail: sales@touchboards.com

RECOMMENDED ACCESSORIES



PAC150 ■ Video Conferencing Camera Shelf



PACLR1 ■ Left/Right Speaker Adapter

TECHNICAL DRAWINGS

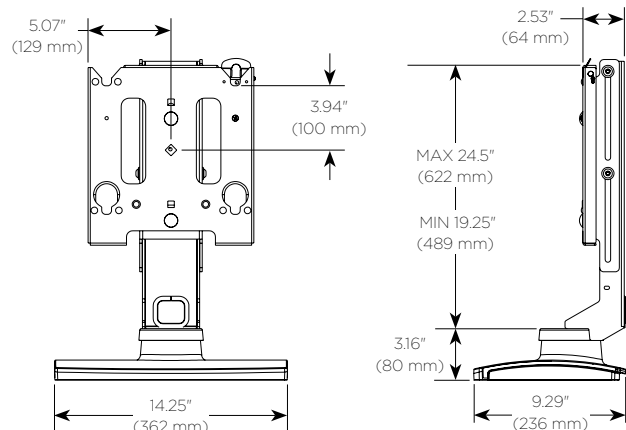

For a complete list of cart & stand accessories see pages 93 - 94.