

INSTALLATION INSTRUCTIONS

PSB-2136

LCD DISPLAY MOUNTING BRACKET

Prior to assembly, unpack carton completely and verify contents.

If you are missing any of the following components, please contact Customer Service at 1-800/582-6480

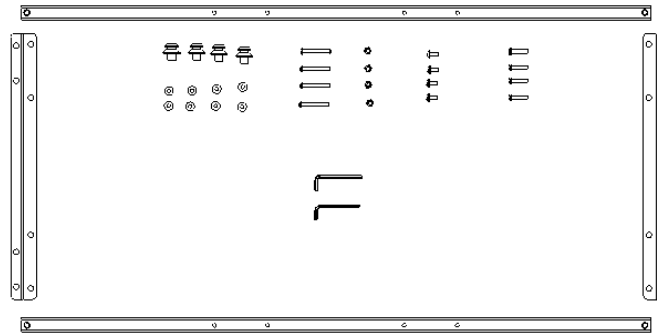

- | | | |
|---|----------|---|
| (2) LCD Interface Side Brackets | Figure 1 | (2) LCD Interface Center Brackets |
| (4) M5-.8 x 25mm Phillips Head Cap Screw | | (4) 1/4-20 x .5" Button Head Cap Screws |
| (1) 5/32" Allen Key | | (1) 1/8" Allen Key |
| (4) Mounting Buttons-Black Nylon | | (8) .50 x .194 x .375 Nylon Spacer |
| (4) 10-24 x 1 5/8" Button Head Cap Screws | | (4) 10-24 Nylock Nuts |

BEFORE PROCEEDING, READ INSTALLATION INSTRUCTIONS COMPLETELY

CAUTION! LCD DISPLAYS ARE EXTREMELY FRAGILE.

- Using a 10-24 button head cap screw, nylon spacer and nylock nut, secure mounting button to center bracket (four places) (see Figure 2 & Figure 3).

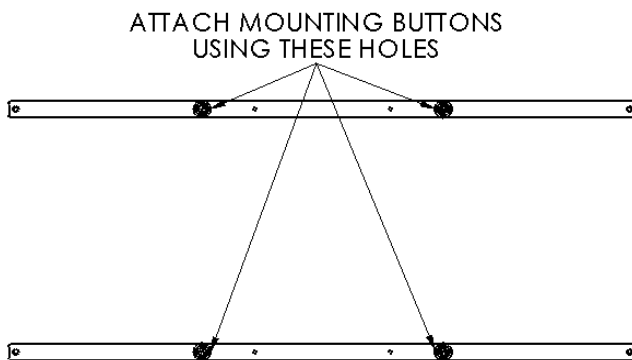

Figure 2

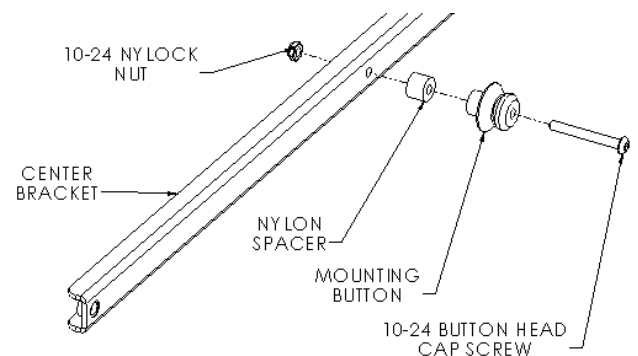

Figure 3

2. Attach center brackets to side brackets using the 1/4-20 screws (see Figure 4 & Figure 5).

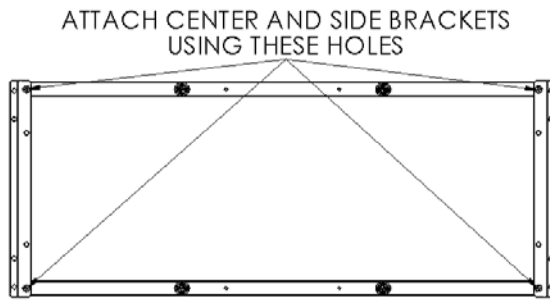

Figure 4

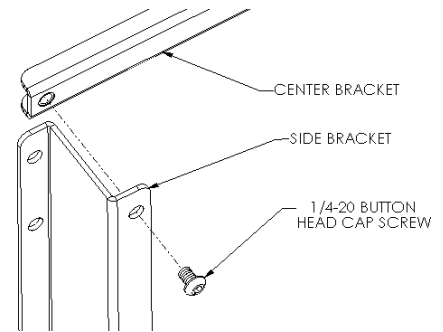

Figure 5

3. Place the four remaining nylon spacers over mounting holes on the back of the panel.
4. Using M5 screws, secure side brackets to display (see Figure 6 & Figure 7). Do not over tighten screws. The 1/4-20 button head cap screws attaching the side and center brackets may need to be loosened in order to line up holes on display. If this is done, please be sure to tighten them once again.
5. With the aid of another person, lift LCD Display up to the Chief Mount, aligning buttons of mounting brackets with slots in the Chief Mount.
6. Lower safety latch on the Chief Mount to secure LCD Display, making sure latch is completely engaged.

ATTACH BRACKETS TO DISPLAY
USING THESE HOLES

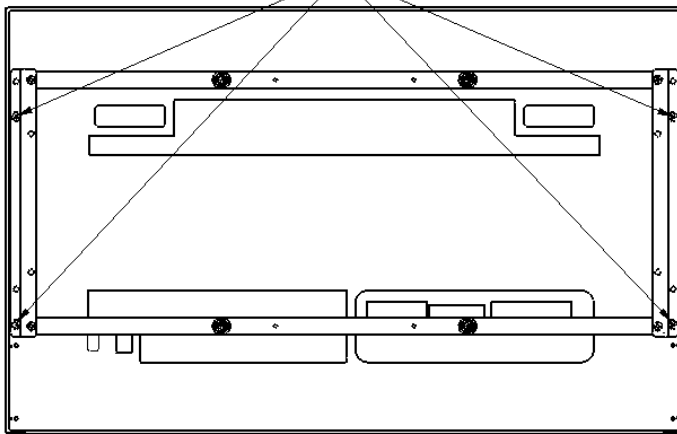

Figure 6

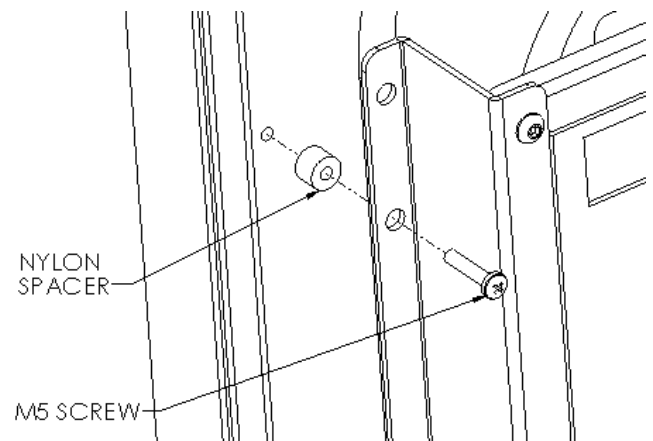

Figure 7