



## INSTALLATION INSTRUCTIONS

# PSB-2270 LCD DISPLAY MOUNTING BRACKET

Prior to assembly, unpack carton completely and verify contents.

If you are missing any of the following components, please contact Customer Service at 1-800/582-6480

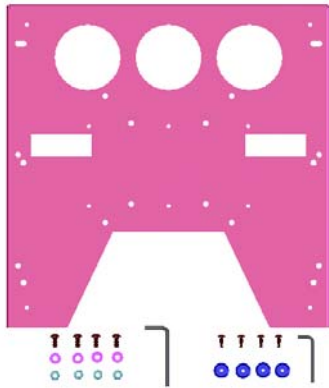

Figure 1

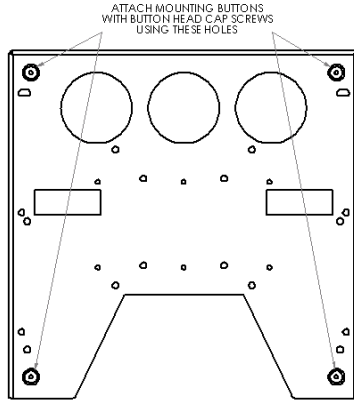

Figure 2

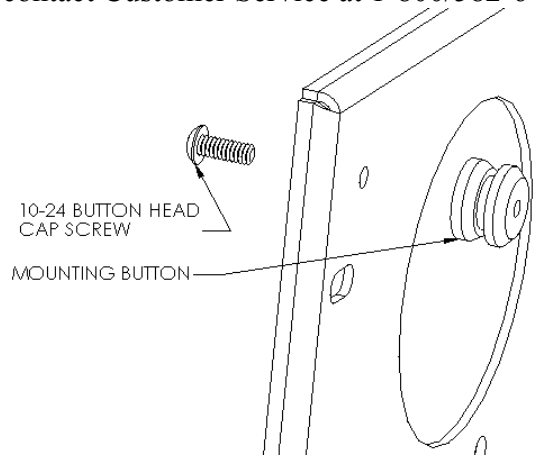

Figure 3

- (1) LCD Bracket
- (4) 10-24 x .5" Button Head Cap Screws
- (4) .255 x .563 x .060 Flat Washer
- (1) 1/8" Allen Key

- (4) Mounting Buttons-Tapped 10-24
- (4) 1/4 - 20 x 5/8" Button Head Cap Screws
- (4) 1/4 - 20 Nylock Nuts
- (1) 5/32" Allen Key

BEFORE PROCEEDING, READ INSTALLATION INSTRUCTIONS COMPLETELY

## CAUTION! LCD DISPLAYS ARE EXTREMELY FRAGILE.

1. Using a 10-24 button head cap screw inserted from back side of bracket, secure mounting button, with chamfered hole of mounting button (larger surface) facing bracket, to bracket (four places) (see Figure 2 & Figure 3).
2. Remove mounting plate from back of display.
3. Align hole pattern on brackets with pattern on back of plate (see Figure 4 & Figure 5) and attach bracket using the 1/4-20 screws, washers and Nylock nuts.
4. Reattach mounting plate to back of display (see Figure 6 & Figure 7). Make sure locking mechanism is to the side (unlocked position) before placing plate on display. Once in place, secure plate to back of screen by moving locking arm to down position.

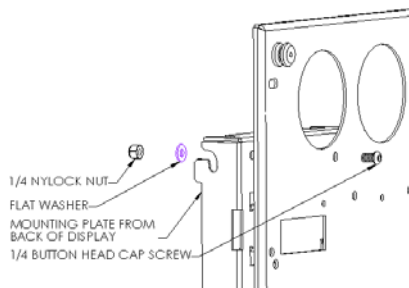

Figure 4

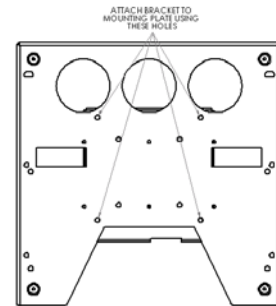

Figure 5

5. With the aid of another person, lift Plasma Display up to the Chief Mount, aligning buttons of mounting brackets with slots in the Chief Mount.
6. Lower safety latch on the Chief Mount to secure Plasma Display, making sure latch is completely engaged.

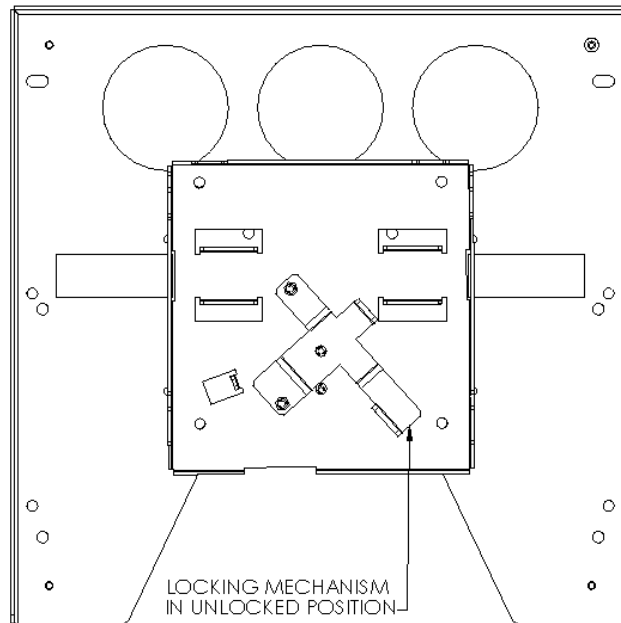

Figure 6

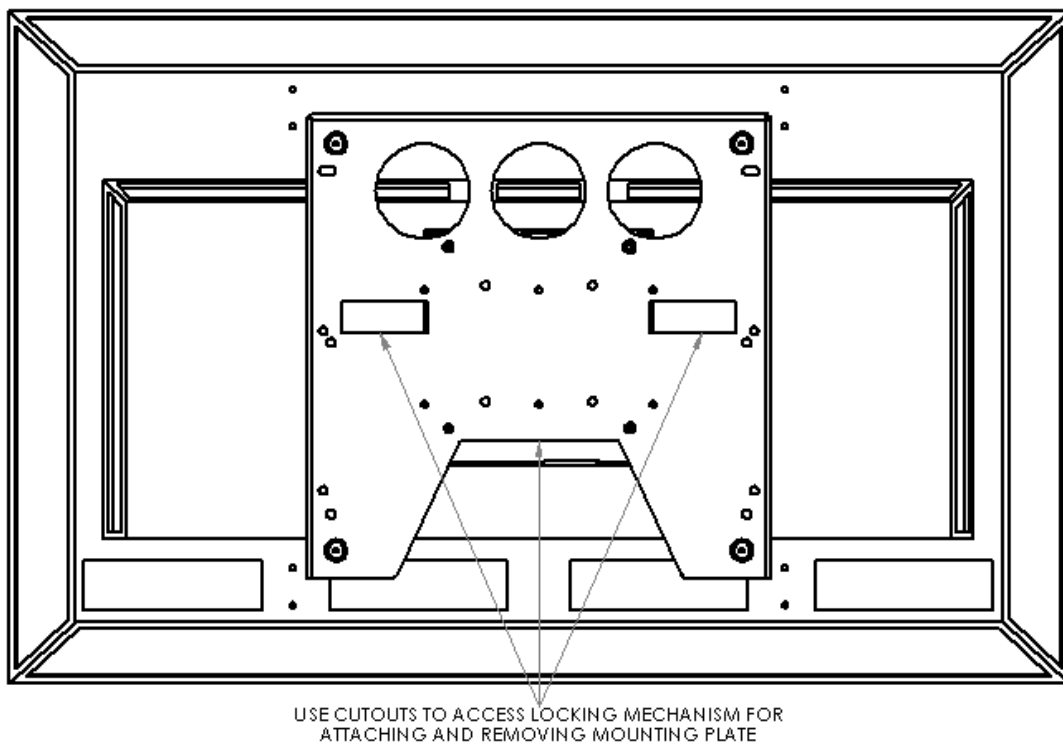

Figure 7