

INSTALLATION INSTRUCTIONS

PSB-2541 LCD DISPLAY MOUNTING BRACKET

Prior to assembly, unpack carton completely and verify contents.

If you are missing any of the following components, please contact Customer Service at 1-800/582-6480.

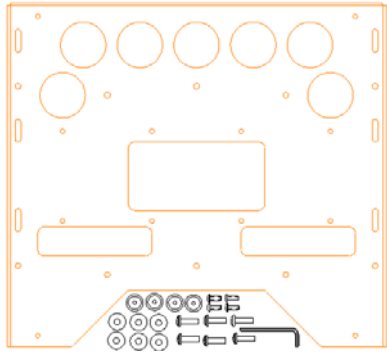

Figure 1

- (1) LCD Interface Bracket
- (4) 10-24 x .5" Button Head Cap Screws
- (6) .75 ID x .26 OD x .313 Round Nylon Spacer

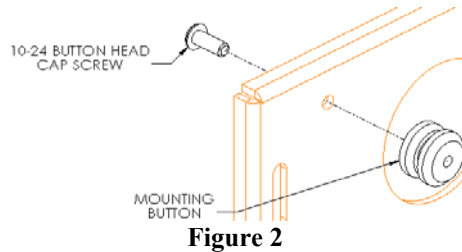

Figure 2

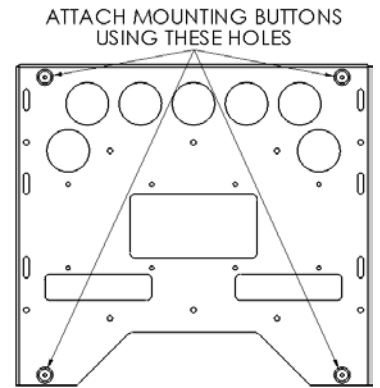

Figure 3

- (4) Mounting Buttons-Tapped 10-24
- (6) M6-1.0 x 20mm Phillips Head Cap Screws
- (1) 1/8" Allen Key

BEFORE PROCEEDING, READ INSTALLATION INSTRUCTIONS COMPLETELY.

CAUTION! LCD DISPLAYS ARE EXTREMELY FRAGILE.

1. Using a 10-24 button head cap screw inserted from back side of bracket, secure mounting button, with chamfered hole of mounting button (larger surface) facing bracket, to bracket (four places) (see Figure 2 and Figure 3).
2. Place nylon spacers on mounting holes, aligning hole pattern on brackets with pattern on back of LCD Display (see Figure 4 and Figure 5).
3. Using M6 Phillips head screws, secure brackets to display. Do not over tighten screws.
4. With the aid of another person, lift LCD Display up to the Chief Mount, aligning buttons of mounting brackets with slots in the Chief Mount.
5. Lower safety latch on the Chief Mount to secure LCD Display, making sure latch is completely engaged.

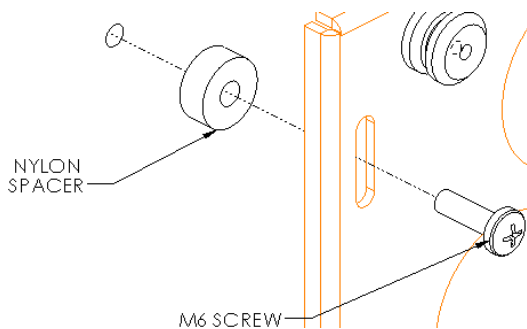

Figure 4

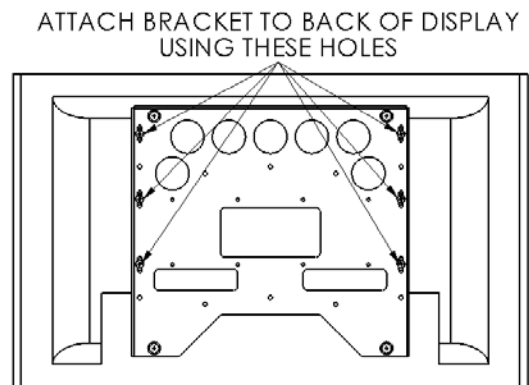

Figure 5