



FEATURES

- 1 LOW PROFILE**
Designed to ensure mount remains concealed behind the screen.
- 2 SMOOTH EXTENSION**
Contoured swing arms are designed for effortless extension up to 22" (559 mm).
- 3 CENTRIS[®] FINGERTIP TILT**
Effortlessly adjust display using Centris fingertip tilt technology. Screen angle stays set until you decide to readjust.
- 4 CLICKCONNECT[™] LATCHING**
Hear an audible click when the screen engages with the mount. Easy to connect/disconnect - no tools needed!

Touchboards

205 Westwood Ave, Long Branch, NJ 07740
Phone: 866-94 BOARDS (26273) / (732)-222-1511
Fax: (732)-222-7088 | E-mail: sales@touchboards.com



SPECIFICATIONS

Roll	±2°
Tilt	-15°, +5°
Swivel*	60° Left/Right
Extension Range	0.5" - 22" (13 - 559 mm)
Box Dimensions (HxWxD)	20" x 30" x 3.63" (508 x 762 x 92 mm)
Color	Black
Weight Capacity	125 lbs (56.7 kg)

* With 42" screen. Swivel range varies with screen size.

WHAT YOU NEED TO KNOW

ORDERING INFORMATION

PAC501 and MWRIW must be ordered separately. Available in universal or custom:

- **UNIVERSAL:** Order PAC501 and MWRIWUB
- **CUSTOM:** Order PAC501, MWRIW6000B + PSBxxxx
See MountFinder[™] PRO on chiefmfg.com for custom PSB model numbers.

OTHER PRODUCT OPTIONS

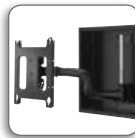

PAC501 & PWRIW
In-Wall Box Accessory
and Swing Arm Mount



MIWRF
In-Wall Swing
Arm Mount

TECHNICAL DRAWINGS

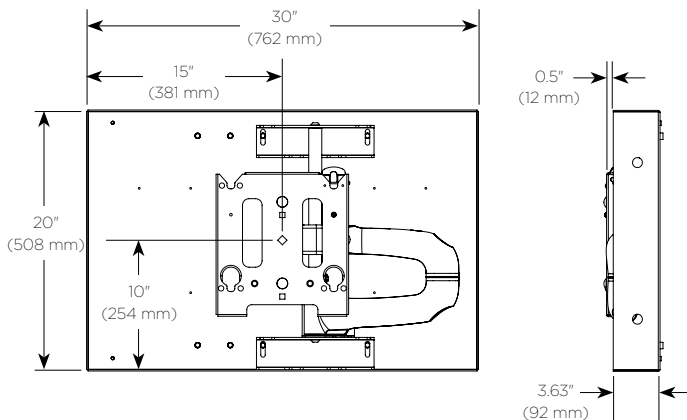

RECOMMENDED ACCESSORIES



PACHFK1 ■ Header/Footer Kit



PACCC1 ■ Center Channel
Speaker Adapter



PACPC1 ■ Power Filter

For a complete list of TV mount accessories see page 86.