

---

# INSTALLATION INSTRUCTIONS

---

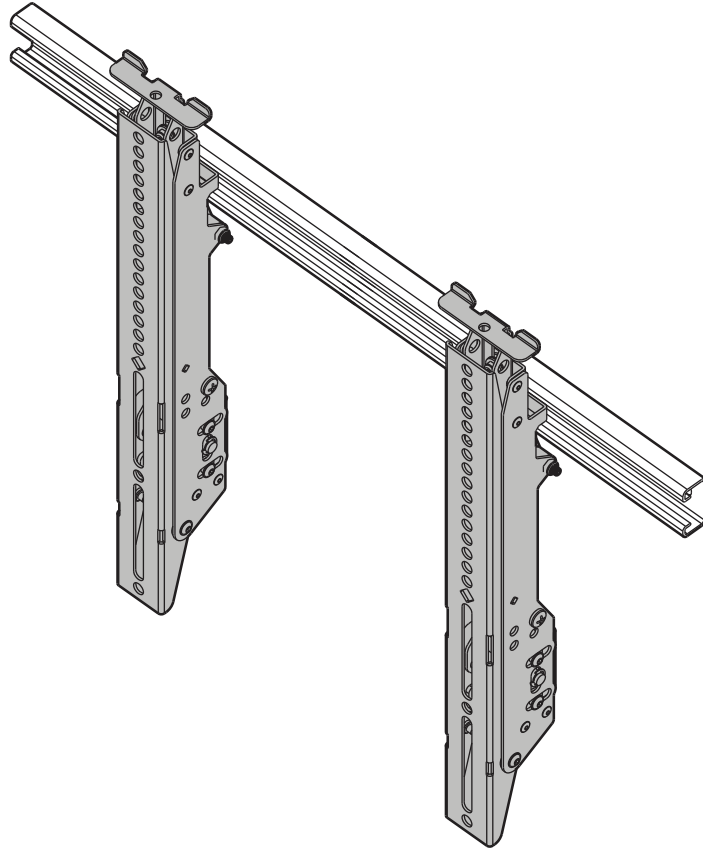

---

## 400mm FIT Menu Board Interface

---

## DISCLAIMER

Milestone AV Technologies and its affiliated corporations and subsidiaries (collectively "Milestone"), intend to make this manual accurate and complete. However, Milestone makes no claim that the information contained herein covers all details, conditions or variations, nor does it provide for every possible contingency in connection with the installation or use of this product. The information contained in this document is subject to change without notice or obligation of any kind. Milestone makes no representation of warranty, expressed or implied, regarding the information contained herein. Milestone assumes no responsibility for accuracy, completeness or sufficiency of the information contained in this document.

Chief® is a registered trademark of Milestone AV Technologies. All rights reserved.

## DEFINITIONS

**MOUNTING SYSTEM:** A MOUNTING SYSTEM is the primary Chief product to which an accessory and/or component is attached.

**ACCESSORY:** AN ACCESSORY is the secondary Chief product which is attached to a primary Chief product, and may have a component attached or setting on it.

**COMPONENT:** A COMPONENT is an audiovisual item designed to be attached or resting on an accessory or mounting system such as a video camera, CPU, screen, display, projector, etc.

**WARNING:** A WARNING alerts you to the possibility of serious injury or death if you do not follow the instructions.

**CAUTION:** A CAUTION alerts you to the possibility of damage or destruction of equipment if you do not follow the corresponding instructions.

## IMPORTANT SAFETY INSTRUCTIONS

**WARNING:** Failure to read, thoroughly understand, and follow all instructions can result in serious personal injury, damage to equipment, or voiding of factory warranty! It is the installer's responsibility to make sure all parts are properly assembled and installed using the instructions provided.

**WARNING:** Failure to provide adequate structural strength for this accessory can result in serious personal injury or damage to equipment! It is the installer's responsibility to make sure the structure to which the mounting system is attached can support five times the combined weight of all equipment.

**WARNING:** Exceeding the weight capacity can result in serious personal injury or damage to equipment! It is the installer's responsibility to make sure the combined weight of all components located on the accessory does not exceed 75 lbs (34.0 kg).

**WARNING:** Use this accessory only for its intended use as described in these instructions. Do not use attachments not recommended by the manufacturer.

**WARNING:** Never operate this accessory if it is damaged. Return the accessory to a service center for examination and repair.

**WARNING:** Do not use this product outdoors.

**IMPORTANT ! :** The RMB400 accessory is designed to be mounted to a strut channel (not included) having the following characteristics: (See Figure 1)

- 12 or 14 gauge ASTM A1011, SS GR 33
- Yield Strength: 33 ksi (230 Mpa)

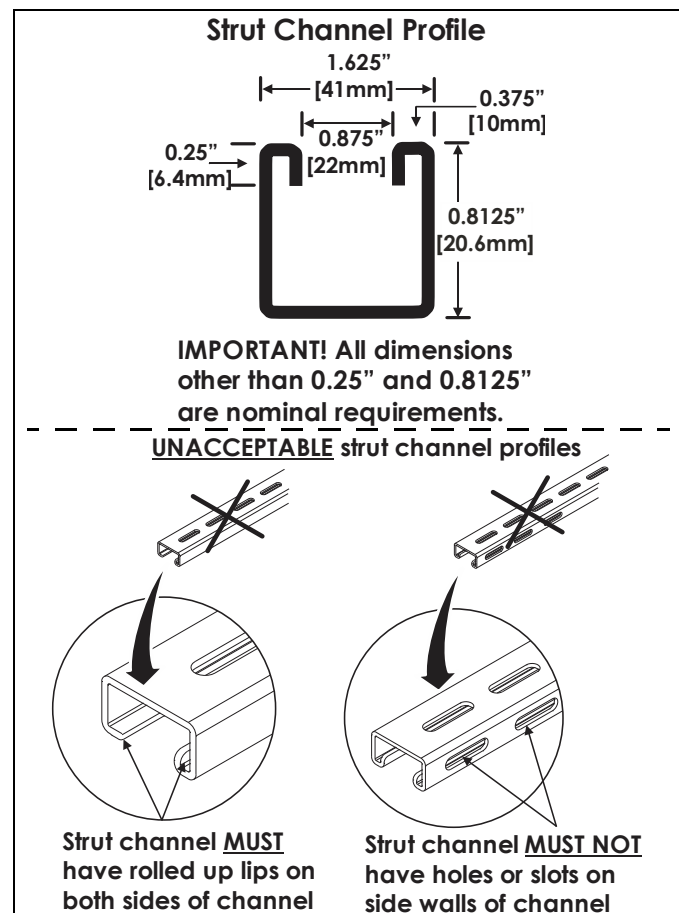
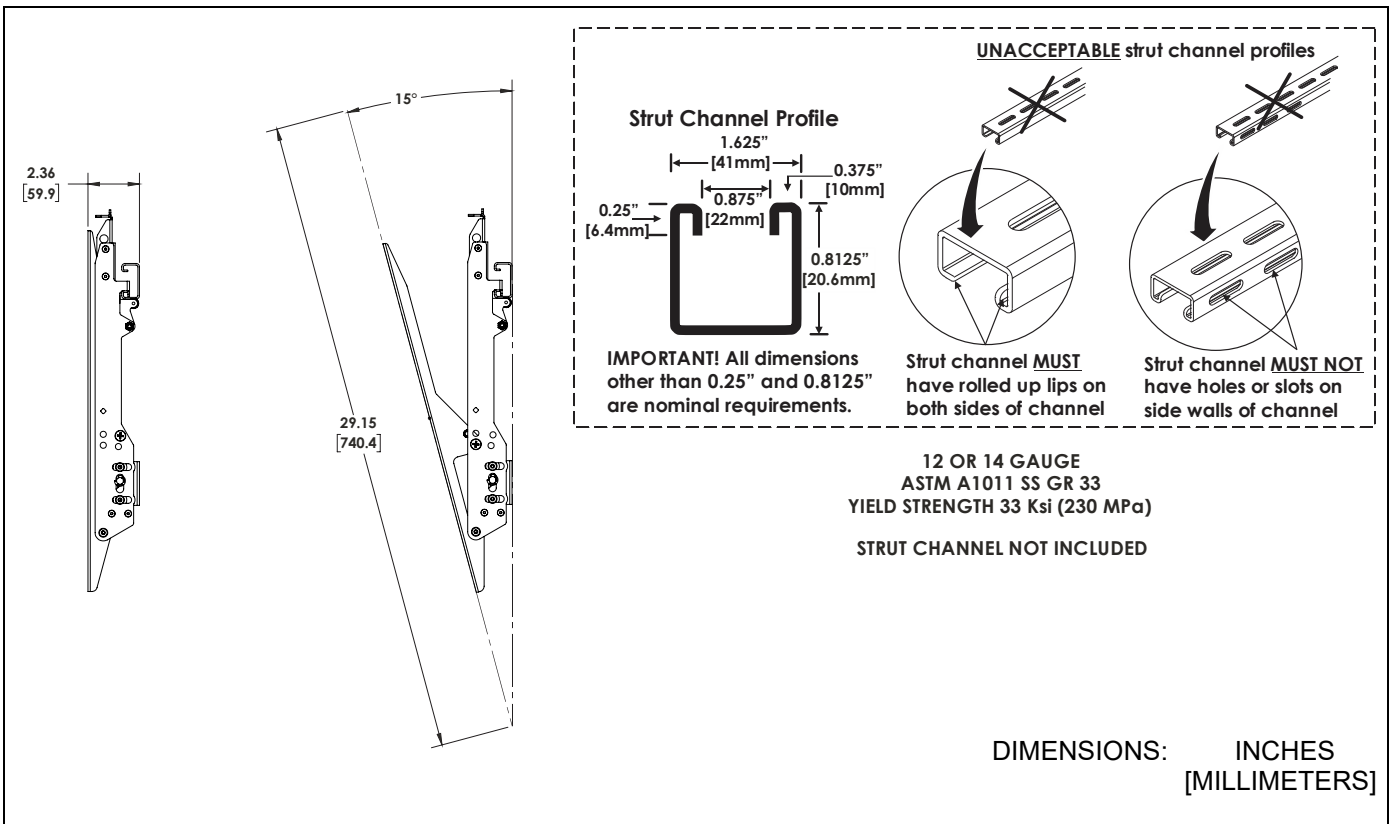
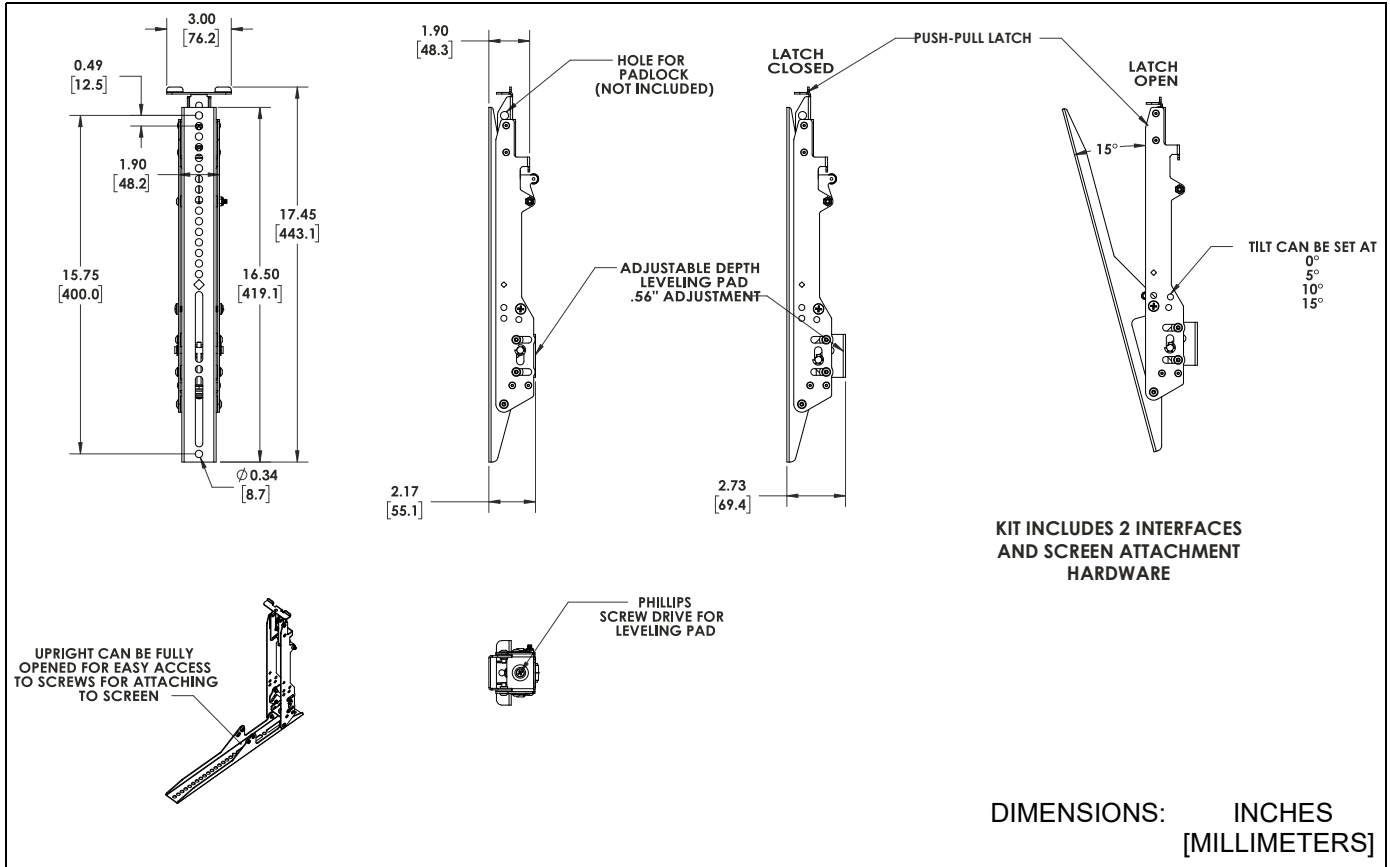

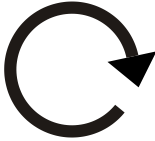

Figure 1

--SAVE THESE INSTRUCTIONS--

**DIMENSIONS**

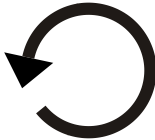

**LEGEND**

	<b>Tighten Fastener</b>		<b>Phillips Screwdriver</b>
	Apretar elemento de fijación		Destornillador Phillips
	Befestigungsteil festziehen		Kreuzschlitzschraubendreher
	Apertar fixador		Chave de fendas Phillips
	Serrare il fissaggio		Cacciavite a stella
	Bevestiging vastdraaien		Kruiskopschroevendraaier
Serrez les fixations	Tournevis à pointe cruciforme		
	<b>Loosen Fastener</b>		
	Aflojar elemento de fijación		
	Befestigungsteil lösen		
	Desapertar fixador		
	Allentare il fissaggio		
	Bevestiging losdraaien		
Desserrez les fixations			

**TOOLS REQUIRED FOR INSTALLATION**



**PARTS**

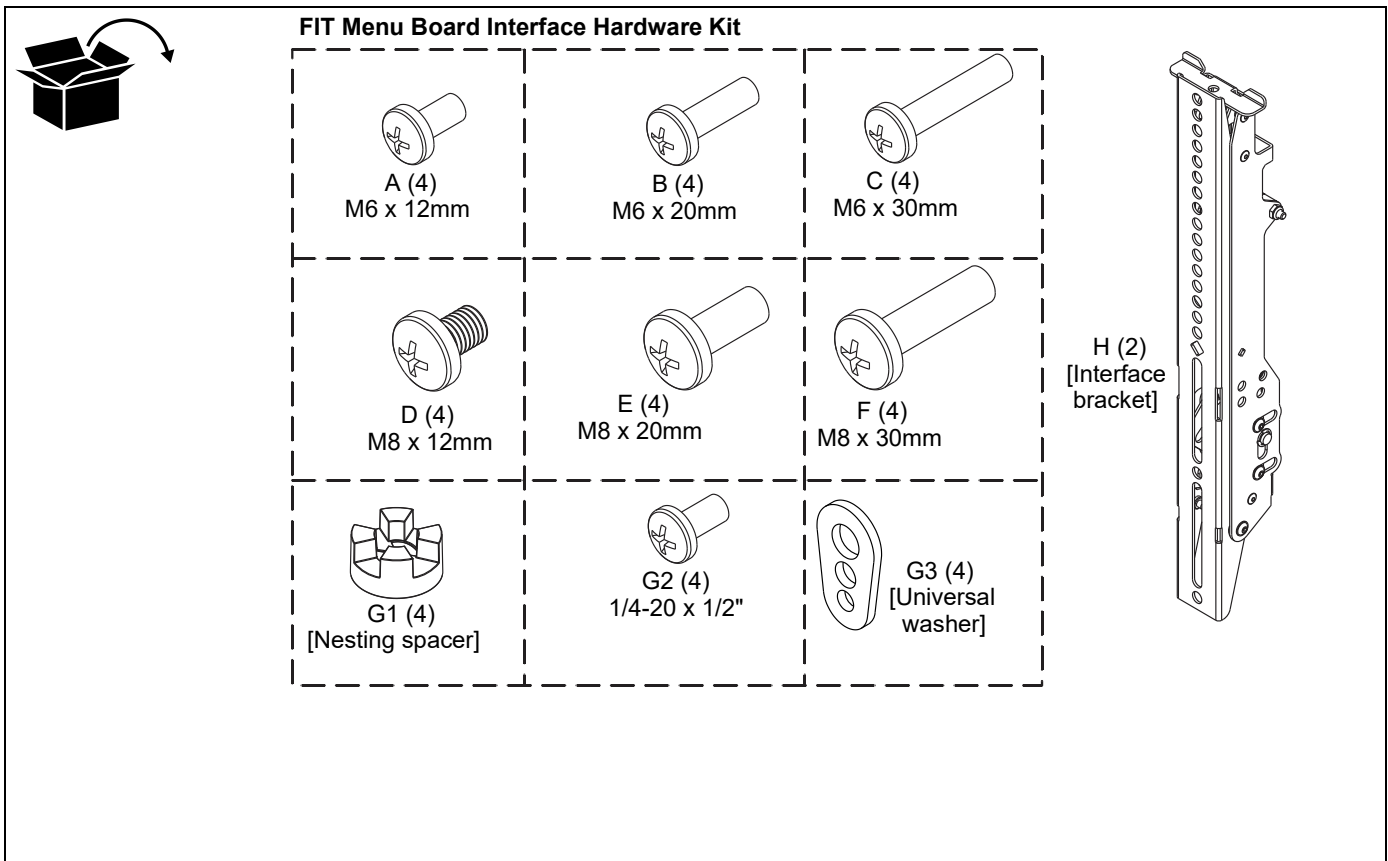

### PREPARING FOR INSTALLATION

1. Ensure the latch on both interface brackets (H) is in the **OPEN** position. (See Figure 2)

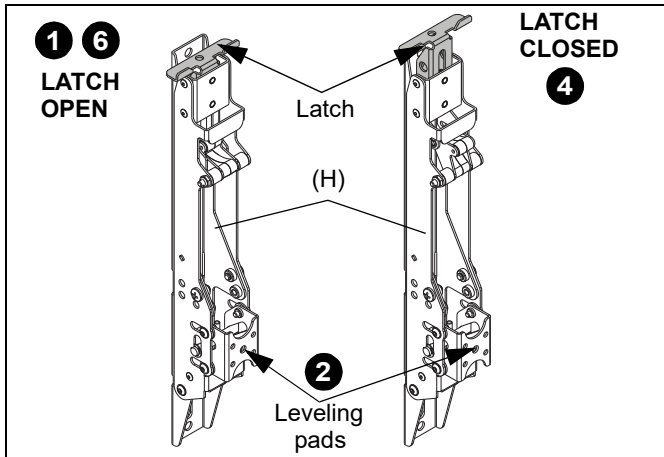

Figure 2

2. Hang interface brackets (H) on the strut channel with the leveling pads located towards the wall. (See Figure 2)

**NOTE:** The interface brackets allow 0° to 15° tilt, and can be locked at 0°, 5°, 10° and 15° tilt.

3. Adjust tilt as required and loosely install one 1/4-20 x 1/2" Phillips head screw (G2) per bracket to temporarily hold the tilt. (See Figure 3)
4. Raise latch on interface brackets to **CLOSED** position. (See Figure 2)

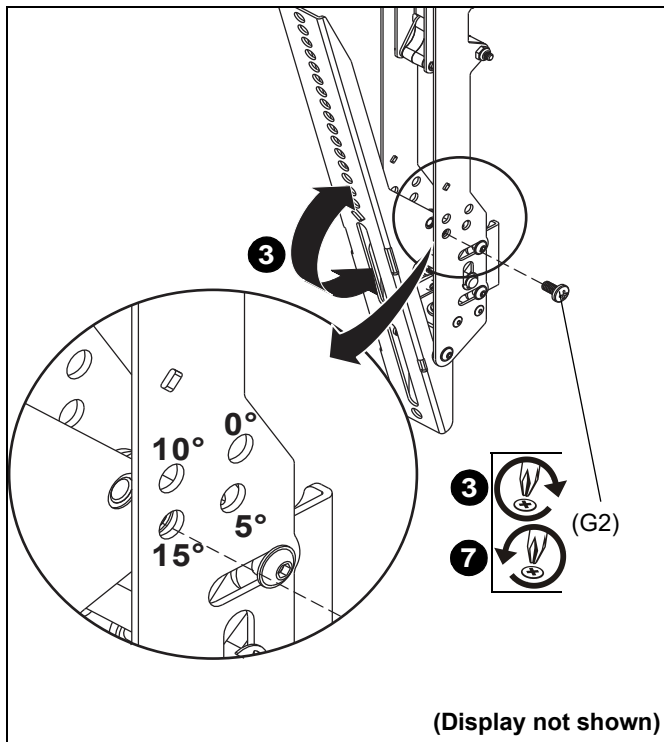

Figure 3

5. Adjust each interface bracket (using the Phillips adjustment screw at bottom of interface bracket) until the leveling pad is flat against the wall. (See Figure 4)

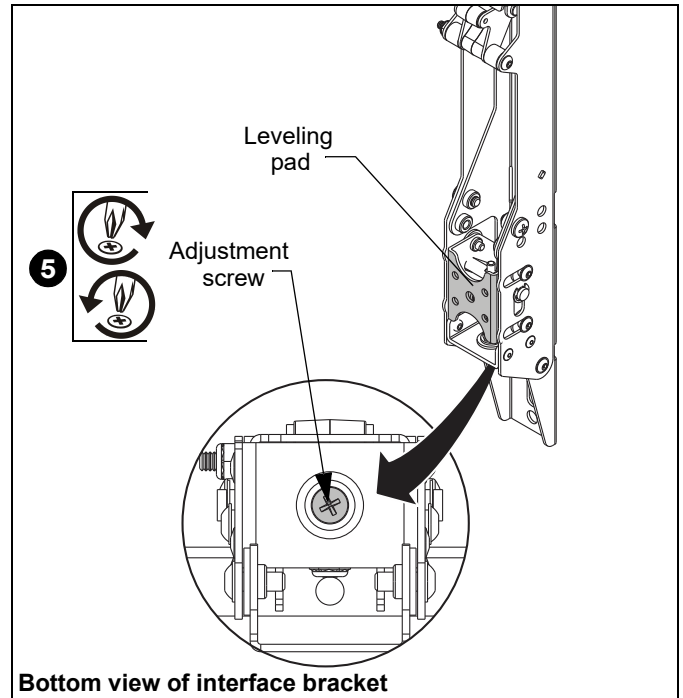

Figure 4

6. Lower interface bracket latches to **OPEN** position and remove interface brackets from strut channel. (See Figure 2)
7. Remove fastener loosely holding tilt which was installed in Step 3. (See Figure 3)

### INSTALL INTERFACE BRACKETS TO DISPLAY

1. Place display face down on a soft, non-abrasive surface.



**WARNING:** IMPROPER INSTALLATION CAN LEAD TO DISPLAY FALLING CAUSING SERIOUS PERSONAL INJURY OR DAMAGE TO EQUIPMENT! Using screws of improper size may damage your display. Properly sized screws will easily and completely thread into display mounting holes. If spacers are required, be sure to use longer screws of the same diameter.

2. Select screw *diameter* by examining hardware (A-F) and comparing with mounting holes on display.
3. Select spacers:
  - Spacers are **NOT** required if mounting holes are not recessed and interface brackets (H) can lay flat against display.
  - Spacers (G1) **ARE** required if mounting holes are recessed, or if protrusions prevent interface brackets (H) from laying flat.

**NOTE:** The nesting spacers (G1) may be used separately, or put two together in different configurations to create different size spacers. (See Figure 5)

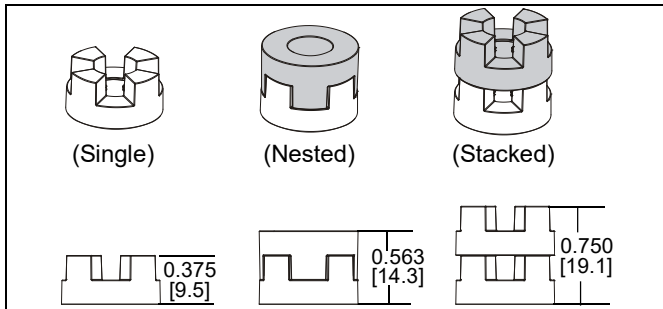

**Figure 5**

4. Select screw length:

- By hand, insert **SHORTEST** length screw of selected diameter (A or D) through universal washer (G3--if required), bracket (H), spacer (G1--if required), into display mounting hole. Do **NOT** thread screw into hole at this time.

**IMPORTANT ! :** The M8 screws do **NOT** require a washer. Use the universal washer (G3) **ONLY** with the M6 screws.

- Proper screw length requires base of screw head to protrude above flat washer a *distance equal to or greater than the screw diameter*. If screw length is inadequate, select longer screw. Select *shortest* screw which will protrude the required distance.

5. Align the center of the interface brackets (H) with center of screen. (See Figure 6)

**NOTE:** The diamond-shape hole in the bracket corresponds to the center of the mount. (See Figure 6)

6. Use selected screws (A-F), washers (G3--if required), and spacers (G1--if required), to connect interface brackets (H) to back of display. (See Figure 6)

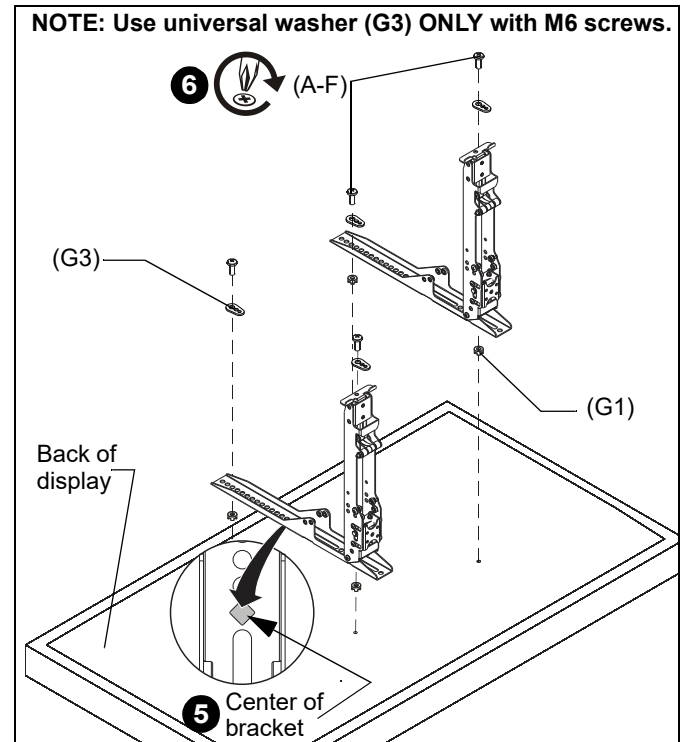

**Figure 6**

## INSTALLING DISPLAY TO STRUT CHANNEL

**IMPORTANT ! :** The RMB400 is designed to be mounted to a strut channel (not included--characteristics are listed on page 2) which has been mounted to one of the following types of walls:

- a bare 8" thick solid concrete wall. Fasteners (not included) must be placed a minimum of 16" and a maximum of 24" apart **AND** within 9" of each end of the strut channel.
- a 5/8" minimum thickness plywood-backed, steel stud wall covered with drywall having a maximum thickness of 5/8". Fasteners (not included) must be placed a maximum of 8" apart **AND** in last slots on each end of the strut channel.
- a 2" x 4" wood stud wall covered with drywall having a maximum thickness of 5/8". Fasteners (not included) must be placed a minimum of 16" and a maximum of 24" apart **AND** within 9" of each end of the strut channel.

1. Install the strut channel (not included) in the desired location following fastener locating information (above).

## ATTACH DISPLAYS TO STRUT CHANNEL



**WARNING:** IMPROPER INSTALLATION CAN LEAD TO DISPLAY FALLING CAUSING SERIOUS PERSONAL INJURY OR DAMAGE TO EQUIPMENT! The displays must be located approximately evenly across the length of the strut channel.

1. Ensure that the latch mechanisms on interface brackets (H) are already in the OPEN position.
2. While supporting both sides of display, lower display onto strut channel hooking top of interface brackets into lower channel of strut channel. (See Figure 7)

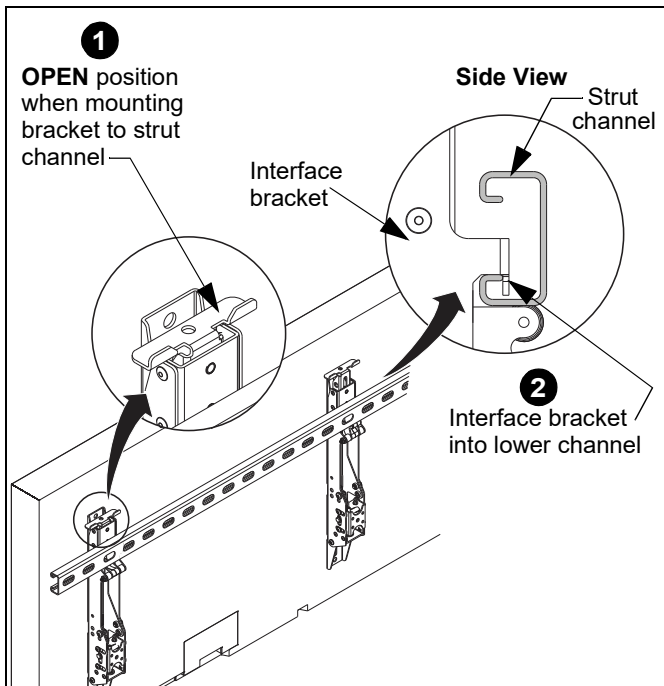
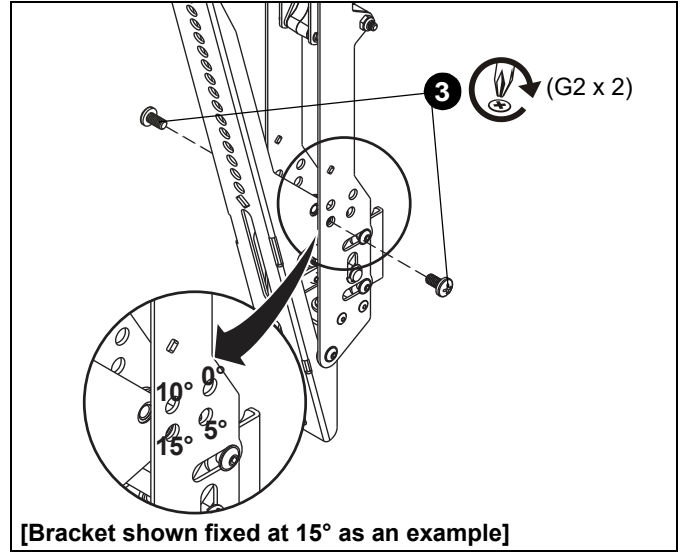

Figure 7



**CAUTION:** **ALWAYS** keep a small distance between screens when making adjustments! Damage to screens possible if placed too close together.

3. Adjust tilt on interface brackets as determined in Step 3 of the **Preparing for Installation** section, and fasten in place using two 1/4-20 x 1/2" Phillips head screws (G2) per interface bracket. (See Figure 8)
4. Check the plumb across the displays, and adjust the leveling pads as necessary, using the adjustment screw at the bottom of the interface brackets. (See Figure 4)



[Bracket shown fixed at 15° as an example]

Figure 8

5. Raise the latch mechanism on both interface brackets to **CLOSED** position to lock interface brackets in place. (See Figure 9)

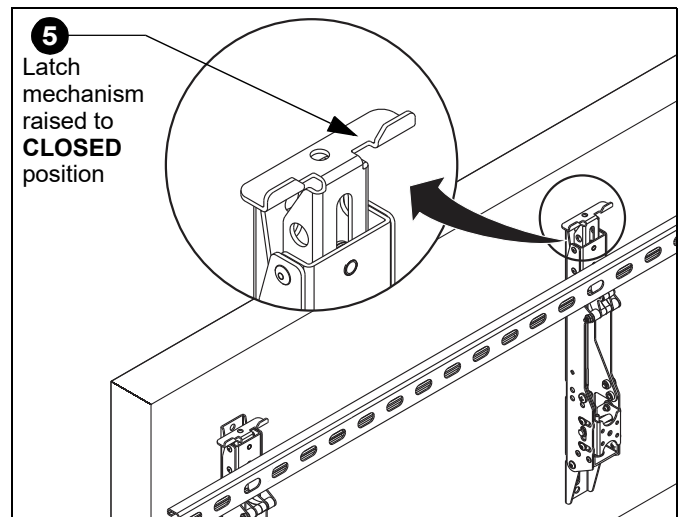

Figure 9

**IMPORTANT ! :** If the interface brackets are locked at 0°, a lock (not included) with an extended shackle is required. (See Figure 10)

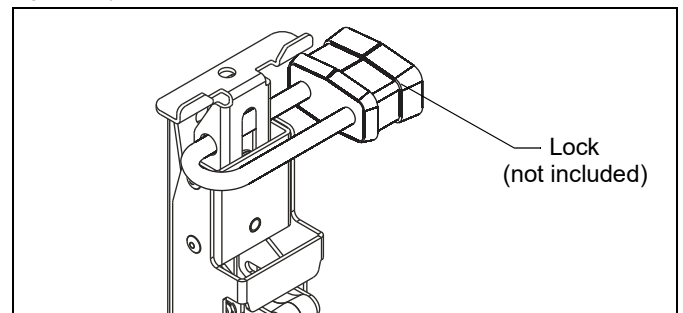

Figure 10



Our Mounts. **Your Vision.**

Chief, a products division of  
Milestone AV Technologies

8800-003063 Rev01  
©2018 Milestone AV Technologies  
[www.milestone.com](http://www.milestone.com)  
06/18

<b>USA/International</b>	<b>A</b> 6436 City West Parkway, Eden Prairie, MN 55344 <b>P</b> 800.582.6480 / 952.225.6000 <b>F</b> 877.894.6918 / 952.894.6918
<b>Europe</b>	<b>A</b> Franklinstraat 14, 6003 DK Weert, Netherlands <b>P</b> +31 (0) 495 580 852 <b>F</b> +31 (0) 495 580 845
<b>Asia Pacific</b>	<b>A</b> Office No. 918 on 9/F, Shatin Galleria 18-24 Shan Mei Street Fotan, Shatin, Hong Kong <b>P</b> 852 2145 4099 <b>F</b> 852 2145 4477

