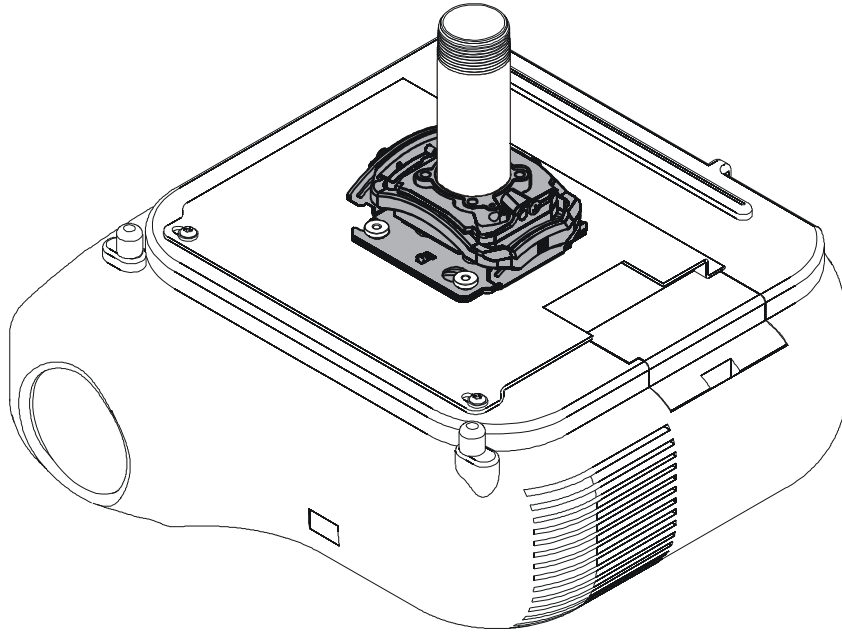

INSTALLATION INSTRUCTIONS

Touchboards

205 Westwood Ave, Long Branch, NJ 07740

Phone: 866-94 BOARDS (26273) / (732)-222-1511

Fax: (732)-222-7088 | E-mail: sales@touchboards.com



RSM Elite Series Projector Mounts

CHIEF[®]

Our Mounts. Your Vision.

RSM A-D

DISCLAIMER

Milestone AV Technologies, and its affiliated corporations and subsidiaries (collectively, "Milestone"), intend to make this manual accurate and complete. However, Milestone makes no claim that the information contained herein covers all details, conditions or variations, nor does it provide for every possible contingency in connection with the installation or use of this product. The information contained in this document is subject to change without notice or obligation of any kind. Milestone makes no representation of warranty, expressed or implied, regarding the information contained herein. Milestone assumes no responsibility for accuracy, completeness or sufficiency of the information contained in this document.

Chief® is a registered trademark of Milestone AV Technologies. All rights reserved.



IMPORTANT SAFETY INSTRUCTIONS



WARNING: A WARNING alerts you to the possibility of serious injury or death if you do not follow the instructions.



CAUTION: A CAUTION alerts you to the possibility of damage or destruction of equipment if you do not follow the corresponding instructions.



WARNING: Failure to read, thoroughly understand, and follow all instructions can result in serious personal injury, damage to equipment, or voiding of factory warranty! It is the installer's responsibility to make sure all components are properly assembled and installed using the instructions provided.



WARNING: Failure to provide adequate structural strength for this component can result in serious personal injury or damage to equipment! It is the installer's responsibility to make sure the structure to which this component is attached can support five times the combined weight of all equipment. Reinforce the structure as required before installing the component.



WARNING: Exceeding the weight capacity can result in serious personal injury or damage to equipment! It is the installer's responsibility to make sure the combined weight of all components attached to the RSM does not exceed 25 lbs (11.34 kg).

- The weight capacity of the RSM may be LIMITED to the lowest weight capacity of any other components located between the RSM and the supporting structure!



WARNING: Use this mounting system only for its intended use as described in these instructions. Do not use attachments not recommended by the manufacturer.



WARNING: Never operate this mounting system if it is damaged. Return the mounting system to a service center for examination and repair.



WARNING: Do not use this product outdoors.

IMPORTANT ! : The RSM mounts are designed to be:

- mounted to a 1-1/2" NPT or NPSM following ANSI/ ASME B1.20.1 (Schedule 40, 0.154" minimum thickness aluminum- ASTM B221) threaded extension column.
- mounted to double 2" x 4" wood stud cross bracing (1-1/2" on center) between two 2" x 4" ceiling joists; with a maximum drywall covering of 5/8".
- mounted to a concrete ceiling with a minimum thickness of 8" and a maximum drywall covering of 5/8"; or
- suspended from four 1/4" diameter (minimum) Grade 2 or better threaded rods (not included) which are secured to unistrut, angle or channel assembly overhead structural members (trusses or I-beams) by Grade 2 or better 1/4" channel nuts (not included).







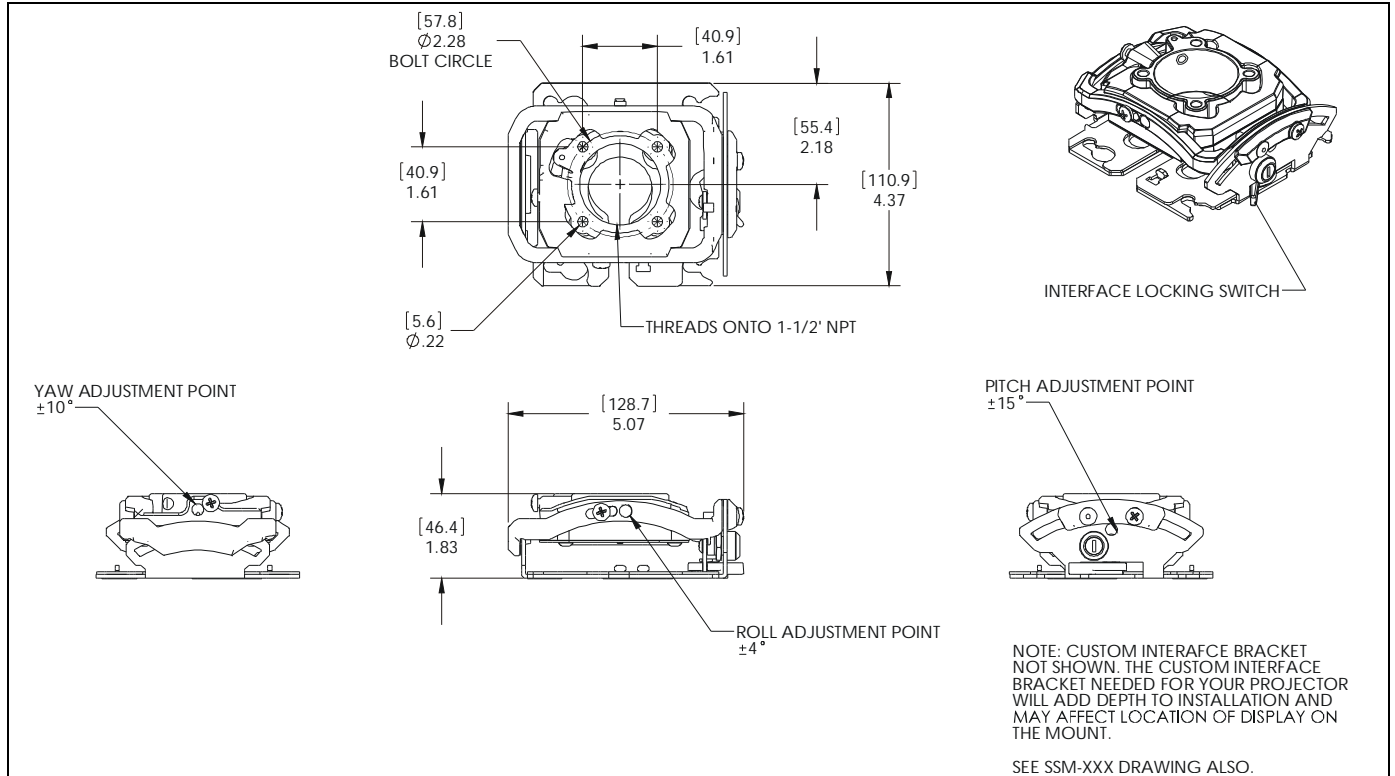



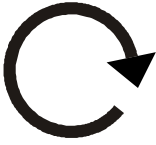

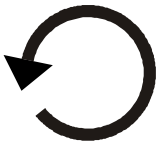
NOTE: RSM Series may be used with Listed Chief models WM110S, WM120S, WM130S, WM210S, WM220S, WM230S, WM240S, WM210SI, WM220SI, WM230SI, WM240SI and SL220 (not included).

--SAVE THESE INSTRUCTIONS--



DIMENSIONS



LEGEND

	Tighten Fastener Serrez les fixations Serrare il fissaggio Befestigungsteil festziehen Apretar elemento de fijación Bevestiging vastdraaien Apertar fixador		Pencil Mark Marquage au crayon Segno a matita Stiftmarkierung Marcar con lápiz Potloodmerkteken Marcar com lápis
	Loosen Fastener Desserrez les fixations Allentare il fissaggio Befestigungsteil lösen Aflojar elemento de fijación Bevestiging losdraaien Desapertar fixador		Drill Hole Percez un trou Praticare un foro Bohrloch Perforar Gat boren Fazer furo
	Phillips Screwdriver Tournevis à pointe cruciforme Cacciavite a stella Kreuzschlitzschraubendreher Destornillador Phillips Kruiskopschroevendraaier Chave de fendas Phillips		Adjust Ajuster Regolare Einstellen Ajustar Afstellen Ajustar
	Hex-Head Wrench Clé à tête hexagonale Chiave esagonale Sechskantschlüssel Llave de cabeza hexagonal Zeskantsleutel Chave de cabeça sextavada		Remove Retirez Rimuovere Entfernen Quitar Verwijderen Remover
	Open-Ended Wrench Clé à fourche Chiave a punte aperte Gabelschlüssel Llave de boca Steeksleutel Chave de bocas		Optional En option Opzionale Optional Opcional Optie Opcional
	By Hand À la main A mano Von Hand A mano Met de hand Com a mão		Security Wrench Clé de sécurité Chiave di sicurezza Sicherheitsschlüssel Llave de seguridad Veiligheidsleutel Chave de segurança

LEGEND

	Hammer		Target of Projector
	Martillo		Punto de enfoque del proyector
	Hammer		Ziel des Projektors
	Martelo		Mira do projector
	Martello		Punto di proiezione
	Hamer		Doel van de projector
	Marteau		Cible du projecteur

TOOLS REQUIRED FOR INSTALLATION

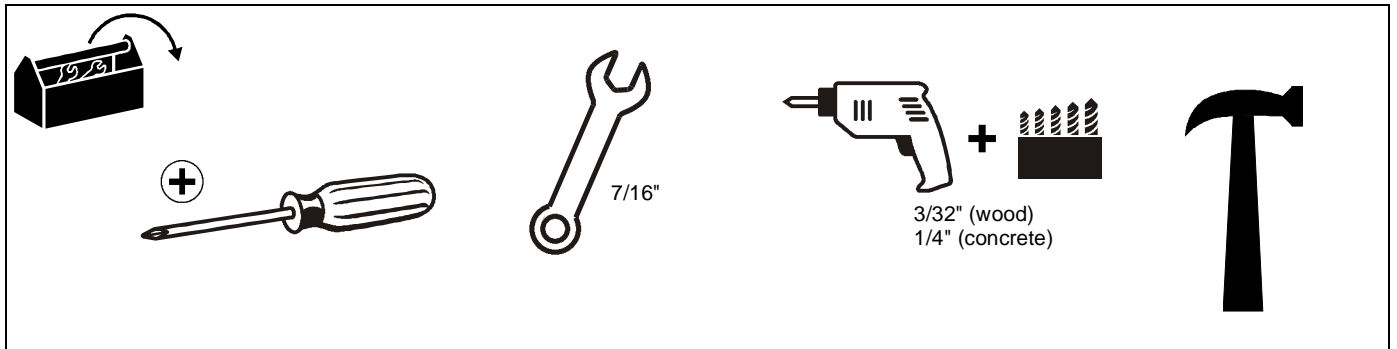

PARTS

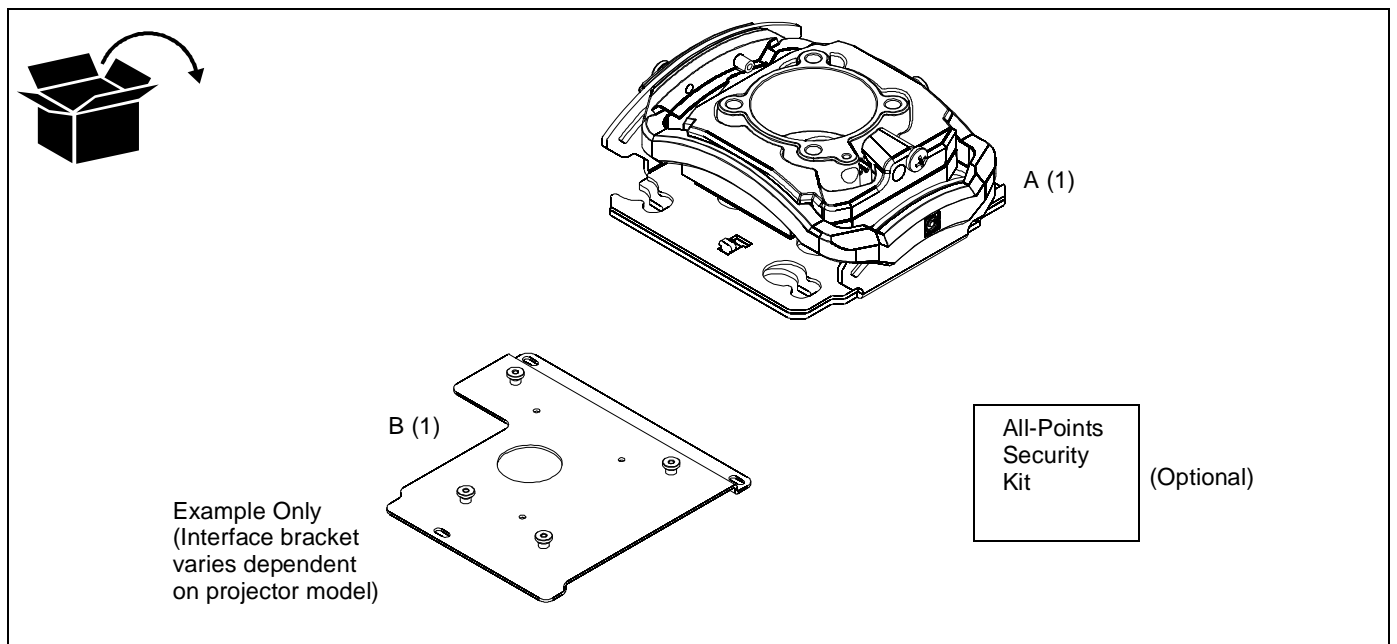

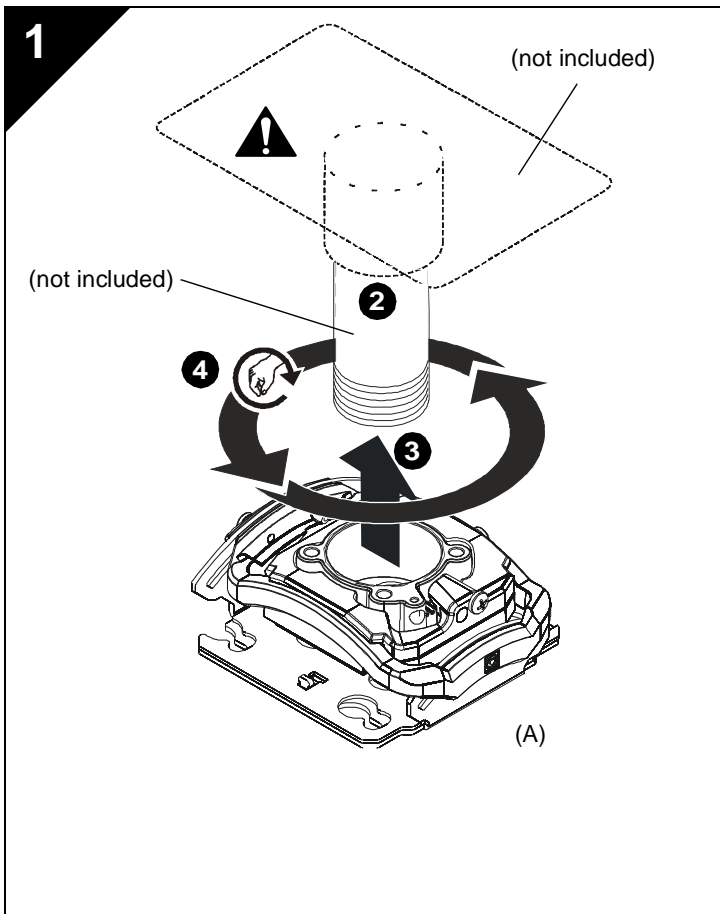

RSM INSTALLATION

NOTE: Models RSM-A/RSM-B/RSM-C/RSM-D are identical EXCEPT each provides a different keyed lock.

Threaded Pipe Installation

1. Carefully determine required mounting location. **IMPORTANT ! :** This will require knowing the lens to screen distance. See projector specifications for details on determining this distance.
2. Install 1-1/2" NPT or NPSM following ANSI/ASME B1.20.1 (Schedule 40, 0.154" minimum thickness aluminum - ASTM B221) threaded extension column (not included) into threaded collar until tight, with a minimum of four threads engaged.

⚠ WARNING: IMPROPER INSTALLATION CAN RESULT IN SERIOUS PERSONAL INJURY OR DAMAGE TO EQUIPMENT! Structural members **MUST** be capable of supporting five times the combined weight of all equipment being mounted.

3. Align RSM with end of NPT pipe.
4. Thread RSM up onto pipe by turning until hand tight.

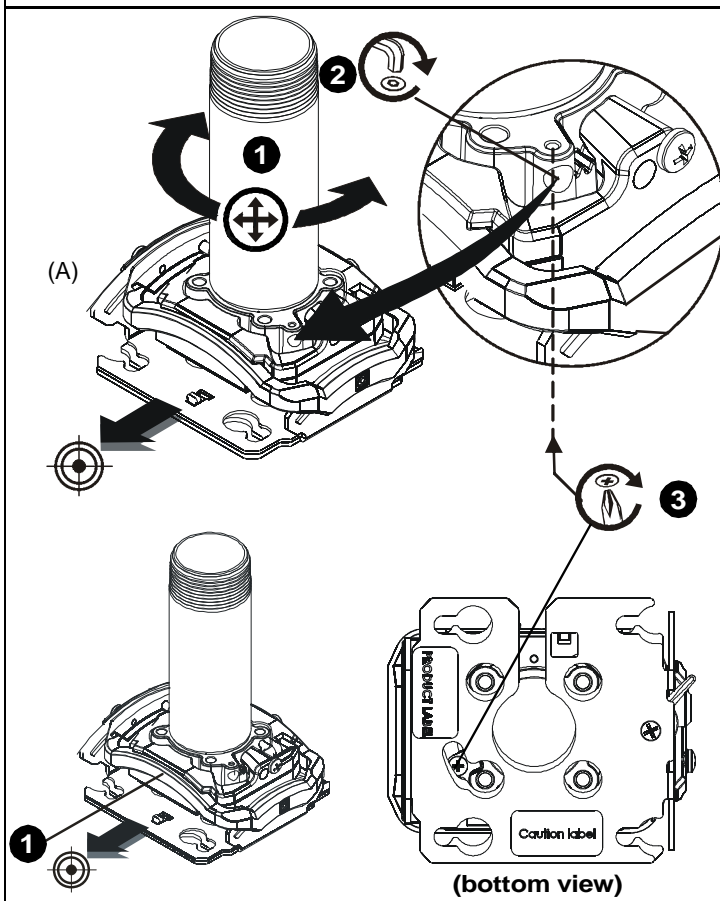

Rough Alignment of RSM

1. Turn RSM clockwise or counter-clockwise until front of mount is facing target.
2. Secure RSM to pipe by turning set screw until tight.

⚠ CAUTION: DO NOT OVERTIGHTEN! Over tightening of setscrew can damage threads on pipe.

3. Turn security screw using a Phillips screwdriver until set screw cannot be seen through access hole in RSM.

INSTALLATION

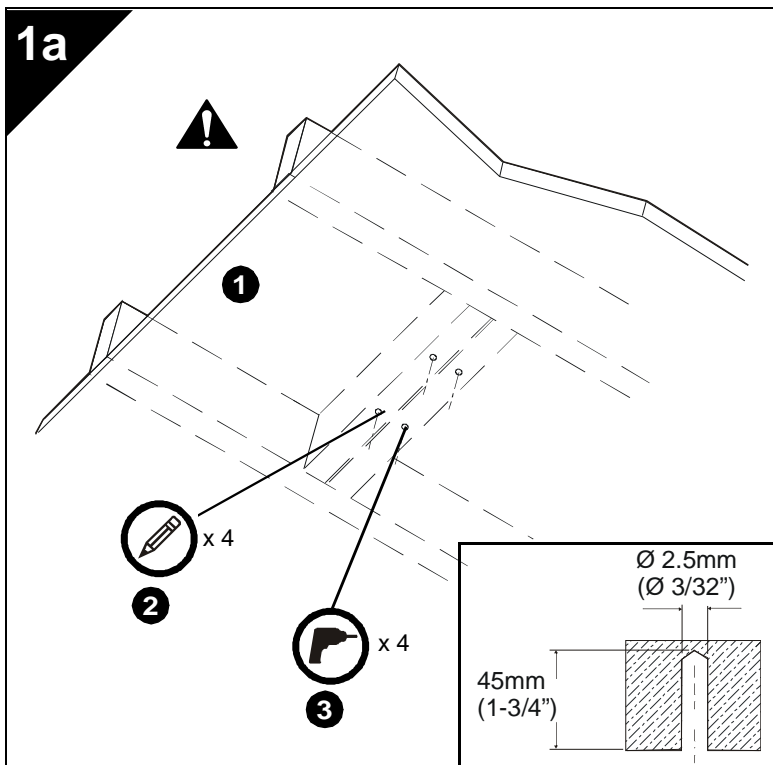

Wood Stud Installation

1. Carefully determine required mounting location.

IMPORTANT ! : This will require knowing the lens to screen distance. See projector specifications for details on determining this distance.



WARNING: IMPROPER INSTALLATION CAN RESULT IN SERIOUS PERSONAL INJURY OR DAMAGE TO EQUIPMENT! Structural members **MUST** be capable of supporting five times the combined weight of all equipment being mounted.

IMPORTANT ! : The RSM mounts are designed to be mounted to double 2" x 4" wood stud cross bracing (1-1/2" on center) between two ceiling joists; with a maximum drywall covering of 5/8".

2. Using the RSM as a guide, mark four mounting hole locations with a pencil or similar tool. Hole locations must be centered on 2" x 4" cross braces.

3. Drill four 3/32" (2.5mm) dia. pilot holes to a depth of 1-3/4" (45mm) deep.

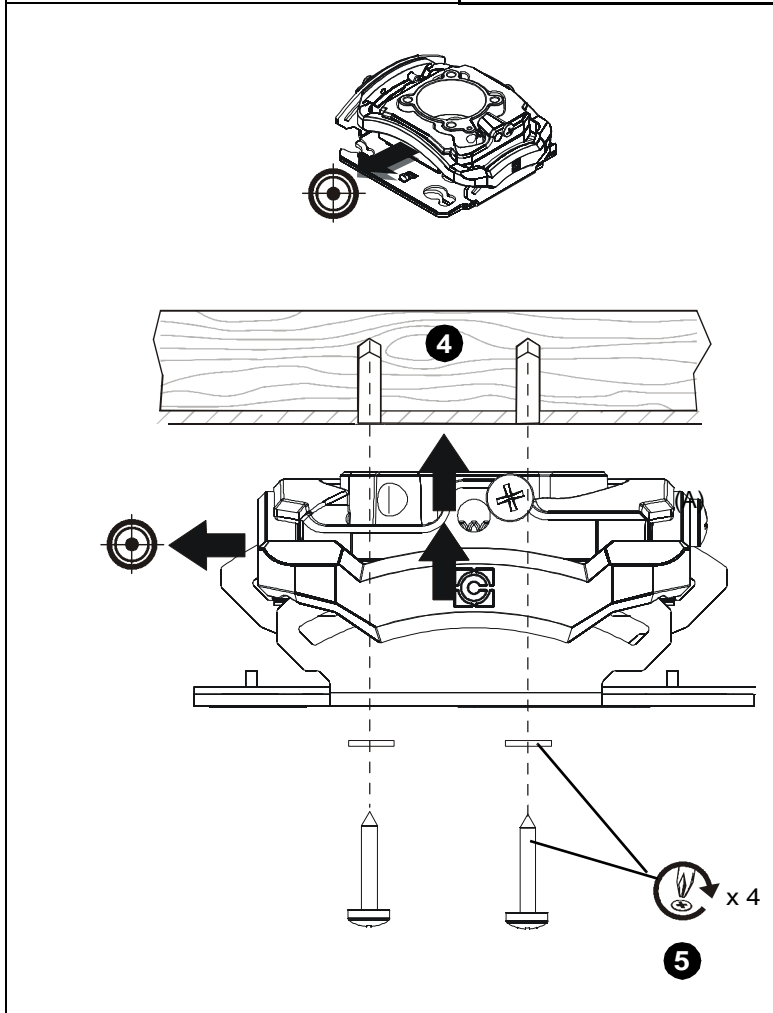

4. Align four mounting holes in RSM with four pilot holes.

IMPORTANT ! : Make sure mount is properly oriented towards target before securing to structure.

5. Secure RSM to structure using four #10 flat washers and four #10 x 3" Phillips head wood screws (not included).

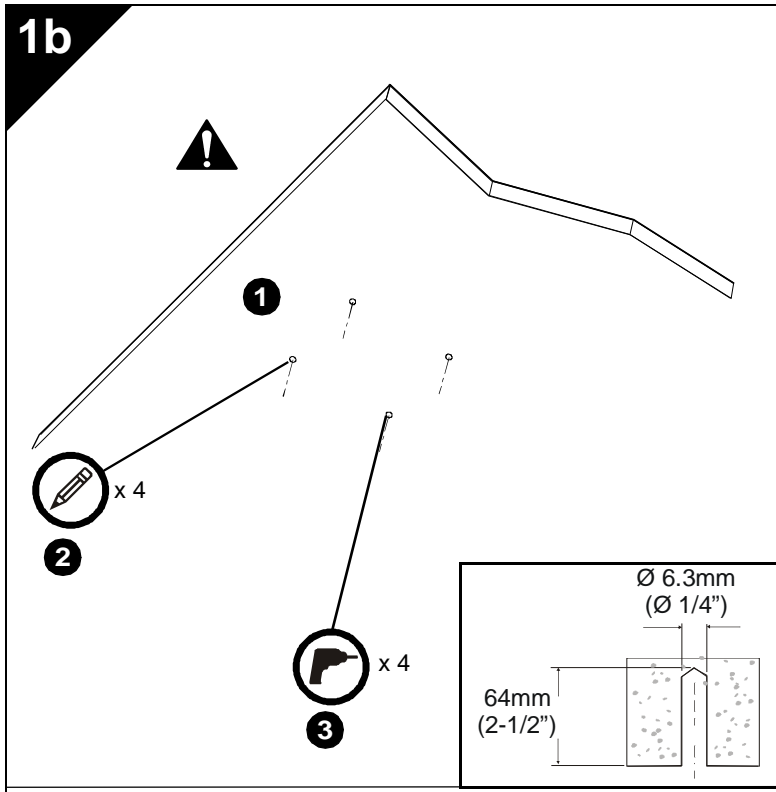

Concrete Installation

1. Determine mounting location.



WARNING: The RSM is designed to be mounted to a concrete ceiling with a minimum thickness of 8" and a maximum drywall covering of 5/8".



WARNING: IMPROPER INSTALLATION CAN RESULT IN SERIOUS PERSONAL INJURY OR DAMAGE TO EQUIPMENT! Structural members **MUST** be capable of supporting five times the combined weight of all equipment being mounted.

2. Using the RSM as a guide, mark four mounting hole locations on ceiling using a pencil or similar tool.
3. Drill four 1/4" (6.3mm) dia. pilot holes to a depth of 2-1/2" (64mm) deep.

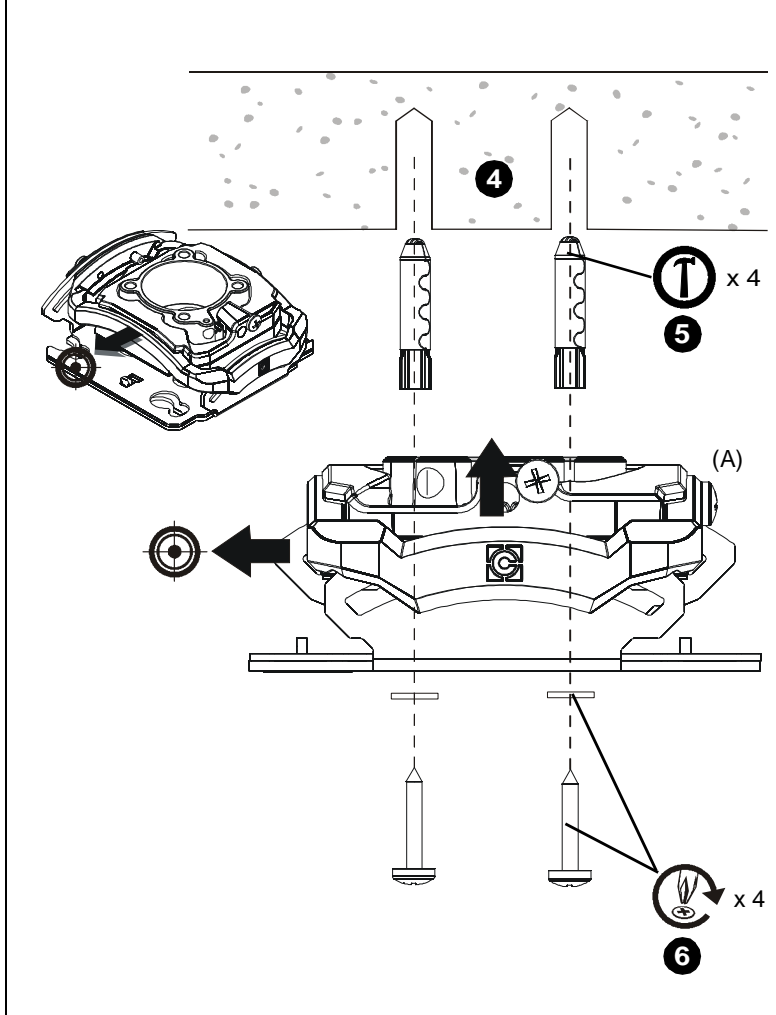

4. Align four mounting holes in RSM with four pilot holes.

IMPORTANT ! : Make sure mount is properly oriented towards target before securing to structure.



WARNING: Anchors (not provided) must be installed into structurally sound solid concrete. Installation into hollow concrete block, mortar, or concrete that exhibits cracking, spalling, or other defects may result in failure of anchor and serious personal injury or damage to equipment.

5. Install four 3/8" x 2-1/4" Grade 2 concrete anchors (not included) by inserting into pilot holes and pounding in until flush with mounting surface.
6. Secure RSM to structure using four #10 flat washers and four #10 x 3" Phillips head wood screws (not included).

1c

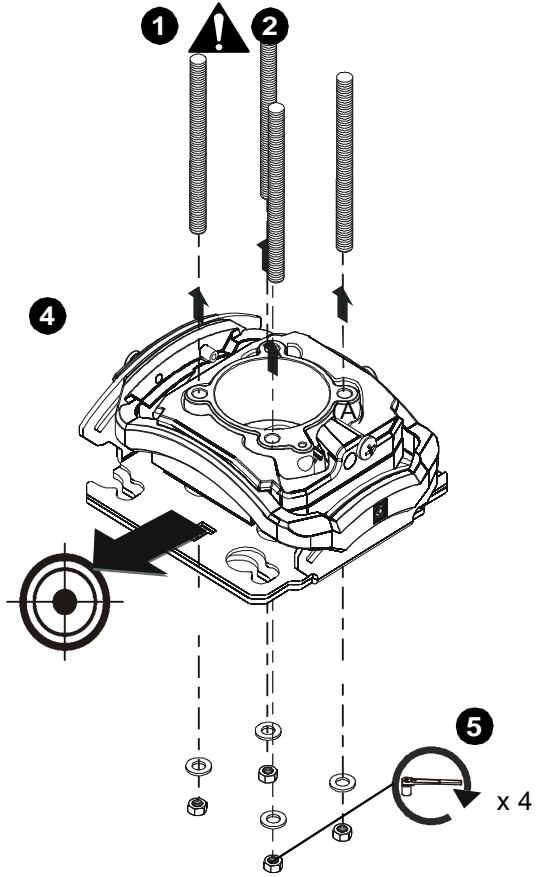

Threaded Rod Installation

The RSM must be suspended from four 1/4" diameter (minimum) Grade 2 or better threaded rods (not included) which are secured to unistrut, angle or channel assembly overhead structural members (trusses or I-beams) by Grade 2 or better 1/4" channel nuts (not included).



WARNING: IMPROPER INSTALLATION CAN RESULT IN SERIOUS PERSONAL INJURY OR DAMAGE TO EQUIPMENT! Structural members **MUST** be capable of supporting five times the combined weight of all equipment being mounted.

1. Carefully determine required mount position.
IMPORTANT ! : This will require knowing the lens to screen distance. See projector specifications for determining this distance.

NOTE: Threaded rod and installation hardware not included.

2. Secure one end of the threaded rod to the structural member.
3. Install four #10-24 jam nuts on each threaded rod.
4. Install the RSM on the threaded rod.

NOTE: Hole in the RSM allows socket wrench access without unit disassembly.

2

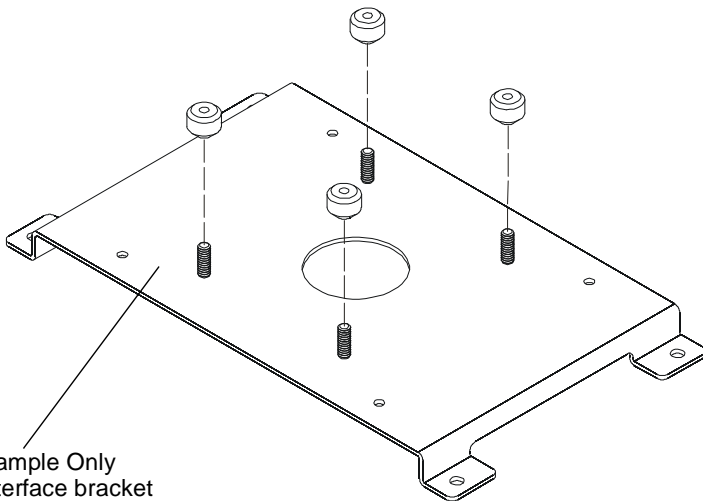

Example Only
(Interface bracket varies dependent on projector model)

PROJECTOR INSTALLATION

IMPORTANT ! : Model RSM uses optional Chief "SSM" Series interface brackets. (See Parts drawing.)

Install Interface Bracket

1. Partially thread thumb nuts onto Phillips screws until screw end is visible in top of thumb screw.

IMPORTANT ! : DO NOT fully tighten thumb screws at this time.

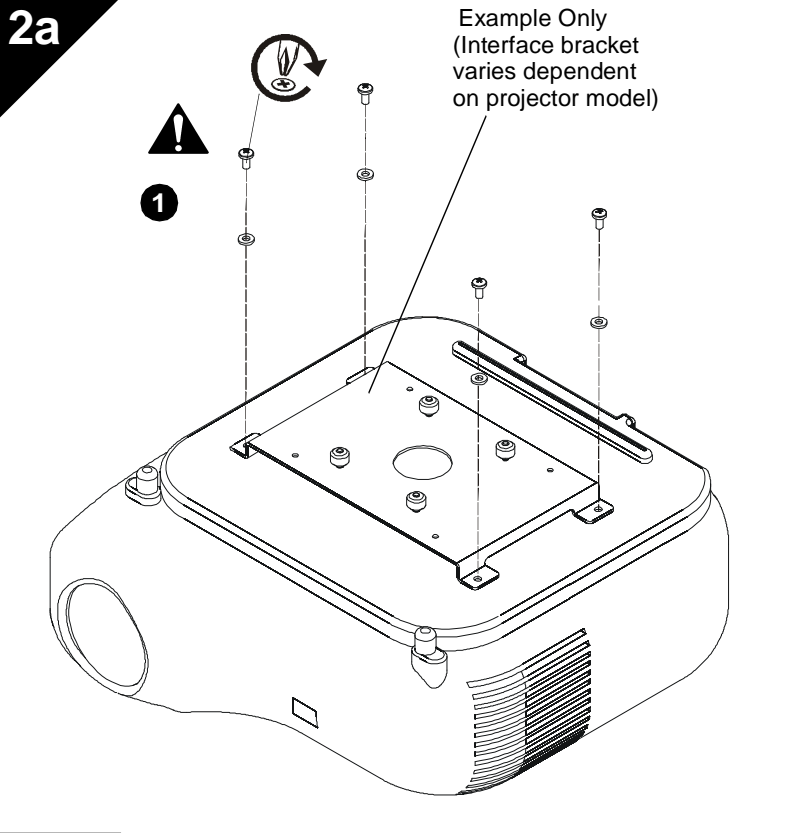

⚠ WARNING: IMPROPER INSTALLATION CAN LEAD TO PROJECTOR FALLING RESULTING IN SERIOUS PERSONAL INJURY OR DAMAGE TO EQUIPMENT. DO NOT substitute hardware. Use only the hardware provided by the manufacturer.

1. Secure interface bracket to mount using installation instructions and hardware provided with interface bracket.

NOTE: Interface brackets can be installed using the optional All-Points Security Kit included with the SSM mounting solutions.

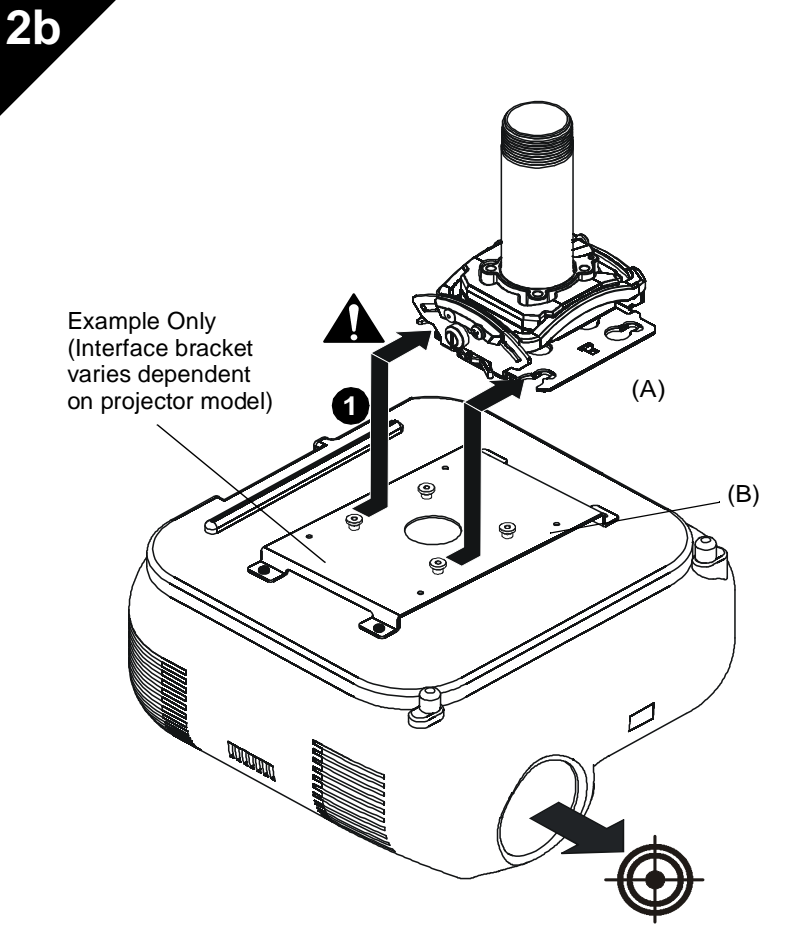

Install Projector With Interface Bracket

1. Orient projector with interface bracket as shown in figure 2b at left.
2. Lift projector so that screws with thumb nuts are aligned with mounting slots in mount base.
3. Slide projector with mounting bracket onto mounting slots in mount base until screws are seated against the back of mounting slots. See figure 2b and 2c.

⚠ WARNING: IMPROPER INSTALLATION CAN LEAD TO PROJECTOR FALLING RESULTING IN SERIOUS PERSONAL INJURY OR DAMAGE TO EQUIPMENT. Make certain mounting slots in mount base slide under thumb screws and that screws are seated in the back of slots.

2c

Example Only
(Interface bracket
varies dependent on
projector model)

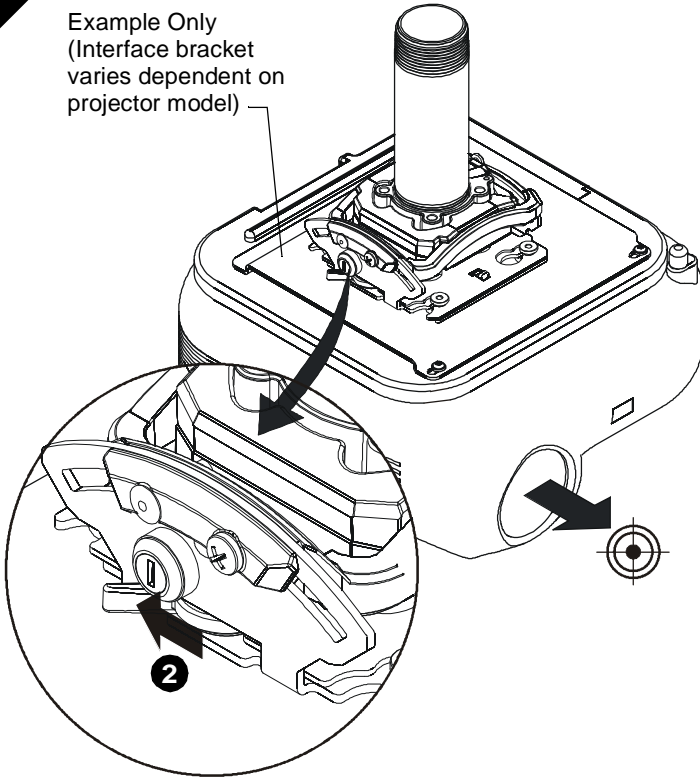

Securing Projector with Interface Bracket to Model RSM Mount



WARNING: IMPROPER INSTALLATION CAN LEAD TO PROJECTOR FALLING RESULTING IN SERIOUS PERSONAL INJURY OR DAMAGE TO EQUIPMENT. Make certain mounting slots in mount base slide under thumb screws and that screws are seated in the back of slots.

1. Verify mounting screws are properly seated in mounting slots in mount base.
2. Move locking lever to "Locked" position as shown in figure 2c at left.
3. Insert key into lock and turn to secure projector to mount.

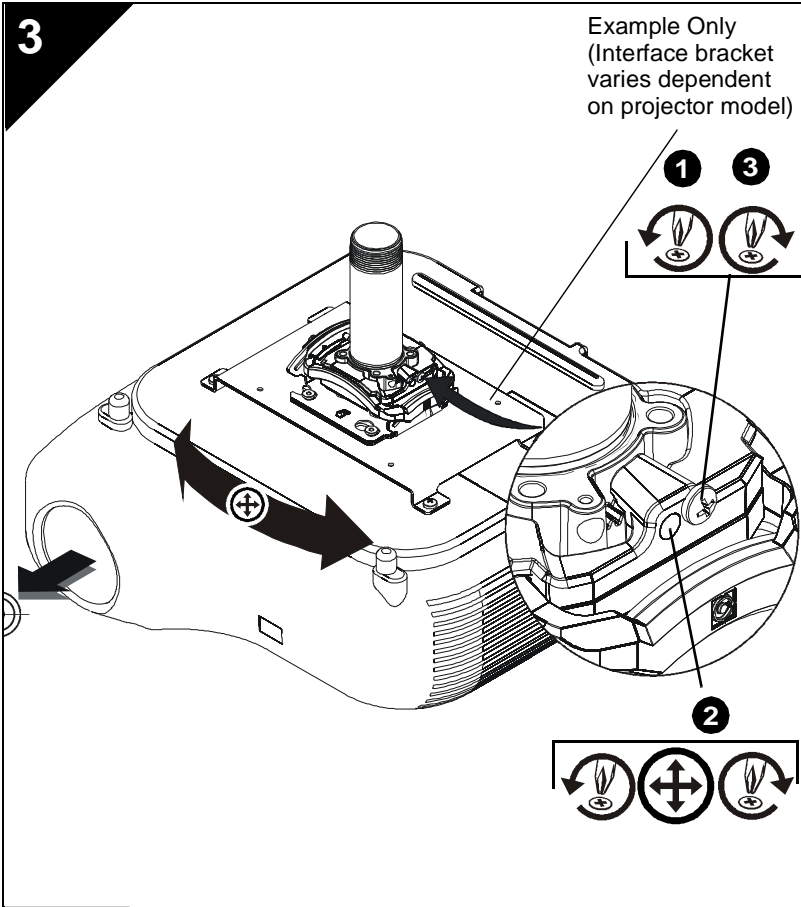

ADJUSTMENTS

YAW Adjustment

1. Loosen YAW adjustment locking screw using a #2 Phillips screwdriver.
2. Turn YAW micro-adjustment screw right or left using a #2 Phillips screwdriver until image is properly aligned on target.
3. Tighten YAW adjustment locking screw using a #2 Phillips screwdriver.

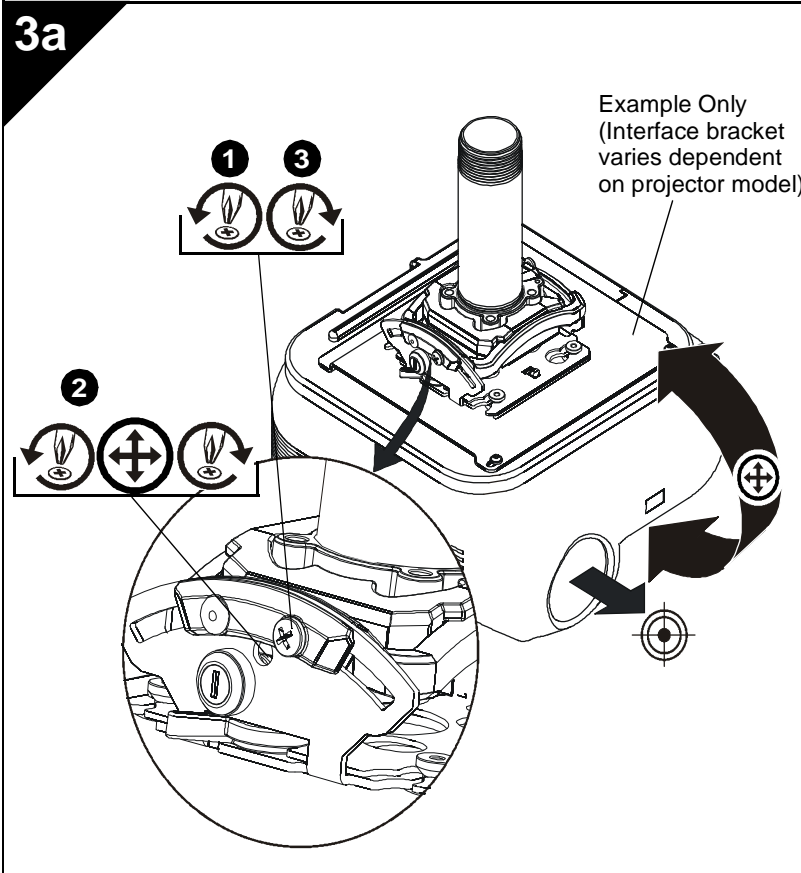

Pitch Adjustment

1. Loosen PITCH adjustment locking screw using a #2 Phillips screwdriver.
2. Turn PITCH micro-adjustment screw right or left using a #2 Phillips screwdriver until image is properly aligned on target.
3. Tighten PITCH adjustment locking screw using a #2 Phillips screwdriver.

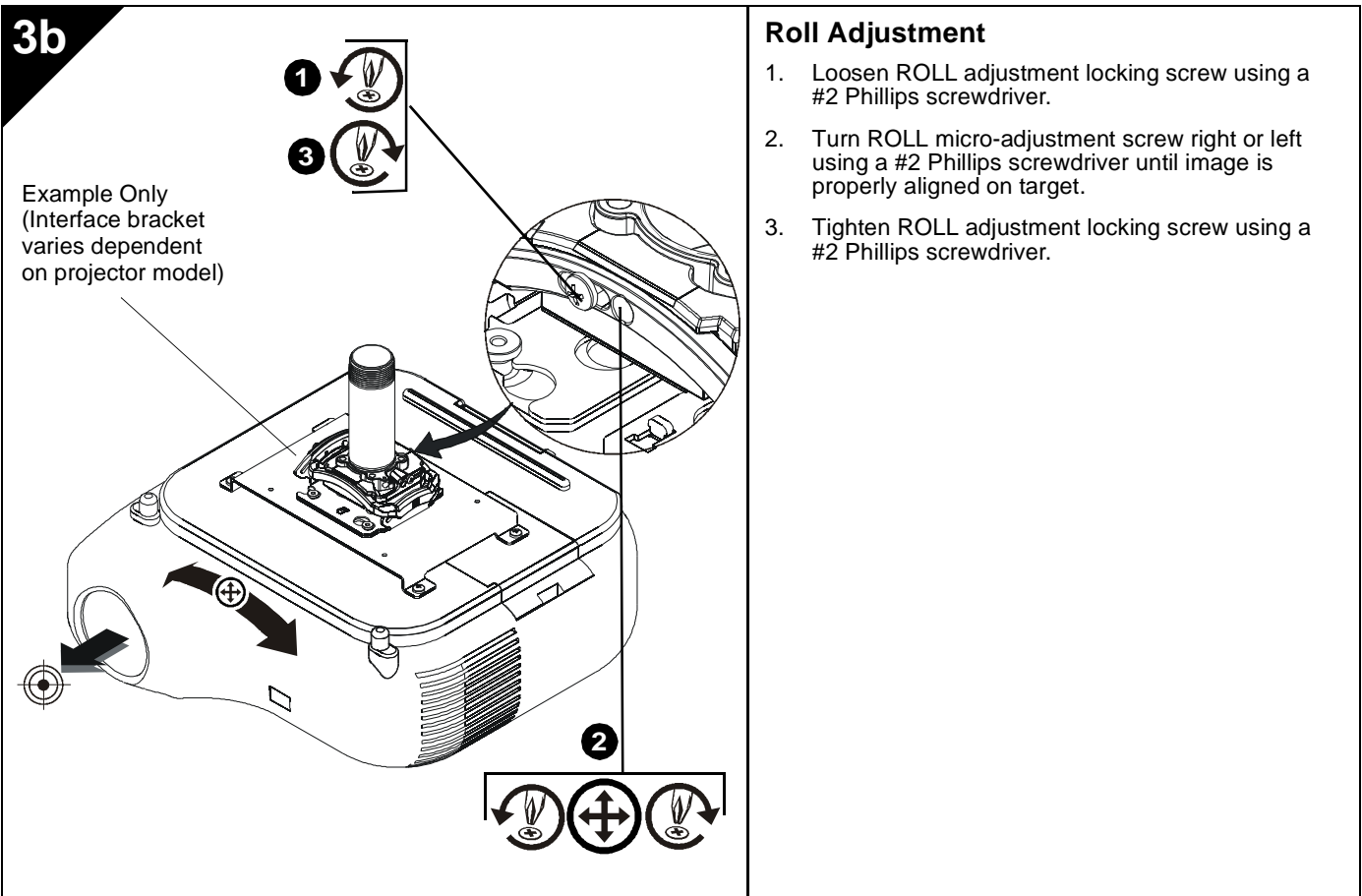



Our Mounts. **Your Vision.**

Chief, a products division of
Milestone AV Technologies

8800-002644 Rev01
©2014 Milestone AV Technologies
www.chiefmfg.com
11/14

USA/International	A 6436 City West Parkway, Eden Prairie, MN 55344 P 800.582.6480 / 952.225.6000 F 877.894.6918 / 952.894.6918
Europe	A Franklinstraat 14, 6003 DK Weert, Netherlands P +31 (0) 495 580 852 F +31 (0) 495 580 845
Asia Pacific	A Office No. 918 on 9/F, Shatin Galleria 18-24 Shan Mei Street Fotan, Shatin, Hong Kong P 852 2145 4099 F 852 2145 4477

