

REVISION HISTORY OF:			
REV	DESCRIPTION OF CHANGE	BY	REV DATE
01	INITIAL RELEASE	ELH	2018/04/13
02	REMOVE "LASER CARVE" NOTE OF SHEET 4	ELH	2018/10/18

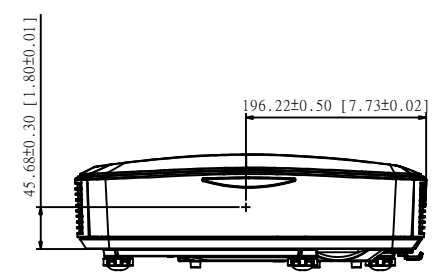

CENTER OF GRAVITY

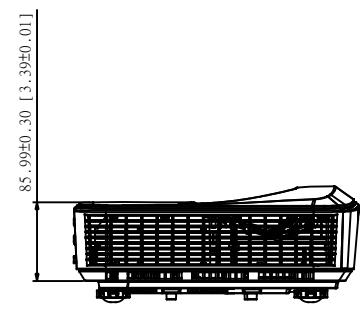
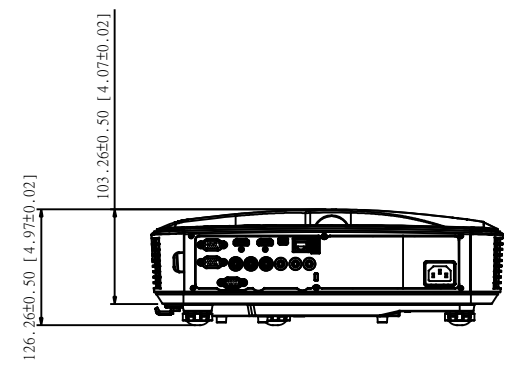
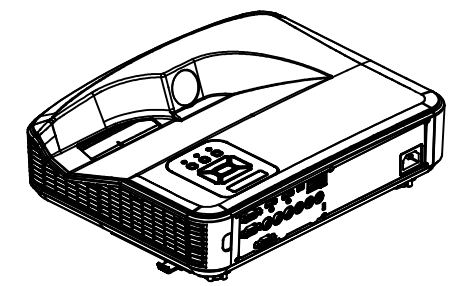
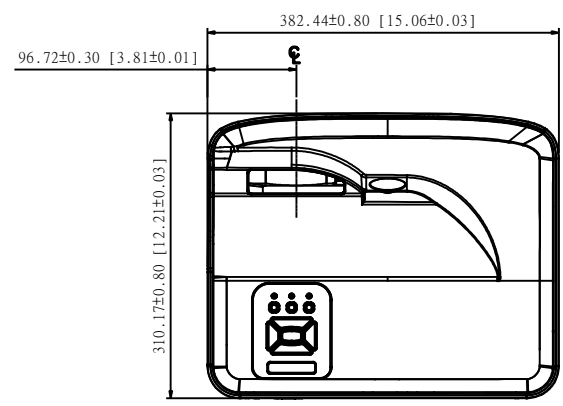
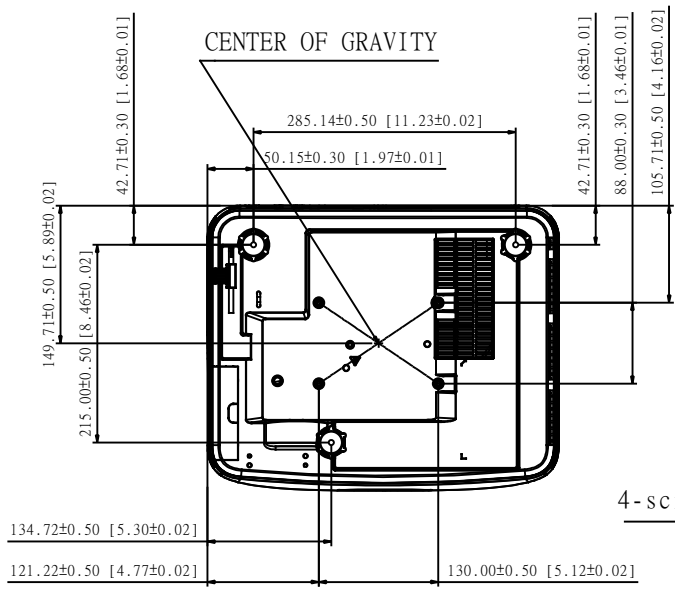

4-screws M4 with 10mm depth

GENERAL NOTES:
 MASS: 5.6 kg (12.35 lbs)
 OPERATING TEMPERATURE RANGE:
 5°C - 40°C (41°F - 104°F) @ 0-2500 FT
 5°C - 35°C (41°F - 95°F) @ 2500-5000 FT
 5°C - 30°C (41°F - 86°F) @ 5000-10000 FT
 POWER REQUIREMENTS:
 INPUT, 100VAC-240VAC , 4.0A , 50-60 HZ

UNITS: INCHES	MILLIMETERS	DATE: 2018/10/18	REV: 02	CHRISTIE CHRISTIE DIGITAL SYSTEMS USA, INC. CHRISTIE DIGITAL SYSTEMS CANADA, INC.
UNLESS OTHERWISE SPECIFIED		DATE: 2018/10/18	REV: 01	
INTERFERE DIMENSIONS AND TOLERANCES FOR ASSEMBLY		DATE: 2018/10/18	REV: 01	
TOLERANCES APPLY AS SHOWN BELOW		DATE: 2018/10/18	REV: 01	
PROPERTY:	NOT TO BE DISCLOSED OR REPRODUCED IN ANY MANNER WITHOUT WRITTEN PERMISSION FROM CHRISTIE	DATE: 2018/10/18	REV: 01	
THIRD ANGLE PROJECTION		DATE: 2018/10/18	REV: 01	
SCALE: 1:1		DATE: 2018/10/18	REV: 01	
DWG Line Captiva II			02	
E			020-001480-01	02
1/2			180 (E/G)	SHEET 1 OF 4

8

7

6

5

4

3

2

1

H

G

F

E

D

C

B

A

H

G

F

E

D

C

B

A

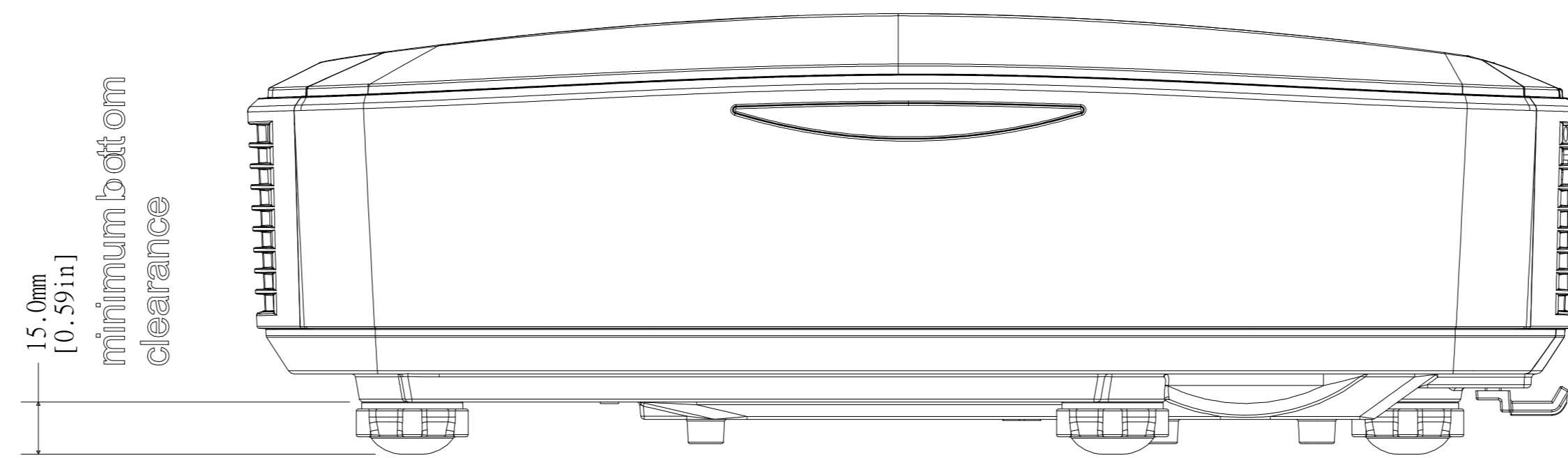
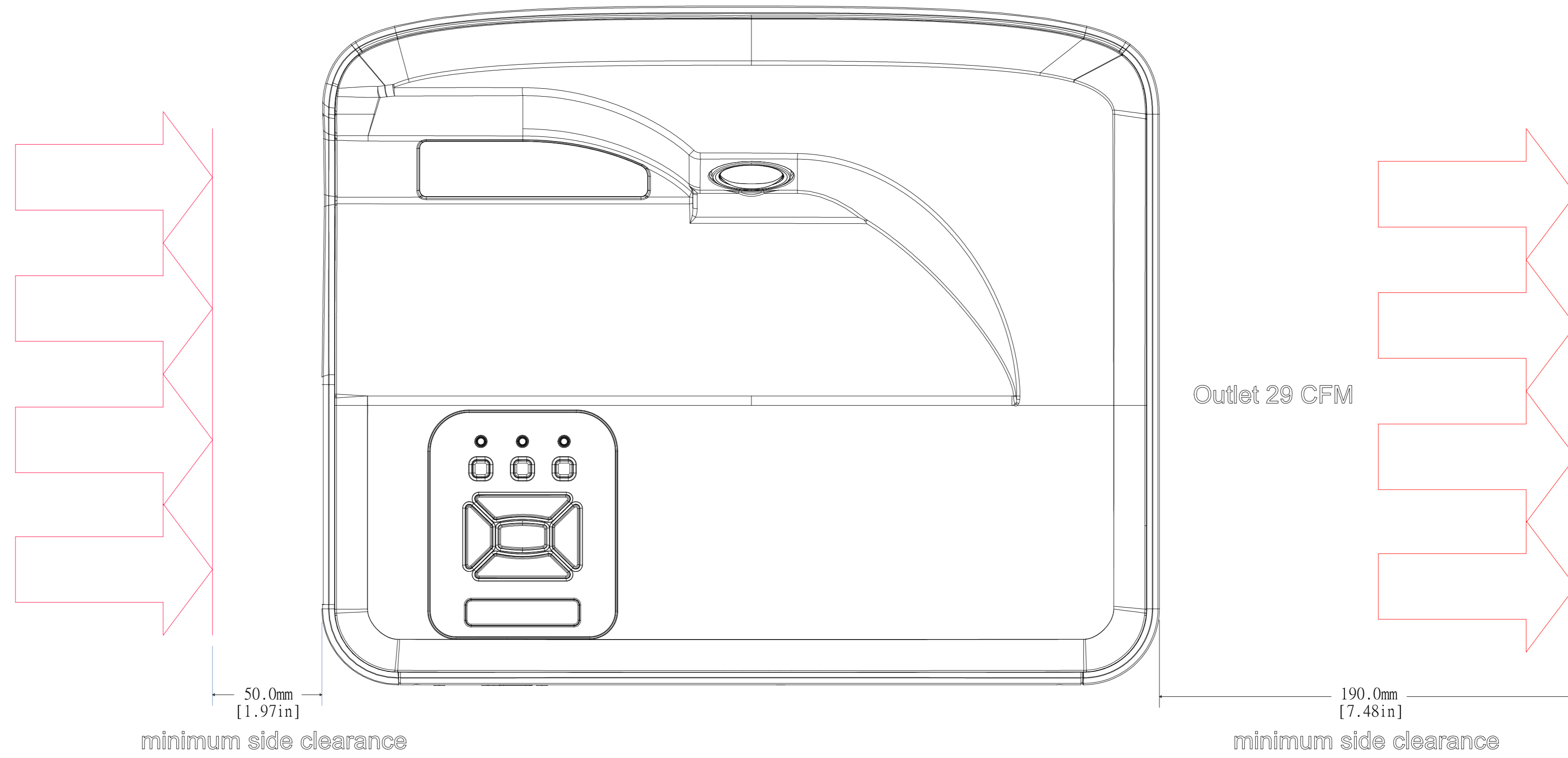

8

7

6

5

4

3

2

1

8

7

6

5

4

3

2

1

H
G
F
E
D
C
B
A

H
G
F
E
D
C
B
A

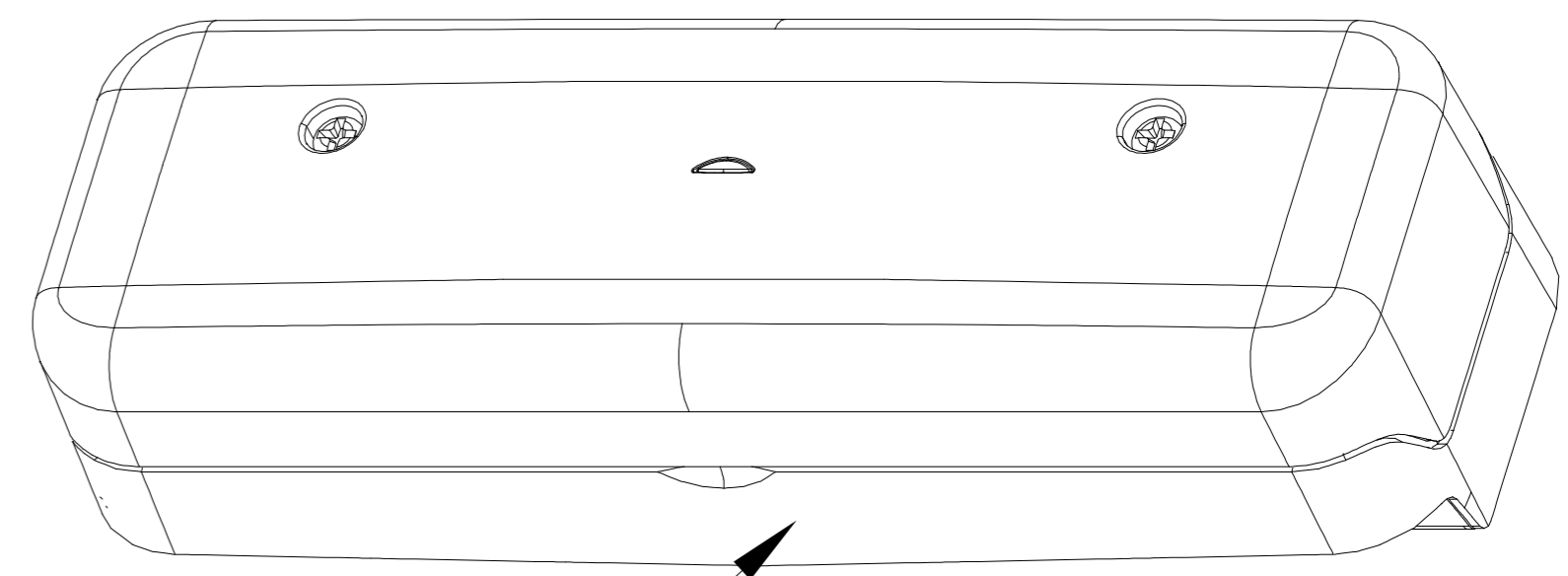
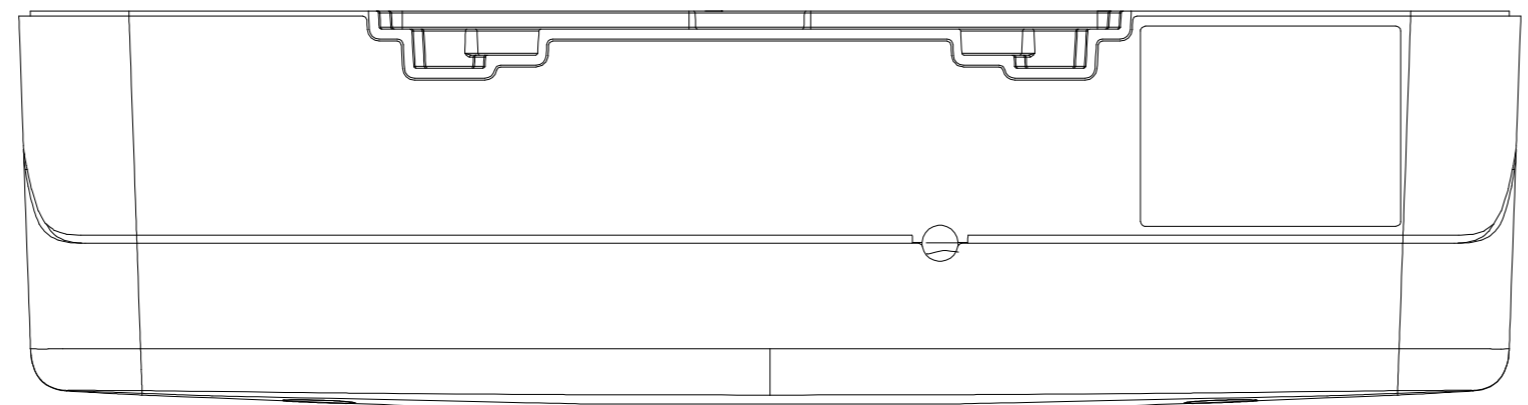

Captiva II touch
140-122106-XX

40.0±0.3 [1.57±0.01]

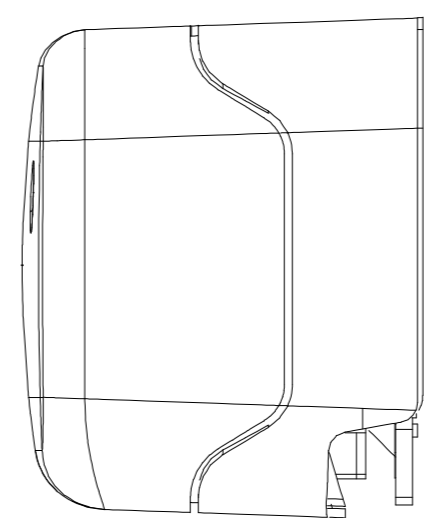
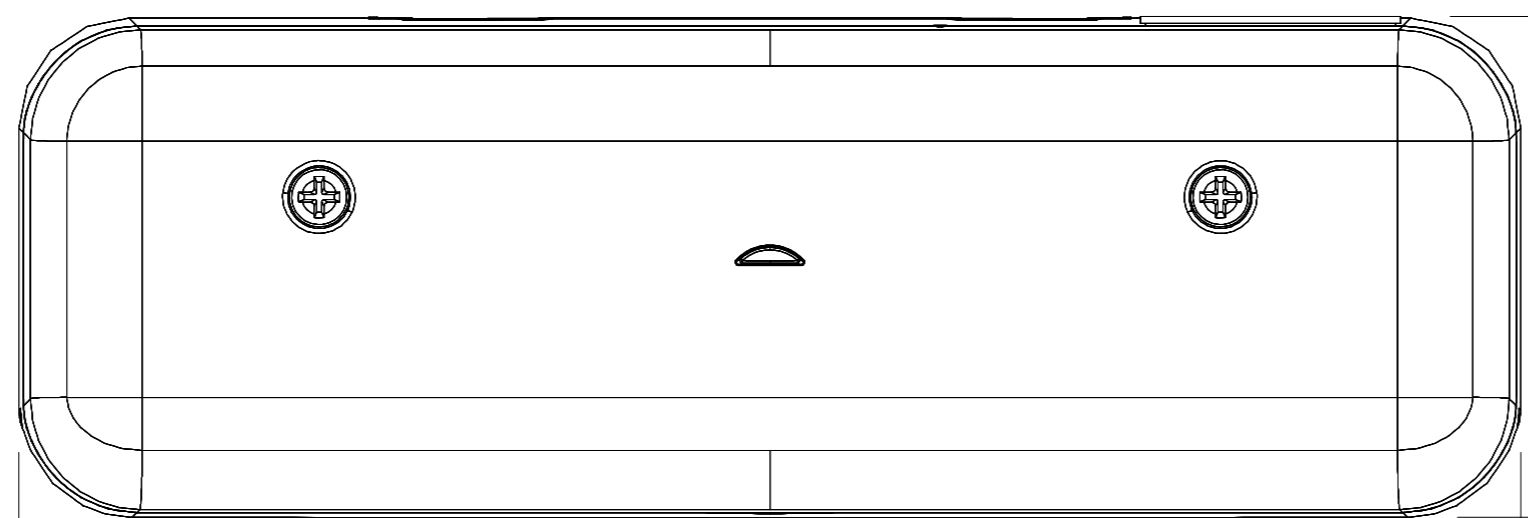
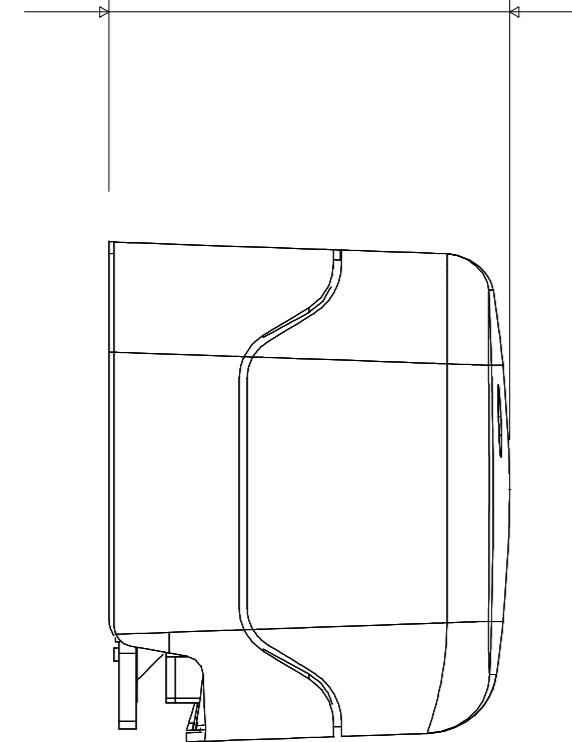

149.97±0.5 [5.9±0.02]

50.02±0.3 [1.97±0.01]

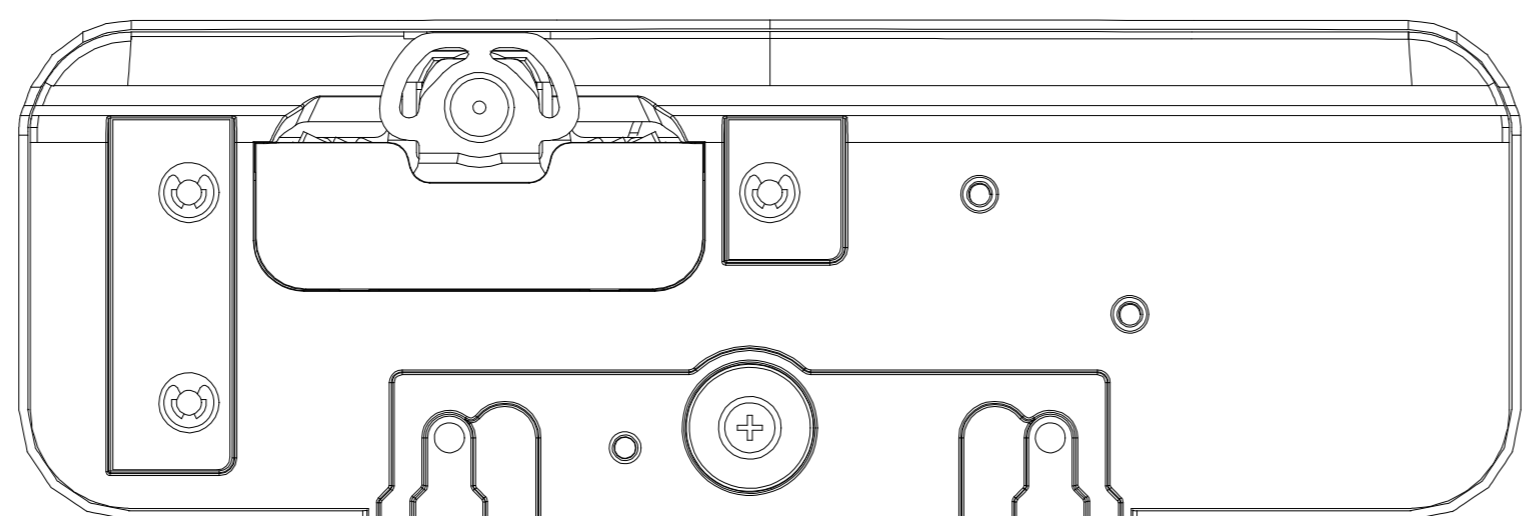
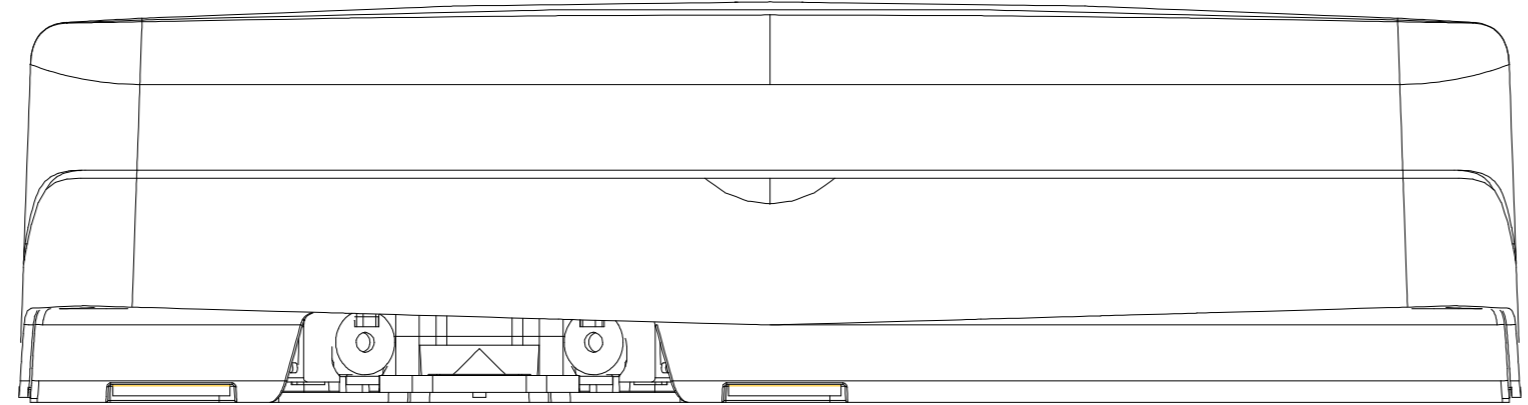

8

7

6

5

4

3

2

1

8

7

6

5

4

3

2

1

D=11.5±0.2[0.45±0.008]

D=8.9±0.2[0.35±0.008]

IR PEN 140-121105-XX

Detail A
Scale :2/1

Pen
Housing

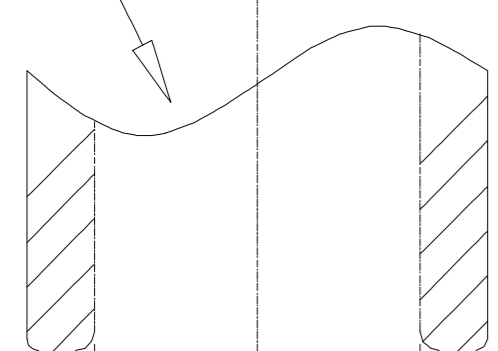

D=8.1^{+0.1}₋₀ [0.32^{+0.004}₋₀]

Pen
SW Cap

D=8.0±0.05[0.31±0.002]

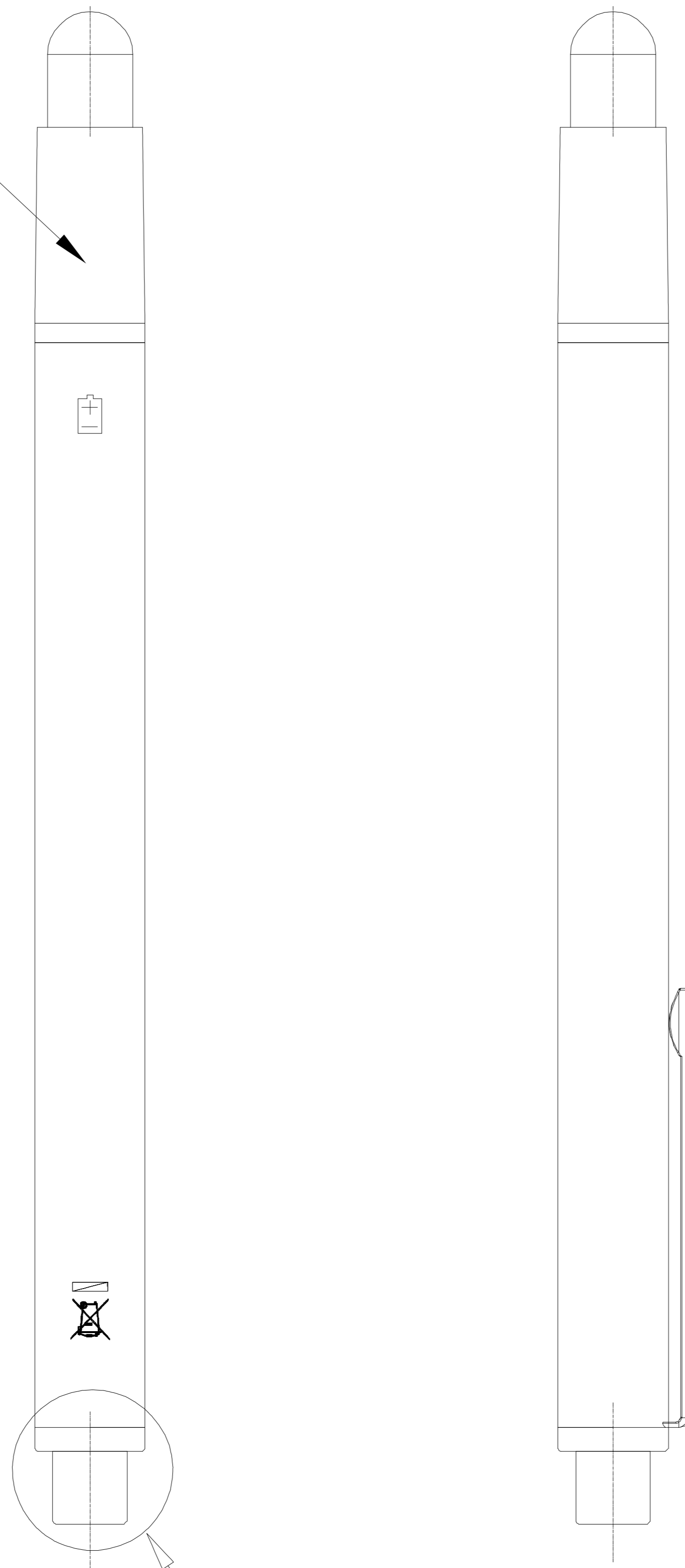
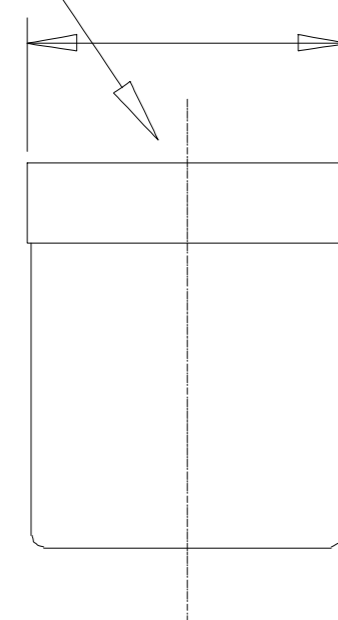

Detail A

12.1±0.2[0.48±0.008]

157.9±1.5[6.221±0.06]

D=7.8±0.2[0.31±0.008]

8

7

6

5

4

3

2

1

110±0.5 [4.33±0.02]

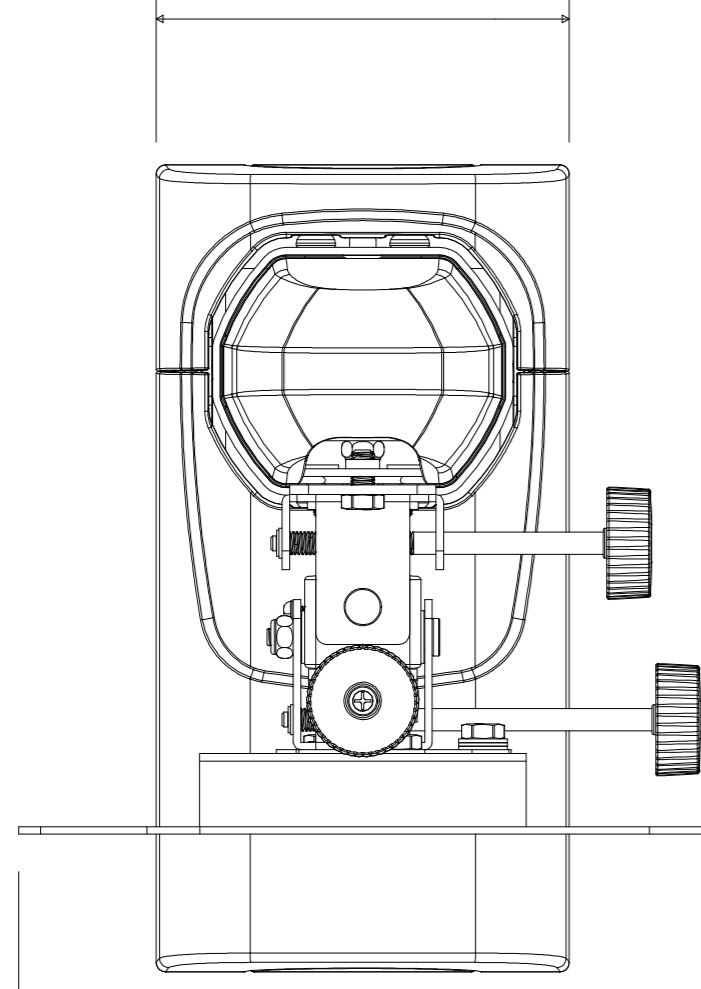

183±0.5 [7.2±0.02]

MAX 842.5±0.8 [33.17±0.03]

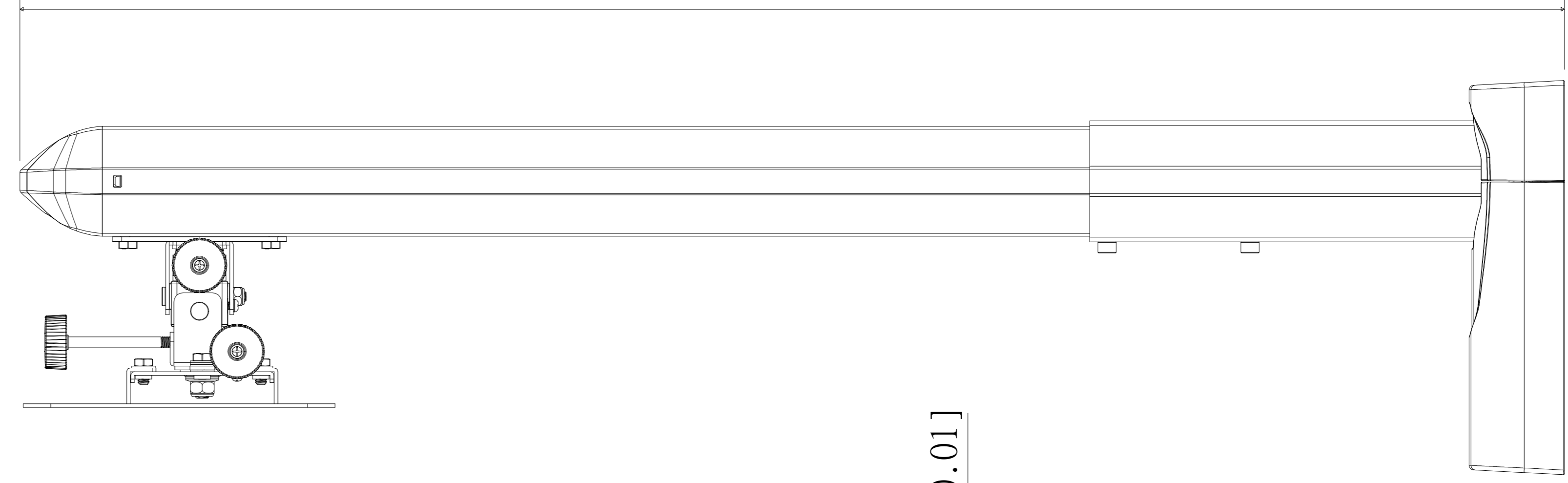

215±0.5 [8.46±0.02]

Wall Mount
140-120104-XX
or
140-120115-XX

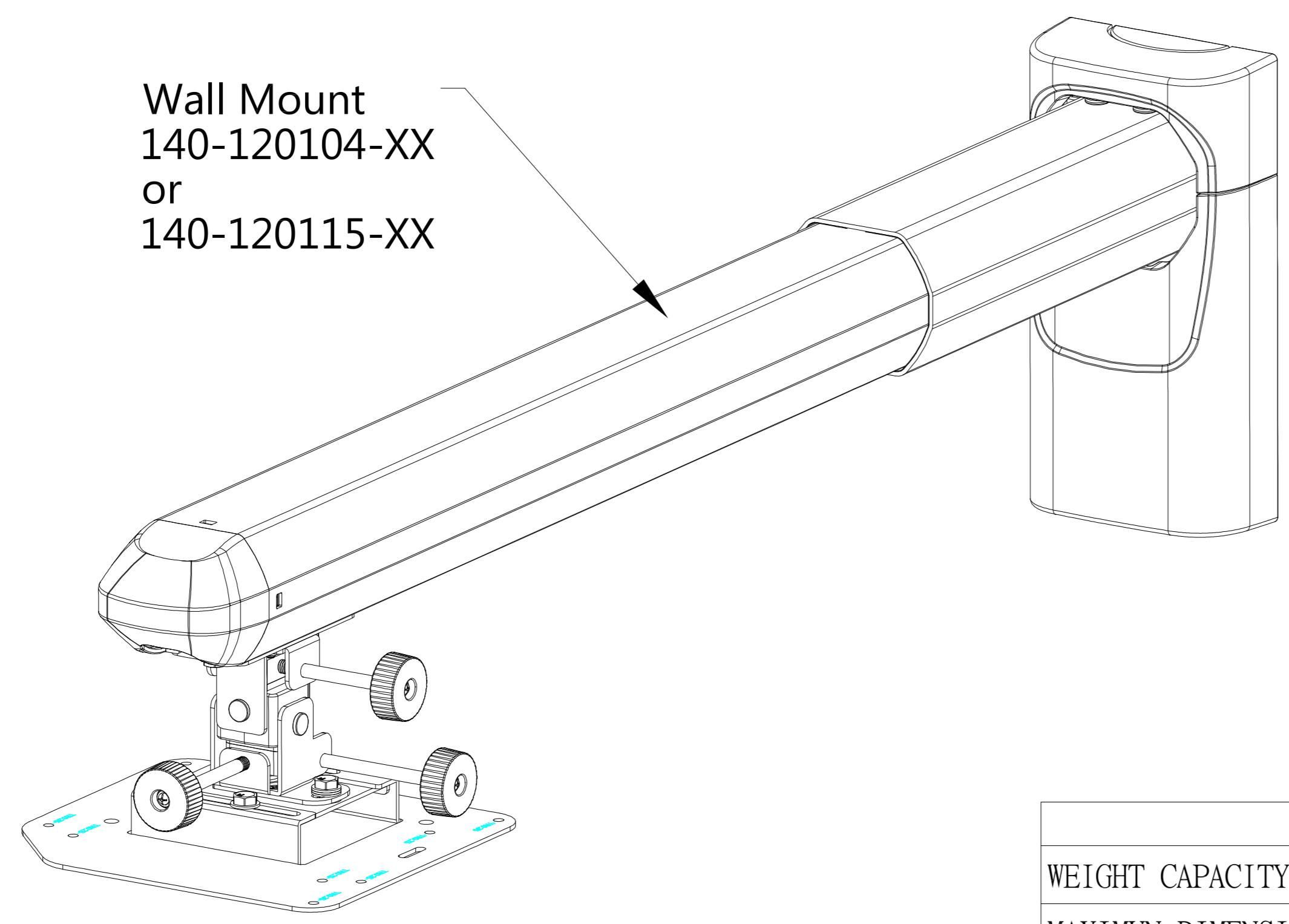

160±0.5 [6.30±0.02]
40±0.3 [1.57±0.01]
90±0.3 [3.54±0.01]

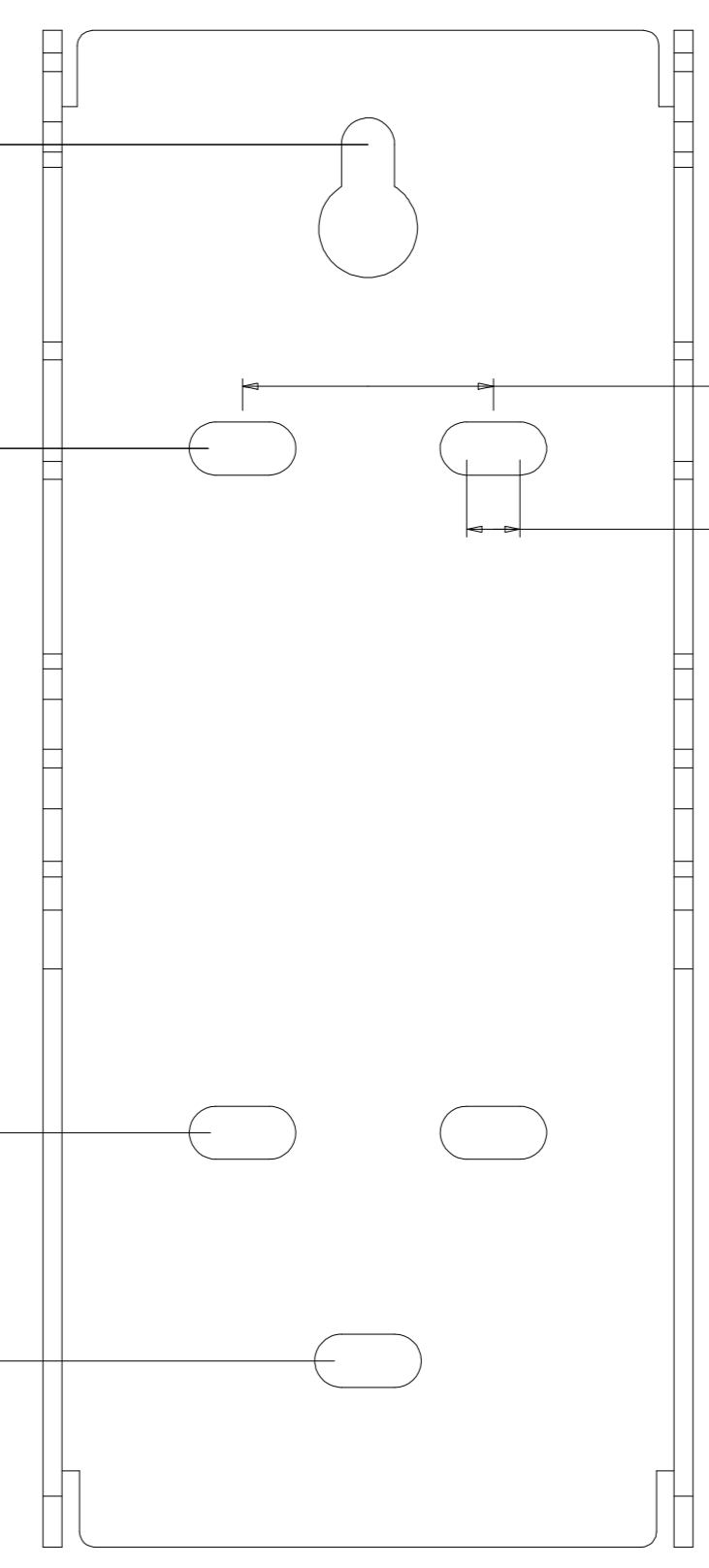

33±0.3 [1.3±0.01]

7.0±0.2 [0.28±0.008]

Wall mounting bracket
(not to scale)

SPECIFICATION

WEIGHT CAPACITY	15kg (33.11bs)
MAXIMUM DIMENSIONS	183 x 215 x 842.5 mm (7.2 x 8.46 x 33.17 inches)
PROJECTOR TILT ANGLE	±10°
SWIVEL	10°
MASS	3.33kg (7.34bs)

8

7

6

5

4

3

2

1

H
G
F
E
D
C
B
A

H
G
F
E
D
C
B
A

Wall Mount
140-120104-XX or 140-120115-XX

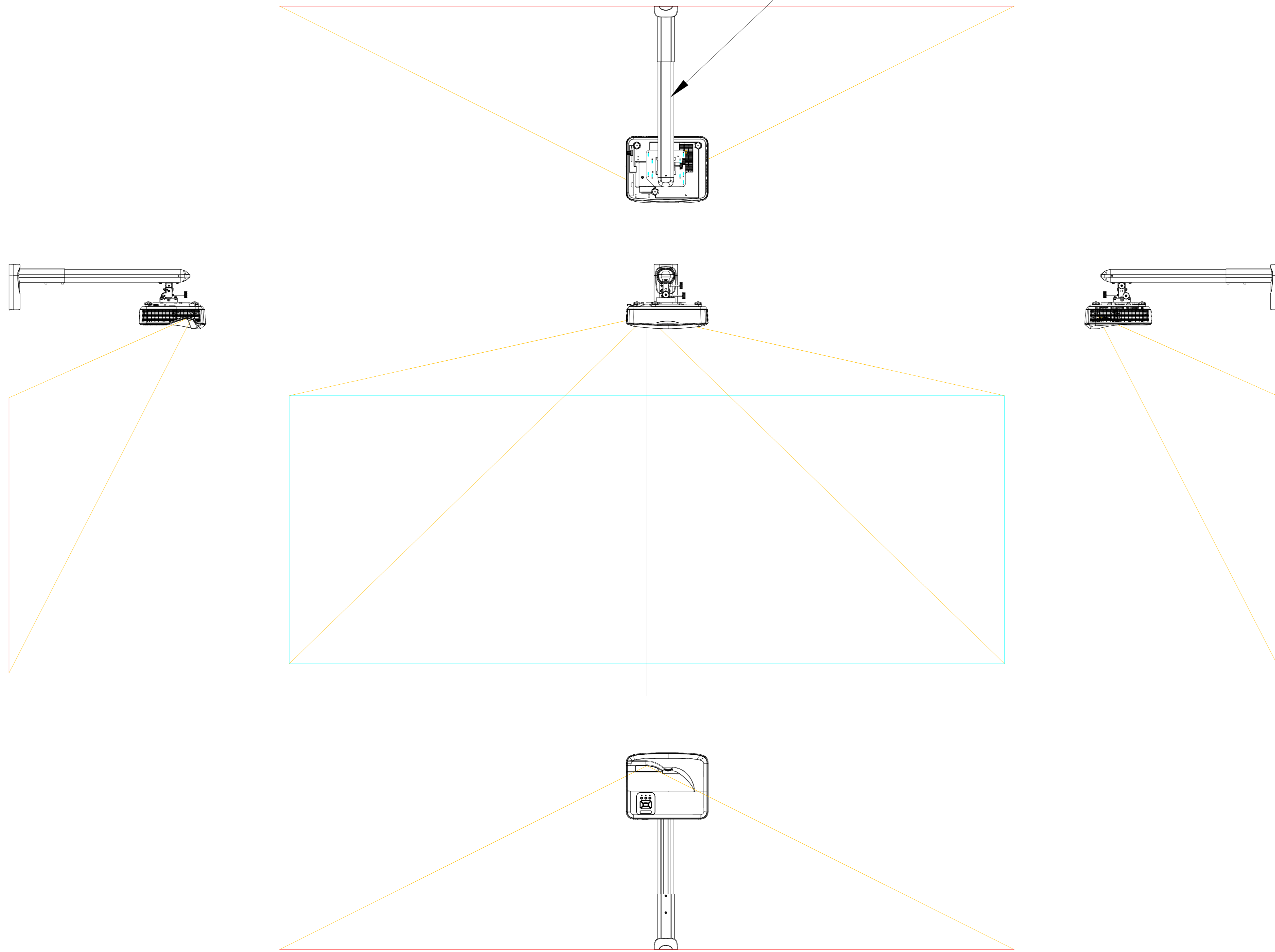

8

7

6

5

4

3

2

1