

The top half of the page features a complex, abstract background of overlapping, semi-transparent blue polygons in various shades, creating a dynamic, crystalline effect. This pattern transitions into a clean white background at the bottom.

Installation and Setup Guide

020-001464-02

# HS Series

D16WU-HS/D16HD-HS

D20WU-HS/D20HD-HS

**CHRISTIE®**

## NOTICES

### COPYRIGHT AND TRADEMARKS

Copyright ©2018 Christie Digital Systems USA Inc. All rights reserved.

All brand names and product names are trademarks, registered trademarks or trade names of their respective holders.

### GENERAL

Every effort has been made to ensure accuracy, however in some cases changes in the products or availability could occur which may not be reflected in this document. Christie reserves the right to make changes to specifications at any time without notice. Performance specifications are typical, but may vary depending on conditions beyond Christie's control such as maintenance of the product in proper working conditions. Performance specifications are based on information available at the time of printing. Christie makes no warranty of any kind with regard to this material, including, but not limited to, implied warranties of fitness for a particular purpose. Christie will not be liable for errors contained herein or for incidental or consequential damages in connection with the performance or use of this material. Canadian manufacturing facility is ISO 9001 and 14001 certified.

### WARRANTY

Products are warranted under Christie's standard limited warranty, the complete details of which are available by contacting your Christie dealer or Christie. In addition to the other limitations that may be specified in Christie's standard limited warranty and, to the extent relevant or applicable to your product, the warranty does not cover:

- a. Problems or damage occurring during shipment, in either direction.
- b. Problems or damage caused by combination of a product with non-Christie equipment, such as distribution systems, cameras, DVD players, etc., or use of a product with any non-Christie interface device.
- c. Problems or damage caused by misuse, improper power source, accident, fire, flood, lightning, earthquake, or other natural disaster.
- d. Problems or damage caused by improper installation/alignment, or by equipment modification, if by other than Christie service personnel or a Christie authorized repair service provider.
- e. Problems or damage caused by use of a product on a motion platform or other movable device where such product has not been designed, modified or approved by Christie for such use.
- f. Except where the product is designed for outdoor use, problems or damage caused by use of the product outdoors unless such product is protected from precipitation or other adverse weather or environmental conditions and the ambient temperature is within the recommended ambient temperature set forth in the specifications for such product.
- g. Defects caused by normal wear and tear or otherwise due to normal aging of a product.

The warranty does not apply to any product where the serial number has been removed or obliterated. The warranty also does not apply to any product sold by a reseller to an end user outside of the country where the reseller is located unless (i) Christie has an office in the country where the end user is located or (ii) the required international warranty fee has been paid.

The warranty does not obligate Christie to provide any on site warranty service at the product site location.

### PREVENTATIVE MAINTENANCE

Preventative maintenance is an important part of the continued and proper operation of your product. Failure to perform maintenance as required, and in accordance with the maintenance schedule specified by Christie, will void the warranty.

### REGULATORY

The product has been tested and found to comply with the limits for a Class A digital device, pursuant to Part 15 of the FCC Rules. These limits are designed to provide reasonable protection against harmful interference when the product is operated in a commercial environment. The product generates, uses, and can radiate radio frequency energy and, if not installed and used in accordance with the instruction manual, may cause harmful interference to radio communications. Operation of the product in a residential area is likely to cause harmful interference in which case the user will be required to correct the interference at the user's own expense.

### CAN ICES-3 (A)/NMB-3 (A)

이 기기는 업무용 (A 급) 으로 전자파적합등록을 한 기기이오니 판매자 또는 사용자는 이점을 주의하시기 바라며, 가정 외의 지역에서 사용하는 것을 목적으로 합니다.

### ENVIRONMENTAL

The product is designed and manufactured with high-quality materials and components that can be recycled and reused. This symbol  means that electrical and electronic equipment, at their end-of-life, should be disposed of separately from regular waste. Please dispose of the product appropriately and according to local regulations. In the European Union, there are separate collection systems for used electrical and electronic products. Please help us to conserve the environment we live in!

# Content

<b>Introduction</b> .....	<b>5</b>
Safety and warning guidelines .....	5
AC/power precautions .....	6
Installation safety and warning guidelines .....	6
Laser safety precautions .....	6
Light intensity hazard distance .....	7
Product labels .....	9
Projector overview .....	11
Contact your dealer .....	11
Key features .....	11
How the projector works .....	12
List of components .....	12
Product documentation .....	13
Related documentation .....	13
<b>Installation and setup</b> .....	<b>14</b>
Site requirements .....	14
Physical operating environment .....	14
Power connection .....	14
Physical specifications .....	14
Projector components .....	15
Front view .....	15
Rear view .....	15
Left view .....	16
Right view .....	16
Input/output (I/O) panel .....	17
IR remote keypad .....	18
Positioning the display .....	20
Installing the ceiling mount .....	21
Leveling the projector .....	21
Installing the projector lens .....	22
Calibrating the lens motor .....	22
Removing the projector lens .....	23
Removing and installing the fuse .....	24

Cleaning or installing the filter . . . . .	25
Connecting to AC power . . . . .	26
Turning on the projector . . . . .	27
Turning off the projector . . . . .	27
LED status indicator . . . . .	28
Status LED . . . . .	28
Shutter LED . . . . .	28
Calculating the lens offset . . . . .	29
Adjusting boresight . . . . .	31
<b>Connecting to devices . . . . .</b>	<b>33</b>
Connecting to a computer . . . . .	33
Connecting to video equipment . . . . .	34
<b>Signal connectivity specifications . . . . .</b>	<b>35</b>
Inputs . . . . .	35
Picture-in-picture/picture-by-picture (PIP/PBP) compatibility . . . . .	39
<b>Regulatory . . . . .</b>	<b>40</b>
Safety . . . . .	40
Laser safety . . . . .	40
Electro-magnetic compatibility . . . . .	40
Emissions . . . . .	40
Immunity . . . . .	41
Environmental . . . . .	41

# Introduction

This manual is intended for Christie qualified installers and trained operators of HS Series D16-20 projection systems.

For complete HS Series D16-20 product documentation and technical support, go to [www.christiedigital.com](http://www.christiedigital.com).

## Safety and warning guidelines

Read all safety and warning guidelines before installing or operating the projector. This projector must be operated in an environment that meets the operating range specification. Use only the attachments and/or accessories recommended by Christie. Use of others may result in the risk of fire, shock, or personal injury.



**Warning!** If not avoided, the following could result in death or serious injury.

- Do not expose the product to moisture.
- Do not operate the product without all of its covers in place.
- This product must be installed within a restricted access location not accessible by the general public.
- Only personnel who are trained on the precautions for the restricted access location can be granted entry to the area.
- FIRE HAZARD! Keep hands, clothes, and all combustible material away from the concentrated light beam of the projector.
- TRIP OR FIRE HAZARD! Position all cables where they cannot contact hot surfaces, be pulled, be tripped over, or damaged by persons walking on or objects rolling over the cables.
- SHOCK HAZARD! Disconnect the product from AC before installing, moving, servicing, cleaning, removing components, or opening any enclosure.
- OPTICAL RADIATION HAZARD! Disconnect the power plug from the AC outlet if the product is not being used for an extended period of time.
- Do not allow anything to rest on the power cord.
- Always provide proper ventilation for the product to prevent overheating.



**Caution!** If not avoided, the following could result in minor or moderate injury.

- Only Christie qualified technicians are permitted to open product enclosures.
- All procedures must be performed by Christie qualified technicians.



**Notice.** If not avoided, the following may result in equipment or property damage.

- Always use a lens plug when installing or moving the product. This prevents contaminants from entering the product.
- Only use cleaning solutions recommended by Christie. All other cleaning solutions may cause product damage and will void the warranty.

## AC/power precautions

Read all AC/power precautions before installing or operating the projector.



**Warning!** If not avoided, the following could result in death or serious injury.

- FIRE HAZARD! Do not use a power cord, harness, or cable that appears damaged.
- FIRE OR SHOCK HAZARD! Do not overload power outlets and extension cords.
- SHOCK HAZARD! Only use the AC power cord provided with the product or recommended by Christie.
- FIRE AND SHOCK HAZARD! Do not attempt operation unless the power cord, power socket, and power plug meet the appropriate local rating standards.
- SHOCK HAZARD! Do not attempt operation if the AC supply is not within the specified voltage and current, as specified on the license label.
- SHOCK HAZARD! The AC power cord must be inserted into an outlet with grounding.
- SHOCK HAZARD! Disconnect the product from AC before installing, moving, servicing, cleaning, removing components, or opening any enclosure.
- Install the product near an easily accessible AC receptacle.

## Installation safety and warning guidelines

Read all installation safety and warning guidelines before installing the projector.



**Warning!** If not avoided, the following could result in death or serious injury.

- High leakage current present when connected to IT power systems.



**Caution!** If not avoided, the following could result in minor or moderate injury.

- ELECTRICAL and BURN HAZARD! Use caution when accessing internal components.
- Only Christie qualified technicians are authorized to use the tools provided in the toolbox.

## Laser safety precautions

This projector has been classified as Class 1 Laser Product-Risk Group 3 according to the IEC 62471:2006, IEC 60825-1:2014 and IEC 62471-5:2015 standard. Read all safety and warning guidelines before installing or operating the projector.



**Warning!** If not avoided, the following could result in death or serious injury.

- PERMANENT/TEMPORARY BLINDNESS HAZARD! No direct exposure to the beam must be permitted.
- LASER RADIATION HAZARD! This projector has a built-in Class 4 laser module. Never attempt to disassemble or modify the laser module.
- Possibly hazardous optical radiation emitted from this product.
- Only Christie qualified technicians who are knowledgeable about the hazards associated with laser use, high-voltage, and high temperatures generated by the product are authorized to assemble, install, and service the Christie Laser Projection System.
- Do not look directly into the lens when the light source is on. The extremely high brightness can cause permanent eye damage.
- Do not operate the product without all of its covers in place.

## Light intensity hazard distance

This projector has been classified as Risk Group 3 according to the IEC 62471:2006 and IEC 62471-5:2015 standard due to possible hazardous optical and thermal radiation being emitted.



**Warning!** If not avoided, the following could result in death or serious injury.

- PERMANENT/TEMPORARY BLINDNESS HAZARD! No direct exposure to the beam must be permitted.
- PERMANENT/TEMPORARY BLINDNESS HAZARD! Operators must control access to the beam within the hazard distance or install the product preventing potential exposure of the spectators' eyes from being in the hazard distance. Hazard zone shall be no lower than 3.0 meters above the floor. In addition, horizontal clearance to the hazard zone shall be a minimum 2.5 meters.
- EXTREME BRIGHTNESS! Do not place reflective objects in the product light path.

The following diagram shows the zones for optical and skin hazard distances:

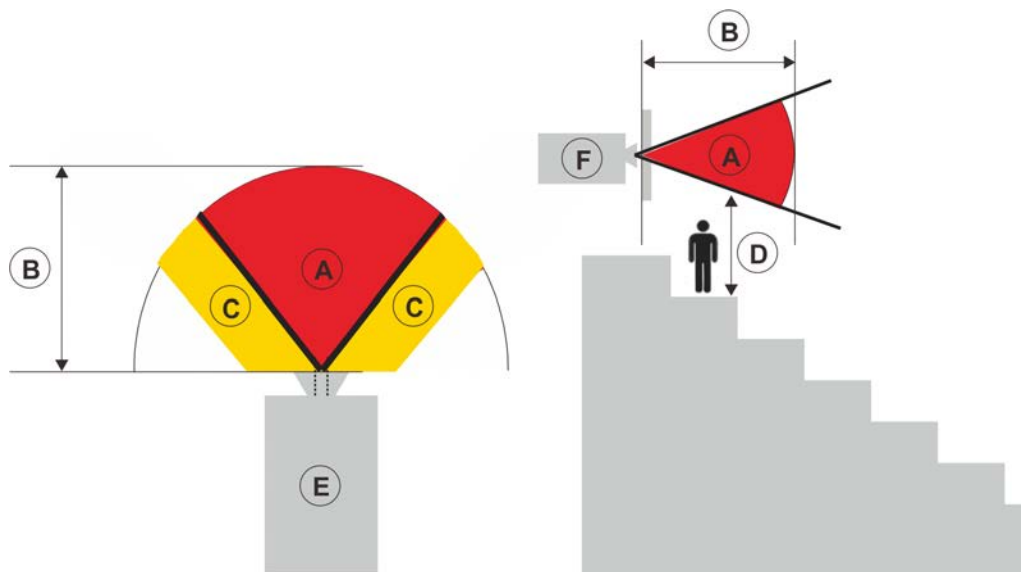

- A—Hazard zone. The region of space where the projection light from the laser illuminated projector is above emission limits for Risk Group 2. The light intensity may cause eye damage after a momentary or brief exposure (before a person can avert his or her eyes away from the light source). The light may cause skin burns to occur.
- B—Hazard distance. Operators must control access to the beam within the hazard distance or install the product preventing potential exposure of the spectators' eyes from being in the hazard distance.
- C—No access zone. Horizontal clearance of the no access zone shall be a minimum of 2.5 meters.
- D—Vertical distance to hazard zone. The hazard zone shall be no lower than 3.0 meters above the floor.
- E—Represents the top view of the projector.
- F—Represents the side view of the projector.

For US market only, hazard distances based upon FDA guidance document 1400056, *Classification and Requirements for Laser Illuminated Projectors (LIPs)*, dated February 18, 2015:

Projection lens	Part number	Hazard distance (m)
0.84-1.02:1 zoom lens	140-114107-XX	1.0
1.02-1.36:1 zoom lens	140-115108-XX	1.0
1.2-1.5:1 zoom lens	140-109101-XX	1.0
1.5-2.0:1 zoom lens	140-110103-XX	1.6
2.0-4.0:1 zoom lens	140-111104-XX	1.6
4.0-7.2:1 zoom lens	140-116109-XX	2.8

For all other markets, hazard distances based upon IEC 62471-5:2015, *Photobiological safety of lamps and lamp systems – Part 5: Image projectors*:

Projection lens	Part number	Hazard distance (m)
0.84-1.02:1 zoom lens	140-114107-XX	1.0
1.02-1.36:1 zoom lens	140-115108-XX	1.0
1.2-1.5:1 zoom lens	140-109101-XX	1.0
1.5-2.0:1 zoom lens	140-110103-XX	1.0
2.0-4.0:1 zoom lens	140-111104-XX	1.0
4.0-7.2:1 zoom lens	140-116109-XX	1.6

## For installations in the United States

The following must be in place for laser-illuminated projector installations in the United States:

- Any human access to the hazard zone, if applicable, must be restricted by barriers to enforce the no access zone.
- Permanent show installations containing Risk Group 3 laser-illuminated projectors must meet the following conditions:
  - Installed by Christie or by Christie-authorized and trained installers. Refer to the Laser Illuminated Projector-Class 1 Risk Group 3 Installation training (Course code: CF-LIPI-01) on the <http://www.christieuniversity.com> site.
  - Performed according to instructions provided by Christie.
  - Ensure the projection system is securely mounted or immobilized to prevent unintended movement or misalignment of the projections.
- Temporary show installations containing Risk Group 3 laser-illuminated projectors may be installed by Christie or sold or leased only to valid laser light show variance holders (laser light show manufacturers) for image projection applications. Such manufacturers may currently hold a valid variance for production of Class IIIb and IV laser light shows and/or for incorporation of the Risk Group 3 laser-illuminated projectors into their shows. This requirement applies also to dealers and distributors of these laser-illuminated projectors.













- The Christie Laser Projection System Installation Checklist must be fully completed after the installation and sent to [lasercompliance@christiedigital.com](mailto:lasercompliance@christiedigital.com). A copy can remain on-site. This checklist can be found as a separate document in the accessory box with the manual.
- If installing in the US states of Arizona, Florida, Georgia, Illinois and Massachusetts, go to [www.christiedigital.com](http://www.christiedigital.com) for additional regulatory requirements.

## Product labels

Learn about the labels that may be used on the product. Labels on your product may be yellow or black and white.

### General hazards

Hazard warnings also apply to accessories once they are installed in a Christie product that is connected to power.

Fire and Shock Hazard	
 	<p>To prevent fire or shock hazards, do not expose this product to rain or moisture.</p> <p>Do not alter the power plug, overload the power outlet, or use it with extension Cords.</p> <p>Do not remove the product enclosure.</p> <p>Only Christie qualified technicians are authorized to service the product.</p>
Electrical Hazard	
	<p>Risk of electric shock.</p> <p>Do not remove the product enclosure.</p> <p>Only Christie qualified technicians are authorized to service the product.</p>
	<p>General hazard.</p>
	<p>Electric shock hazard. To avoid personal injury, disconnect all power sources before performing maintenance or service.</p>
	<p>Electrocution hazard. To avoid personal injury, always disconnect all power sources before performing maintenance or service procedures.</p>
	<p>Fire hazard. To avoid personal injury and property damage, follow the instructions provided in this document.</p>
	<p>Hot surface hazard. To avoid personal injury, allow the product to cool for the recommended cool down time before performing maintenance or service.</p>
	<p>Burn hazard. To avoid personal injury, allow the product to cool for the recommended cool down time before performing maintenance or service.</p>
	<p>Bright light hazard. To avoid personal injury, never look directly at the light source.</p>



Moving parts hazard. To avoid personal injury, keep hands clear and loose clothing tied back.



Fan hazard. To avoid personal injury, keep hands clear and loose clothing tied back. Always disconnect all power sources before performing maintenance or service procedures.



Voltage hazard. To avoid personal injury, always disconnect all power sources before performing maintenance or service procedures.



Not for household use.

### Mandatory action



Consult the service manual.



Disconnect all power sources before performing maintenance or service procedures.

### Electrical labels



Indicates the presence of an earth ground.

### Laser labels

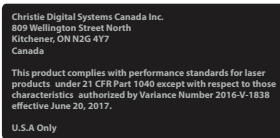

FDA laser variance (US projectors only)



Indicates a light hazard. Do not look directly into the lens. The extreme high brightness can cause permanent eye damage. Class 1 Laser Product-Risk Group 3 according to Class 1 IEC 60825-1:2014 and IEC 62471:2006.

### Additional hazard labels



Do not look directly into the lens. The extremely high brightness can cause permanent eye damage.

## Projector overview

The HS Series D16-20 is a high brightness, professional projector system designed with laser phosphor technology and Digital Light Processing (DLP™) technology from Texas Instruments. Both HD and WUXGA resolutions are available for demands and environments. With its superior image quality and high brightness level, the product can be used for various large venue application ranging from fixed installation, rental stage and LBE (Location Based Entertainment), but not intend to use for domestic purpose.

## Contact your dealer

Record the information about your projector and keep this information with your records to assist with the servicing of your projector. If you encounter a problem with your Christie projector, contact your dealer.

Purchase record	
Dealer:	
Dealer or Christie Sales/Service contact phone number:	
Projector serial number: The serial number can be found on the license label located on the display panel	
Purchase date:	
Installation date:	

Ethernet settings	
Default gateway	
Projector IP address	
Subnet mask	

## Key features

Understand the important features of the projector.

- HD 0.95" 1920 × 1080 resolution or WUXGA 0.96" 1920 × 1200 resolution
- High picture quality with superb brightness performance
- Lens suite options for installation flexibility
- Powered lens adjustment with lens memory function
- Projection lens compatibility:
  - Horizontal offset ranges with half image size: up to +/-50%
  - Vertical offset ranges with half image size: up to +/-120% (WUXGA) and +/-140% (HD)  
Measurements comply with industry standards where offset is calculated as a ratio of the number of pixels shifted up or down to half image size.

- 360 degrees projection
- 3D blending and auto warping
- Supports fog filter as an optional accessory
- Full HD 3D technology with frame sequential up to 120 Hz
- Christie Twist™ allows for easy and quick blending and warping
- A wide range of connectivity including HDMI, HDBaseT, and 3D inputs
- Integrated HDBaseT solution supports HD video streaming through RJ45
- Wireless desktop display using wireless dongle (optional)
- SNMP traps and email notifications
- 10-bit image processor electronics with modular design
- All video formats can be resized to full screen either horizontally or vertically while maintaining aspect ratio.
- The projector can be operated using any of the following:
  - The built-in keypad, the infrared (IR) remote keypad, a wired remote keypad, or a PC/ device using serial communications (Ethernet or RS232)
  - A web page using Ethernet, or from a PC or device using a wireless USB dongle (optional)

## How the projector works

The HS series D16-20 projector accepts a variety of input signals for a wide range of commercial projection applications.

Designed with solid-state illumination light sources and phosphor technology, the red, green and blue color elements are segmented through a phosphor wheel and then modulated by one Digital Micromirror Device (DMD) panels responding to incoming data streams of digitized red, green, and blue color information. As these digital streams flow from the source, light from the responding on pixels of each panel is reflected, converged, and then projected to the screen through projection lenses, where all pixel reflections are superimposed in sharp full-color images.

## List of components

This projector comes with all the items listed below. Check to make sure your package is complete. If anything is missing, contact your dealer.

- AC power cord
- IR remote keypad and batteries
- Product Safety Guide

## Product documentation

For installation, setup, and user information, see the product documentation available on the Christie Digital Systems USA Inc. website. Read all instructions before using or servicing this product.

1. Access the documentation from the Christie website:
  - Go to this URL: <http://bit.ly/2JtghsE> or <https://www.christiedigital.com/en-us/business/products/projectors/1-chip-dlp/hs-series>
  - Scan the QR code using a QR code reader app on a smartphone or tablet.

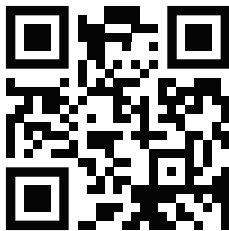

2. On the product page, select the model and switch to the **Downloads** tab.

## Related documentation

Additional information on the projector is available in the following documents.

- *HS Series D16-20 Installation and Setup Guide (P/N: 020-001464-XX)*
- *HS Series D16-20 Product Safety Guide (P/N: 020-001465-XX)*
- *HS Series D16-20 User Manual (P/N: 020-001466-XX)*
- *HS Series D16-20 Specification Guide (P/N: 020-001467-XX)*
- *HS Series D16-20 Service Manual (P/N: 020-001468-XX)*
- *Twist User Guide (P/N: 020-101380-XX)*

# Installation and setup

Learn how to install, connect, and optimize the projector display.

## Site requirements

To safely install and operate the projector, the installation location must have restricted access for authorized personnel only and meet these minimum requirements.

### Physical operating environment

Provides specifications for the operating environment.

- Ambient temperature (operating): 0°C to 40°C (32°F to 104°F) up to 2500 ft
- Humidity (non-condensing): 10% to 85% RH
- Operating altitude: 10,000 ft maximum at 0°C to 30°C ambient temperature

### Power connection

The projector uses an AC power system that allows the projector to operate at full brightness with a power supply of 120-240 VAC or 200-240 VAC, depending on the models and regions. Operating the device outside of the voltage range may cause unsatisfactory operation or damage to the projector. Christie recommends a 20 A rated wall breaker for the installation. To ensure safe operation, only use the AC power cord provided with the product or recommended by Christie. See [Connecting to AC power](#) on page 26 for further information on the power requirements.

## Physical specifications

Learn the dimensions and weight of the projector before installation.

- Projection size, excluding lens, feet (L x W x H): 26.6 x 23.5 x 8.0" (677 x 596 x 203 mm)
- Shipping size, without lens (L x W x H): 38 x 31.3 x 14.4" (965 x 795 x 365 mm)
- Weight, without lens: 41.6 kg (91.52 lbs)
- Shipping weight, without lens: 53.3 kg (117.7 lbs)

## Projector components

Identify the main components of the projector.

### Front view

Identify the main components on the front of the projector.

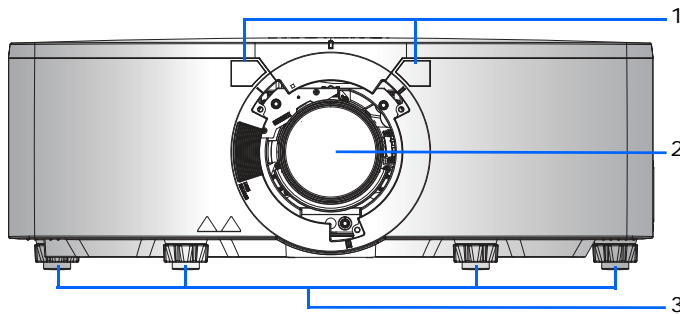

ID	Part name	Description
1	Front IR sensors	Receives signals from the IR remote keypad. Keep the signal path to the sensor unobstructed for uninterrupted communication with the projector.
2	Projection lens	Allows automated lens control and adjustment: vertical and horizontal offsets, zoom, and focus.
3	Adjustable feet	Raises or lowers the feet to level the projector.

### Rear view

Identify the main components on the rear of the projector.

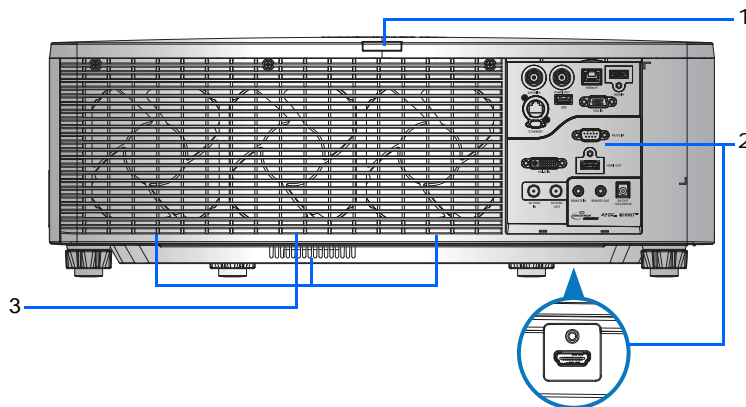

ID	Part name	Description
1	Rear IR sensor	Receives signals from the IR remote keypad. Keep the signal path unobstructed for uninterrupted communication with the projector.
2	Input/Output (I/O) panel	Connects the projector to external devices.

ID	Part name	Description
3	Cooling air vents (exhaust)	Provides cooling to the projector. Keep these vents unobstructed to prevent the projector from overheating.

## Left view

Identify the main components on the left side of the projector.

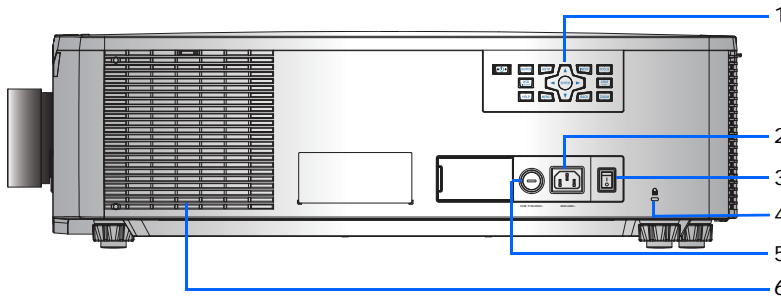

ID	Part name	Description
1	Built-in keypad	Controls the projector.
2	AC input	Connects to the supplied power adapter.
3	Power button	Powers the projector on or off.
4	Kensington lock	Secures the projector to counter tops, tables, and so on.
5	Fuse	FUSE T15 A/250 VAC
6	Cooling air vents (intake)	Provides cooling to the projector. Keep these vents unobstructed to prevent the projector from overheating.

## Right view

Identify the main component on the right side of the projector.

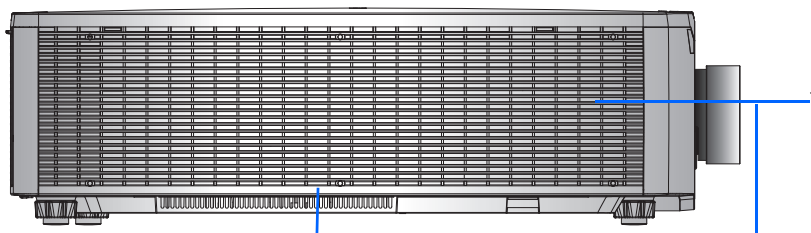

ID	Part name	Description
1	Cooling air vents (intake)	Provides cooling to the projector. Keep these vents unobstructed to prevent the projector from overheating.



# Input/output (I/O) panel

Identify the components of the I/O panel.

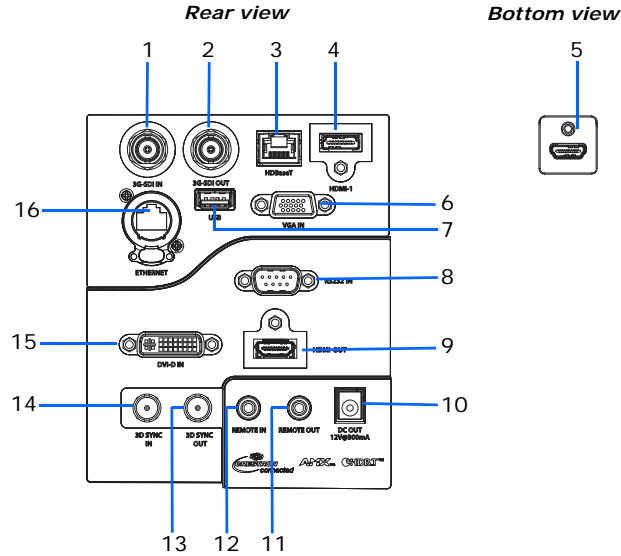

ID	Connector name	ID	Connector name
1	3G-SDI IN	9	HDMI OUT
2	3G-SDI OUT	10	DC OUT
3	HDBaseT	11	REMOTE OUT
4	HDMI-1	12	REMOTE IN
5	HDMI-2	13	3D SYNC OUT
6	VGA IN	14	3D SYNC IN
7	USB (5 V/500 mA)	15	DVI-D IN
8	RS232 IN	16	ETHERNET (10/100 Mbps)

## IR remote keypad

The IR remote keypad communicates with the projector by way of wireless communications. Use a cable length of 20 m or less. If the length of cable exceeds 20 m, the IR remote keypad may not work correctly.

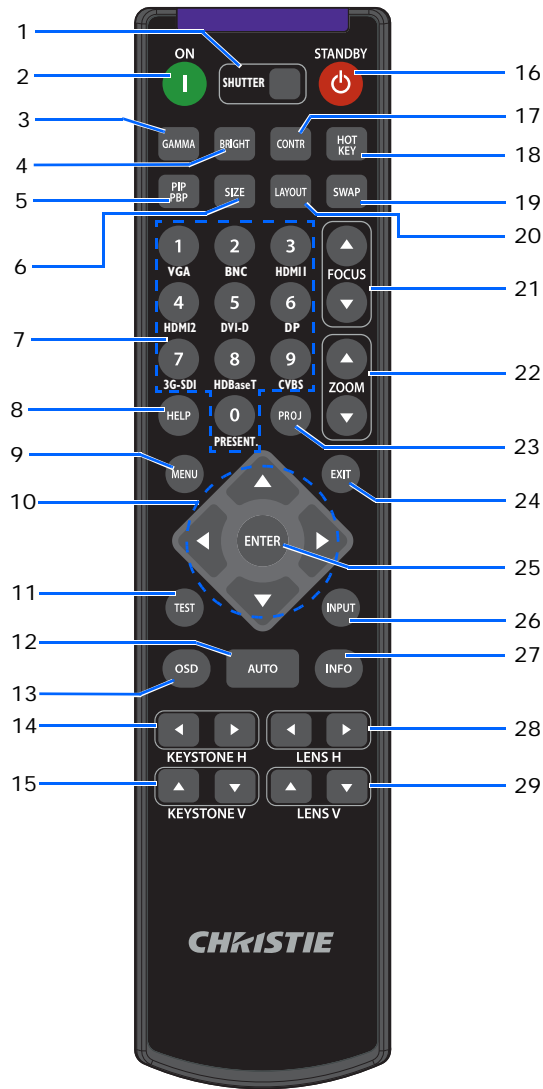

ID	Button	Description
1	SHUTTER	Displays or blanks the video image.
2	ON	Turns the projector on.
3	GAMMA	Adjusts the mid-range levels.
4	BRIGHT	Adjusts the amount of light in the image.

ID	Button	Description
5	PIP PBP	Turns picture-in-picture/picture-by-picture (PIP/PBP) on or off.
6	SIZE	Adjusts the PIP/PBP size.
7	Number Keys	Enter a number, such as a channel, value, and so on. The on-screen display (OSD) indicates if a function is not supported.
8	HELP	Displays the instructions for source connection.
9	MENU	Displays the menus.
10	Arrow Keys	Adjusts a setting up or down to navigate within a menu.
11	TEST	Displays a test pattern.
12	AUTO	Automatically optimizes an image.
13	OSD	Hides or shows OSD menus.
14	KEystone H	Adjusts the horizontal keystone.
15	KEystone V	Adjusts the vertical keystone.
16	STANDBY	Turns the projector off.
17	CONTR	Adjusts the difference between dark and light.
18	HOT KEY	Selects your preset key quickly.
19	SWAP	Swaps the main and PIP/PBP images.
20	LAYOUT	Adjusts the PIP/PBP layout.
21	FOCUS	Adjusts the focus to improve image clarity as required.
22	ZOOM	Adjusts the zoom to achieve a required image size.
23	PROJ	Changes the IR remote keypad ID. To assign an ID, press <b>PROJ</b> + <1 to 9>. To return to the universal IR remote ID, press <b>PROJ</b> + 0.
24	EXIT	Returns to the previous level or exits menus if at the top level.
25	ENTER	Selects a highlighted menu item, or changes or accepts a value.
26	INPUT	Selects an input for the main or PIP/PBP image.
27	INFO	Displays the source image information.
28	LENS H	Adjusts the position of the image horizontally.
29	LENS V	Adjusts the position of the image vertically.

## Positioning the display

When you select a position for the projector, consider the size and shape of your screen, the location of your power outlets, and the distance between the projector and the rest of your equipment. Follow these general guidelines:

- Position the projector on a flat surface at a right angle to the screen. The projector (with the standard lens) must be at least 5.2 ft (1.6 m) from the projection screen.
- Position the projector to the required distance from the screen. The distance from the lens of the projector to the screen, the zoom setting, and the video format determine the size of the projected image.
- Determine the lens throw ratio.

For more information detailing the throw ratio for each lens, refer to the *HS Series D16-20 Specification Guide (P/N: 020-001467-XX)*.

- 360 degree free orientation operation

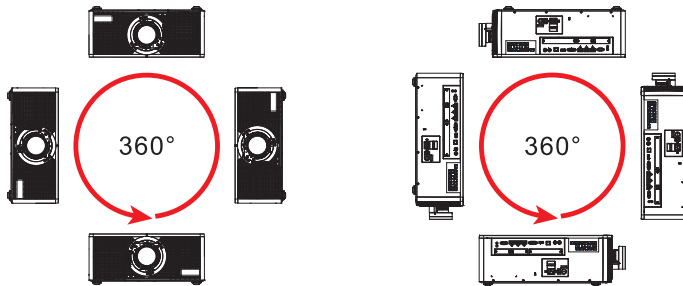

When installing the projector in portrait orientation, Christie recommends that the built in keypad and power inputs face upwards. This allows access to the built in keypad and power connections during operation.

## Installing the ceiling mount

Mount the projector with a Christie-approved mount or rigging frame (such as Christie One Mount Plus, P/N: 140-117100-XX, or Christie One Aluminum Rigging Frame, P/N: 140-137102-XX), using the four mounting points on the underside of the projector.



**Warning!** If not avoided, the following could result in death or serious injury.

- When not mounted properly, the projector may fall.
- The warranty on this projector does not cover damage caused by the use of a non-recommended ceiling mount kit or installation of the ceiling mount kit in an improper location.

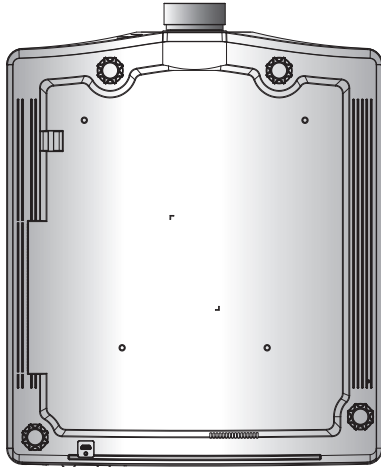

Refer to the installation instructions and safety guidelines provided in the kit (such as Christie One Mount Plus, P/N: 140-117100-XX, or Christie One Aluminum Rigging Frame, P/N: 140-137102-XX).

## Leveling the projector

To adjust the vertical position of the projector, turn in or out of the adjustable feet on the bottom of the projector.

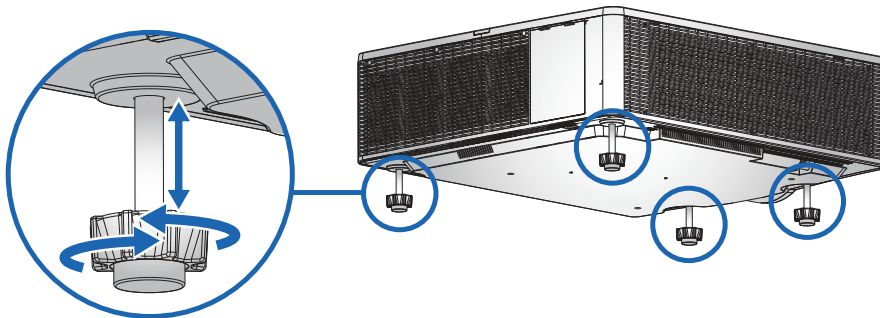

## Installing the projector lens



**Warning!** If not avoided, the following could result in death or serious injury.

- Turn off the projector and remove the power cord, before installing or replacing a lens.

Only use the lens compatible with Christie HS Series D16-20 projectors.

1. Remove the dust cover from the lens opening.
2. Release the screw on the lens release button with an M2.5 Allen key.

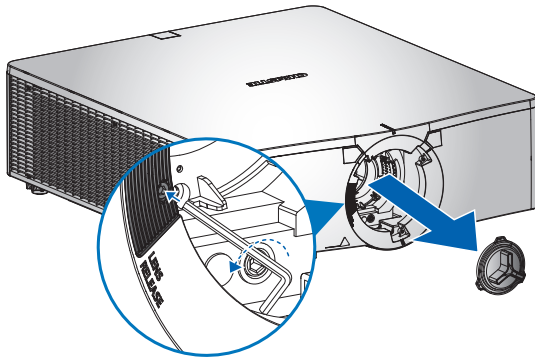

3. Align the top of the lens with the red marker on front cover.

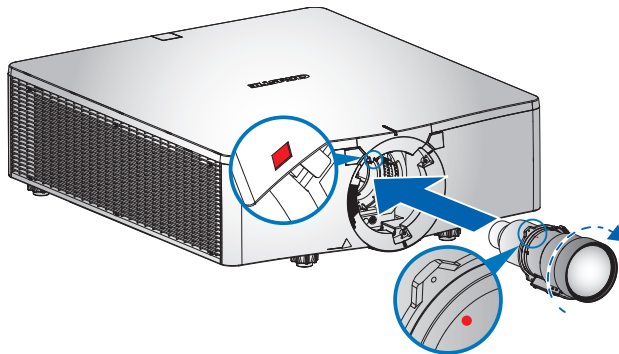

4. Insert the lens into the projector and turn it clockwise until you hear a clicking sound.



- When handling the projector after lens installation, make sure the front lens cap is placed on the lens to protect the lens surface from potential damage.
- When carrying or moving the projector, do not handle by the lens. This may damage the lens, the chassis, or other mechanical parts within the projector.

## Calibrating the lens motor

Ensure then lens motor is calibrated before using the projector. Failure to calibrate the lens motor properly may cause following implications.

- Inability to use the full range of the lens motor.
- Lens motor traveling beyond the lens shifting range.
- Damage to the projector.

Calibrate the lens motors when any of the following conditions are met:

- After a lens change.
- After the projector is moved.
- After any manual adjustment made to the zoom or focus.

To calibrate the lens motor:

1. Press **OSD**.
2. Select **Menu > Configuration > Lens Settings > Lens Calibration**.
3. Press **ENTER**.

## Removing the projector lens

To safely remove the projection lens, complete the following steps.

1. Center the lens while the projector is switched on by pressing the **LENS H** or **LENS V** button and then pressing **ENTER**.

Ensure the lens is at or near its center position. Attempting to remove the lens with a large offset may cause damage to the lens assembly.

2. Turn off the projector.
3. Allow the projector to cool down into standby mode before replacing the lens.
4. After the projector has cooled down and prior to replacing the lens, remove the power cord.
5. Push in and hold the lens release button.
6. Turn the lens counterclockwise by a quarter to release the lens.
7. Gently pull the lens out of the lens holder.

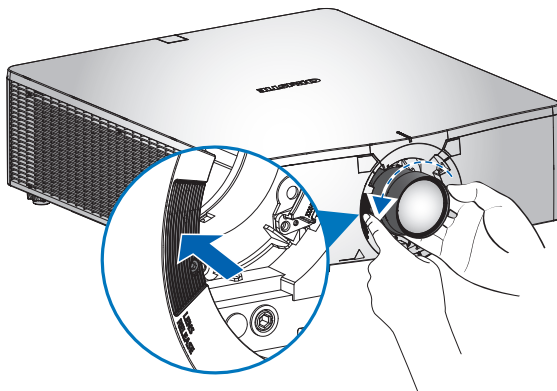

Christie recommends covering the lens opening with the dust cover to prevent damage to the projector.

## Removing and installing the fuse

To remove and install the fuse, complete the following steps.

1. Turn the projector off.
2. Remove the screw on the fuse with a flat-head screwdriver.
3. Remove the fuse and replace it with the new one.

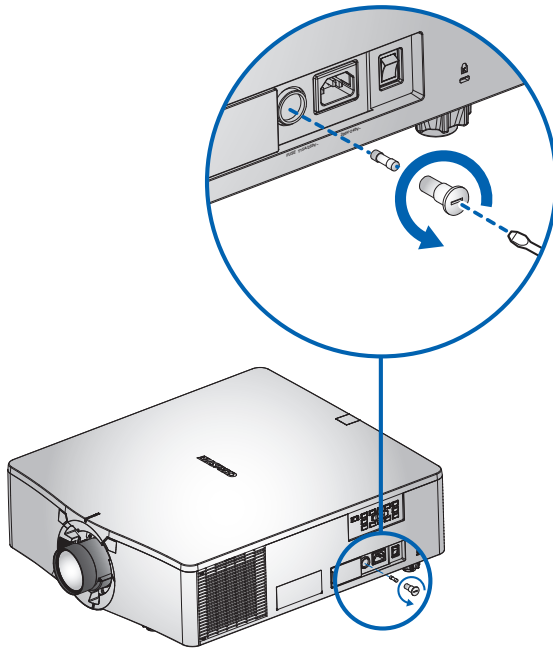



## Cleaning or installing the filter

Regularly clean or replace the filters in the projector to ensure dust and other foreign materials are kept out of the projector.

1. Turn off the projector.
2. Remove the screws on the filter cover using a 3 mm hex key.

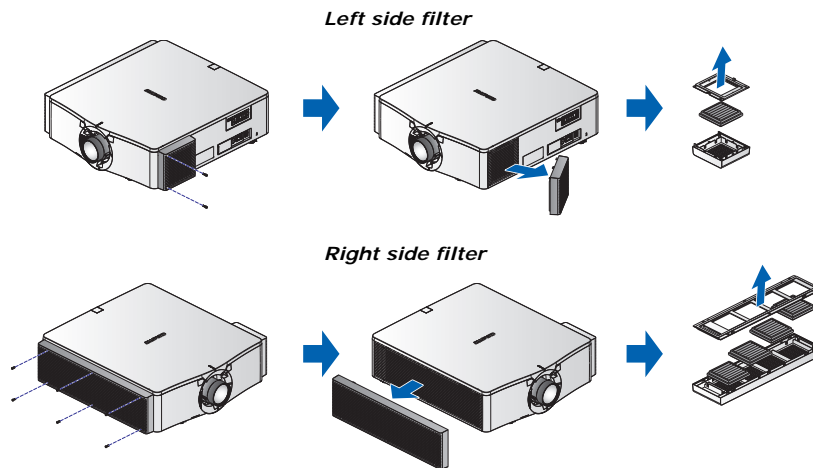

3. Remove the filter cover.
4. Remove the filter from its compartment.
5. Clean or replace the filter.

Fog filters should be replaced after each use of the projector to a maximum of 20 hours. The life of the filter is approximately 20 hours based on environmental conditions. Leave the filters in their sealed packaging until ready for use.



Do not re-use the fog filters as they clog up with oil and the projector overheats and shuts down.

## Connecting to AC power

To operate the projector at full brightness, make sure the power supply meets the power requirements for HS Series D16-20 projectors. See [Power connection](#) on page 14 for more information.

Model name	Power requirements
D20WU-HS/D20HD-HS	200-240 VAC, 50/60 Hz, 9 A
D16WU-HS/D16HD-HS	120-240 VAC, 50/60 Hz, 12 A 200-240 VAC, 50/60 Hz, 7 A (rated for China, India, Taiwan, and Korea) 200 VAC, 50/60 Hz, 7 A, 1250 W (rated for Japan)



For more information detailing the power requirements, refer to the *HS Series D16-20 Specification Guide* (P/N: 020-001467-XX).

To ensure safe operation, only use the AC power cord provided with the product or recommended by Christie. Connect the AC power cord to the AC inlet on the projector.

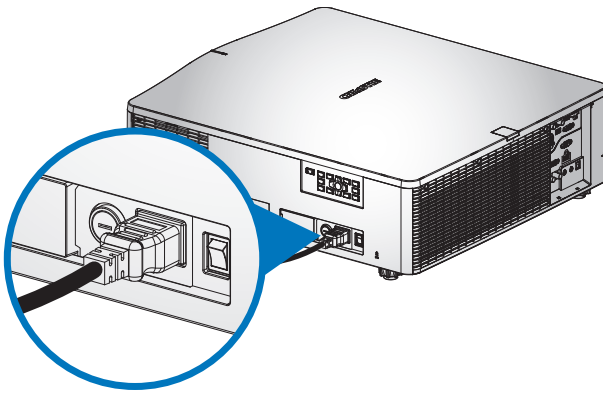

## Turning on the projector

The projector cables must be securely connected before turning the power on.



**Warning!** If not avoided, the following could result in death or serious injury.

- Do not look into the projector lens when the laser is on. The bright light may result in permanent eye damage.

1. Plug the projector in to AC power.

The Power button on the built in keypad is illuminated when the power cables are connected.

2. Ensure the lens has been installed in the projector by a Christie qualified service technician.



**Warning!** If not avoided, the following could result in death or serious injury.

- Installing or replacing a lens must be done by a Christie qualified service technician to avoid exposure to dangerous emission levels.

3. Ensure that no one or no objects are in the beam path before turning on the projector.

4. To turn on the projector, on the IR remote keypad or on the built-in keypad press .

The status LED is green with a long blink.

5. To select an input source and turn it on, on the IR remote keypad select **INPUT**.

Available input sources are VGA, HDMI1, HDMI2, DVI, 3G-SDI, and HDBaseT.

The projector detects the source you selected and displays the image.

6. If using the projector for the first time, select a preferred language from the Main Menu after the startup screen is displayed.

## Turning off the projector

Power off the projector in preparation for inspection or maintenance.

1. To turn the projector off, on the IR remote keypad or built-in keypad press .

A warning message appears on the displayed image.

2. To confirm your selection, press  again.

If you do not press  again, the warning message disappears after three seconds and the projector remains on.

## LED status indicator

LED status indicator helps identify the projector state. LEDs are defined below.

### Status LED

Identify the LED state colors and meaning.

LED status	Projector state
Off	AC power is off (without AC plugged in).
Green (flashing)	Projector is starting up.
Green (solid)	System is operating normally.
Blue (flashing)	Projector is cooling down.
Blue (solid)	Projector is in standby mode.
Yellow (flashing)	A problem exists with the projector that does not cause it to shut down. Examples of warnings include: filter needs changing, one of the pumps is damaged, or a fan is operating at full speed due to over temperature of laser diode (LD) driver.
Yellow (solid)	The end user is turning off the projector while it is in a warning state.
Red (flashing)	An error with the projector exists causing it to shut down. Examples of errors include: fan failure, over temperature, wrongly installed filter, or color wheel (CW) failure.
Red (solid)	The user is turning off the projector while it is in an error state.
White (flashing)	Projector is in a flash (LAN) update state.

### Shutter LED

Identify the shutter LED state colors and meaning.

LED Status	Projector State
Off	Projector is on and an image is displayed. Shutter is open.
Magenta (solid)	Projector is on and the image is blank. Shutter is closed.

## Calculating the lens offset

Adjust the offset to align the image on the screen with half image size.

- The vertical image offset (shift) range for the projector is up to +/-120% (WUXGA) and +/-140% (HD).
- The horizontal image offset (shift) range for the projector is up to +/-50% (HD/WUXGA).
- The method for calculating lens offset complies with industry standards, with which the image offset is calculated by half image size. For example for Vertical lens offset:
  - At 0% offset (or on axis), the center of the image is on the lens center, so half of the image appears above and half appears below the lens center.
  - At +100% offset, all of the image appears above the lens center.

The following show the vertical and horizontal image offsets for the HS Series D16-20 projectors:

- Vertical image offset: 0%

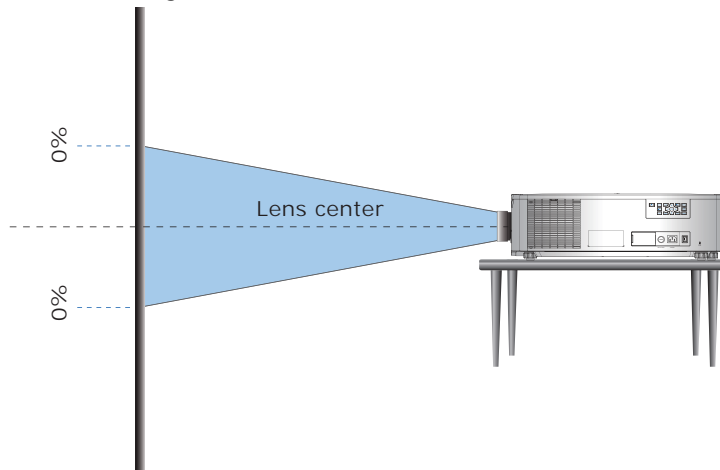

- WUXGA Vertical image offset: +/-120%

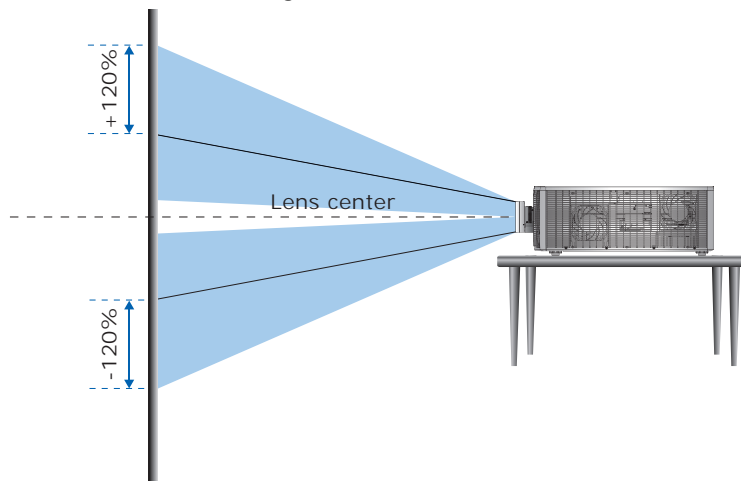

- HD Vertical image offset: +/-140%

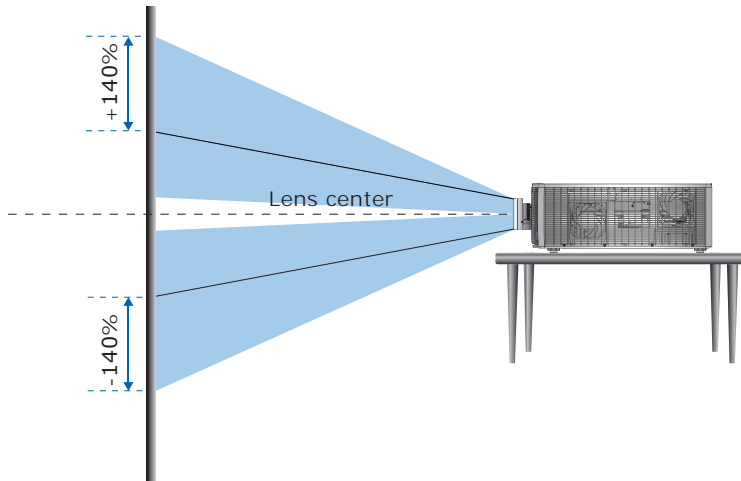

- Horizontal image offset: +/-50%

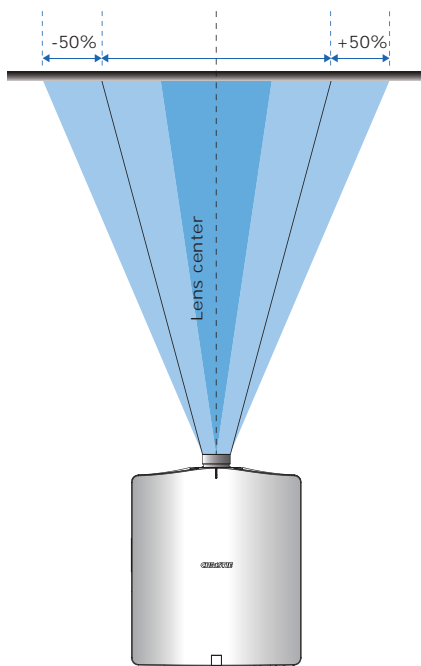

## Adjusting boresight

The boresight adjustment turns the lens holder to remove the tilt between the lens and DMD to make the image clear, crisp, and sharp. To perform boresight adjustment, use an M4 Allen key to adjust the three boresight set screws on the lens holder.

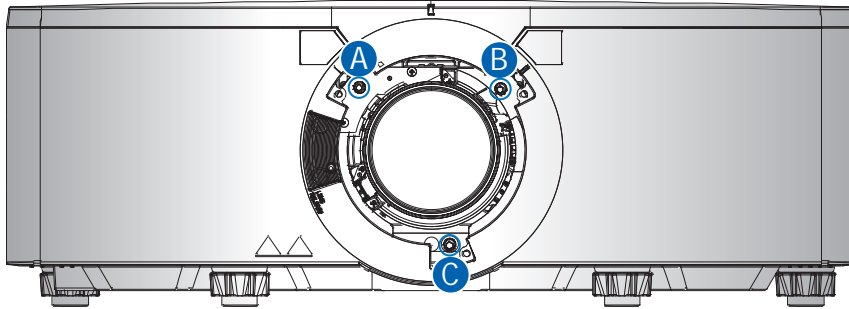

Items	Description
A, B, C	Boresight set screws <ul style="list-style-type: none"> <li>To tighten the set screws, turn counterclockwise.</li> <li>To loosen the set screws, turn clockwise.</li> </ul>

To perform boresight adjustment, complete the following steps:

1. Project a focus test pattern.

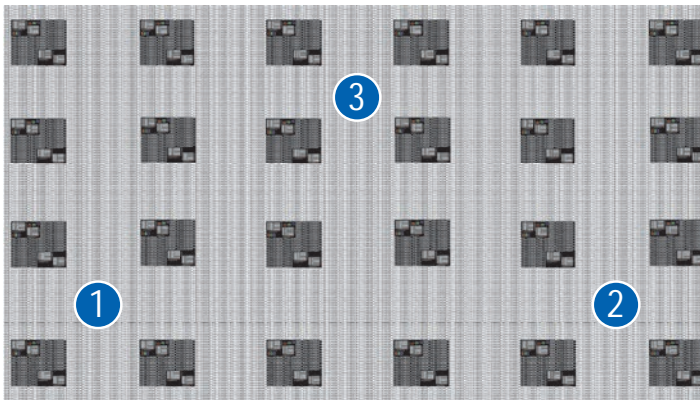

2. To optimize the focus of position 1 on the screen, press **FOCUS ▲** or **▼** key.
3. Once position 1 is in focus, check position 2. If position 2 is not in focus, use the **FOCUS ▲** or **▼** key to bring position 2 into focus on the screen.
  - If pressing **FOCUS ▲** key results in position 2 coming into focus, turn set screw A clockwise.
  - If pressing **FOCUS ▼** key results in position 2 coming into focus, turn set screw A counterclockwise.

4. Refocus position 1 and check if position 2 is also in focus. If not, repeat step 3 and 4 until both position 1 and 2 are in focus.
5. To optimize the focus of position 3 on the screen, turn set screw C clockwise or counterclockwise.
6. Repeat from step 2 until the projected focus pattern is as sharp as possible in the center, left, right, top, and bottom of the screen.
7. If the projector is still not in focus, reset the set screw position:
  - a. Turn the set screws counterclockwise until tight.
  - b. Turn the set screws 1.5 turns in the clockwise direction back to their factory default setting.
  - c. Check that the alignment of the set screws matches what is shown in the image above.



# Connecting to devices

This section covers the information on connecting the HS Series D16-20 projector to a computer and video equipment.

## Connecting to a computer

Learn what cables/connectors can be used to connect to various devices.

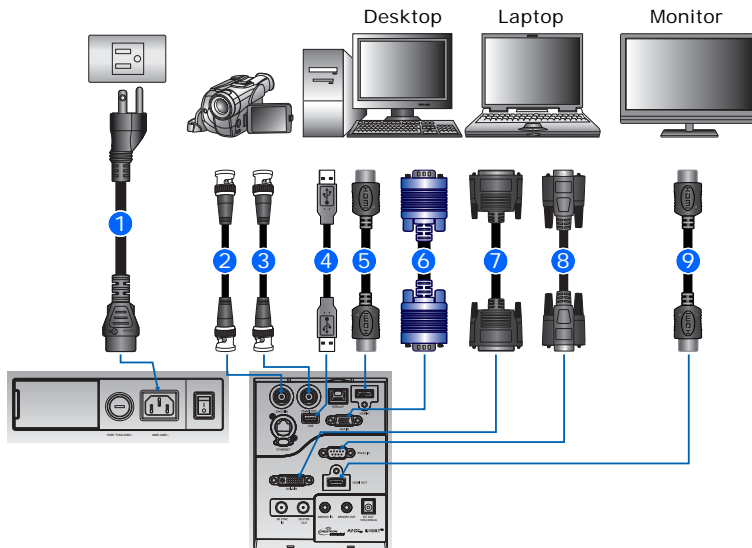

ID	Connector name	ID	Connector name
1	Power cord	6	VGA in cable
2	3G-SDI in with BNC cable + camcorder	7	DVI-D in cable
3	3G-SDI out with BNC cable + camcorder	8	RS232 cable
4	USB type A cable	9	HDMI cable
5	HDMI cable		

# Connecting to video equipment

Learn what cable/connectors may be used to connect to various video sources.

Component video output equipment    DVD player    Video cassette recorder

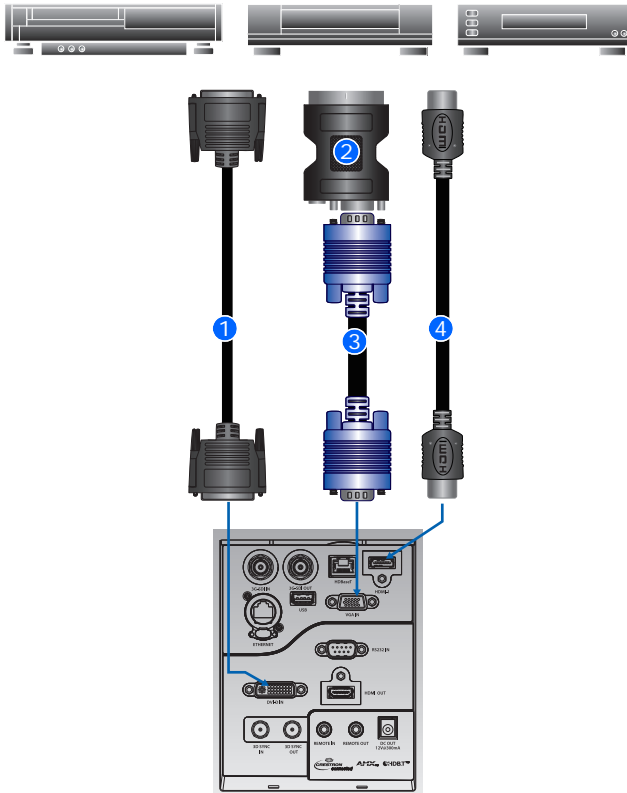

ID	Connector name	ID	Connector name
1	DVI-D in cable	3	VGA in cable
2	VGA to component	4	HDMI cable



- After connecting the projector to an input device, the projector automatically detects the input source. You can also select an input source by pressing **INPUT**.
- Due to the difference in applications for each country, the accessories required in some regions may differ from those shown.
- The diagrams are for illustrative purposes only and do not indicate that these accessories are supplied with the projector.

# Signal connectivity specifications

Identify the signal connectivity specifications for HS Series D16-20 projector.

## Inputs

The list of formats listed below are not exhaustive and other formats may be supported. For more information, contact Christie Technical Support.

Signal Type	Resolution	Frame rate (Hz)	VGA	HDMI 1	HDMI 2	DVI	SG-SDI	HDBaseT
PC	640x480	60	•	•	•	•		•
	640x480	72	•	•	•	•		•
	640x480	75	•	•	•	•		•
	640x480	85	•	•	•	•		•
	640x480	66.6		•	•	•		•
	720x400	70	•	•	•	•		•
	800x600	60	•	•	•	•		•
	800x600	72	•	•	•	•		•
	800x600	75	•	•	•	•		•
	800x600	85	•	•	•	•		•
	800x600	120	•	•	•	•		•
	832x624	75	•	•	•	•		•
	848x480	50		•	•	•		•
	848x480	60		•	•	•		•
	848x480	75		•	•	•		•
	848x480	85		•	•	•		•
	1024x768	60	•	•	•	•		•
	1024x768	75	•	•	•	•		•

Signal Type	Resolution	Frame rate (Hz)	VGA	HDMI 1	HDMI 2	DVI	SG-SDI	HDBaseT
PC	1024x768	85	•	•	•	•		•
	1024x768	120	•	•	•	•		•
	1152x720	50		•	•	•		•
	1152x720	60		•	•	•		•
	1152x720	75		•	•	•		•
	1152x720	85		•	•	•		•
	1152x864	60	•	•	•	•		•
	1152x864	70	•	•	•	•		•
	1152x864	75	•	•	•	•		•
	1152x864	85	•	•	•	•		•
	1152x870	75		•	•	•		•
	1280x720	50		•	•	•		•
	1280x720	60	•	•	•	•		•
	1280x720	75	•	•	•	•		•
	1280x720	85	•	•	•	•		•
	1280x720	120	•	•	•	•		•
	1280x768	60	•	•	•	•		•
	1280x768	75	•	•	•	•		•
	1280x768	85	•	•	•	•		•
	1280x800	50	•	•	•	•		•
	1280x800	60	•	•	•	•		•
	1280x800	75	•	•	•	•		•
	1280x800	85	•	•	•	•		•
	1280x960	50		•	•	•		•
	1280x960	60	•	•	•	•		•
	1280x960	75	•	•	•	•		•
	1280x960	85	•	•	•	•		•
	1280x1024	50		•	•	•		•
	1280x1024	60	•	•	•	•		•
	1280x1024	75	•	•	•	•		•
	1280x1024	85	•	•	•	•		•
	1360x768	50		•	•	•		•
	1360x768	60		•	•	•		•
1360x768	75		•	•	•		•	

Signal Type	Resolution	Frame rate (Hz)	VGA	HDMI 1	HDMI 2	DVI	SG-SDI	HDBaseT
PC	1360x768	85		•	•	•		•
	1366x768	60	•	•	•	•		•
	1400x1050	50		•	•	•		•
	1400x1050	60		•	•	•		•
	1400x1050	75	•	•	•	•		•
	1440x900	60	•	•	•	•		•
	1440x900	75		•	•	•		•
	1600x900	60		•	•	•		•
	1600x1200	60	•	•	•	•		•
	1680x1050	60	•	•	•	•		•
	1920X1080	50		•	•	•		•
	1920X1080	60	•	•	•	•		•
	1920X1200RB	60	•	•	•	•		•
	1920X1200RB	50	•	•	•	•		•
SDTV	480i	60	•	•	•	•		•
	576i	50	•	•	•	•		•
EDTV	480p	60	•	•	•	•		•
	576p	50	•	•	•	•		•
HDTV	1080i	25	•	•	•	•		•
	1080i	29	•	•	•	•		•
	1080i	30	•	•	•	•		•
	720p	50	•	•	•	•		•
	720p	59	•	•	•	•		•
	720p	60	•	•	•	•		•
	1080p	23	•	•	•	•		•
	1080p	24	•	•	•	•		•
	1080p	25	•	•	•	•		•
	1080p	29	•	•	•	•		•
	1080p	30	•	•	•	•		•
	1080p	50	•	•	•	•		•
	1080p	59	•	•	•	•		•
1080p	60	•	•	•	•		•	
Mandatory 3D	Frame Packing 1080p	24		•	•	•		•

Signal Type	Resolution	Frame rate (Hz)	VGA	HDMI 1	HDMI 2	DVI	SG-SDI	HDBaseT
Mandatory 3D	Frame Packing 720p	50		•	•	•		•
	Frame Packing 720p	60		•	•	•		•
	Side by Side 1080i	50		•	•	•		•
	Side by Side 1080i	60		•	•	•		•
	Top and Bottom 720p	50		•	•	•		•
	Top and Bottom 720p	60		•	•	•		•
	Top and Bottom 1080p	24		•	•	•		•
Frame sequential 3D	800x600	120		•	•	•		•
	1024x768	120		•	•	•		•
	1280x720	120		•	•	•		•
	1080p	120		•	•	•		•
	1080p	60		•	•	•		•
	WUXGA	60		•	•	•		•
SD-SDI	480i YcbCr422 10bit	59.94					•	
	576i YcbCr422 10bit	50					•	
HD-SDI	720p YcbCr422 10bit	50, 59.94, 60					•	
	1080i YcbCr422 10bit	50, 59.94, 60					•	
	1080p YcbCr422 10bit	23.98, 24, 25, 29.97, 30					•	
	1080sF YcbCr422 10bit	25, 29.97, 30					•	
3GA-SDI	1080p YcbCr422 10bit	50, 59.94, 60					•	

Signal Type	Resolution	Frame rate (Hz)	VGA	HDMI 1	HDMI 2	DVI	3G-SDI	HDBaseT
3GB-SDI	1080p YcbCr422 10bit With 352M Payload ID	50, 59.94, 60					•	
4K	3840x2160	23.976		•	•	•		•
		24		•	•	•		•
		25		•	•	•		•
		29.970		•	•	•		•
		30		•	•	•		•
		50		•	•	•		
		59.940		•	•	•		
		60		•	•	•		
	4096x2160	23.976		•	•	•		•
		24		•	•	•		•
		25		•	•	•		•
		29.970		•	•	•		•
		30		•	•	•		•
		50		•	•	•		
		59.940		•	•	•		
		60		•	•	•		

## Picture-in-picture/picture-by-picture (PIP/PBP) compatibility

The following table details the picture-in-picture/picture-by-picture (PIP/PBP) compatibility.

PIP/PBP Matrix	VGA	DVI	HDMI 1	HDMI 2	3G-SDI	HDBaseT
VGA		•	•	•	•	•
DVI	•		•	•	•	•
HDMI 1	•	•		•	•	•
HDMI 2	•	•	•		•	•
3G-SDI	•	•	•	•		•
HDBaseT	•	•	•	•	•	

- Dot (•): PIP/PBP combinations are enabled.
- Dash (-): PIP/PBP combinations are disabled.

# Regulatory

This product conforms to the following regulations related to product safety, environmental requirements and electromagnetic compatibility (EMC).

## Safety

- CAN/CSA C22.2 No. 60950-1-07 – Information Technology Equipment – Safety – Part 1: General Requirements
- ANSI/UL 60950-1-2014 – Information Technology Equipment – Safety – Part 1: General Requirements
- IEC/EN 60950-1 – Information Technology Equipment – Safety – Part 1: General Requirements

## Laser safety

- IEC 60825-1 – Safety of Laser Products – Part 1: Equipment Classification and Requirements
- IEC 62471-1 – Photobiological safety of lamps and lamp systems
- IEC/EN 62471-5 - Photobiological safety of lamps and lamp systems – Part 5: Image projectors
- FDA CDRH 21CFR 1040 - Performance Standards For Light-Emitting Products

## Electro-magnetic compatibility

### Emissions

- FCC CFR47, Part 15, Subpart B, Class A - Unintentional Radiators
- CAN ICES-3 (A/B) / NMB-3 (A) - Information Technology Equipment (Including Digital Apparatus)
- CISPR 32:2014/EN 55032:2014, Class A - Information Technology Equipment
- IEC 61000-3-2/EN61000-3-2 - Limits for Harmonic Current Emissions
- IEC 61000-3-3/EN61000-3-3 - Limitations of Voltage Changes, Voltage Fluctuations, and Flicker



## Immunity

- CISPR 24/EN55024 EMC Requirements - Information Technology Equipment

## Environmental

- EU Directive (2011/65/EU) on the restriction of the uses of certain hazardous substances (RoHS) in electrical and electronic equipment and the applicable official amendment(s)
- EU Directive (2012/19/EU) on waste and electrical and electronic equipment (WEEE) and the applicable official amendment(s)
- Regulation (EC) No 1907/2006 concerning the Registration, Evaluation, Authorization and Restriction of Chemicals (REACH) and the applicable official amendment(s)
- China Ministry of Information Industry Order No.39 (02/2006) on the control of pollution caused by electronic information products, hazardous substances concentration limits (SJ/T11363-2006), and the applicable product marking requirement (SJ/T11364-2006)

## Corporate offices

---

Christie Digital Systems USA, Inc.  
Cypress  
ph: 714 236 8610

Christie Digital Systems Canada Inc.  
Kitchener  
ph: 519 744 8005

## Worldwide offices

---

Australia  
ph: +61 (0) 7 3624 4888

Brazil  
ph: +55 (11) 2548 4753

China (Beijing)  
ph: +86 10 6561 0240

China (Shanghai)  
ph: +86 21 6278 7708

France  
ph: +33 (0) 1 41 21 44 04

Germany  
ph: +49 2161 664540

India  
ph: +91 (080) 6708 9999

Japan (Tokyo)  
ph: 81 3 3599 7481

Korea (Seoul)  
ph: +82 2 702 1601

Mexico  
ph: +52 55 4744 1790

Republic of South Africa  
ph: +27 (0)11 510 0094

Russian Federation  
and Eastern Europe  
ph: +36 (0) 1 47 48 100

Singapore  
ph: +65 6877 8737

Spain  
ph: +34 91 633 9990

United Arab Emirates  
ph: +971 4 3206688

United Kingdom  
ph: +44 (0) 118 977 8000

United States (Arizona)  
ph: 602 943 5700

United States (New York)  
ph: 646 779 2014

## Independant sales consultant offices

Italy  
ph: +39 (0) 2 9902 1161



For the most current technical documentation, visit [www.christiedigital.com](http://www.christiedigital.com).

