

LENS PN	DESCRIPTION	DIMENSION 'A'	DIMENSION 'B'	DIMENSION 'C'	DIMENSION 'D'	DIMENSION 'E'	DIMENSION 'F'
140-114107-XX	Optional Lens (TR: 0.84-1.02)	47.0 (1.9")	107.0 (4.2")	721.0 (28.4")	335 (13.2")	298 (11.7")	80 (3.1")
140-115108-XX	Optional Lens (TR: 1.02-1.36)	1.0 (0.1")	60.0 (2.4")	674.0 (26.5")	340 (13.4")	298 (11.7")	80 (3.1")
140-109101-XX	Optional Lens (TR: 1.20-1.50)	51.0 (2.0")	111.0 (4.4")	725.0 (28.6")	339 (13.3")	298 (11.7")	80 (3.1")
140-110103-XX	Standard Lens (TR: 1.50-2.00)	36.0 (1.4")	96.0 (3.8")	710.0 (27.9")	339 (13.3")	298 (11.7")	80 (3.1")
140-111104-XX	Optional Lens (TR: 2.0-4.00)	71.0 (2.8")	131.0 (5.2")	745.0 (29.3")	330 (13.0")	298 (11.7")	80 (3.1")
140-116109-XX	Optional Lens (TR: 4.00-7.20)	95.0 (3.7")	155.0 (6.1")	769.0 (30.3")	333 (14.4")	298 (11.7")	80 (3.1")

REVISION HISTORY OF: 020-001429-01			
REV	DESCRIPTION OF CHANGE	BY	REV DATE
01	INITIAL RELEASE	WAYNE	07/2018
02	CORRECT BTD LENS AND OPERATING TEMPERATURE	WAYNE	12/20/2018
03	UPDATE POWER CONSUMPTION AND CORRECT AIR FLOW CLEARANCE	WAYNE	01/17/2019

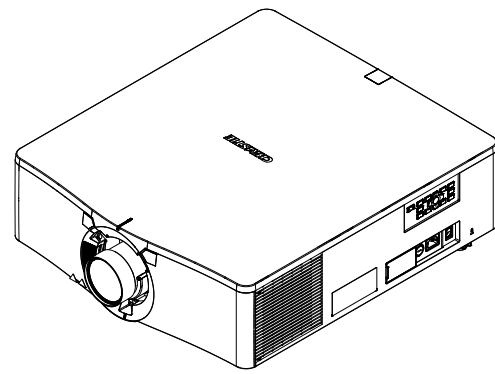
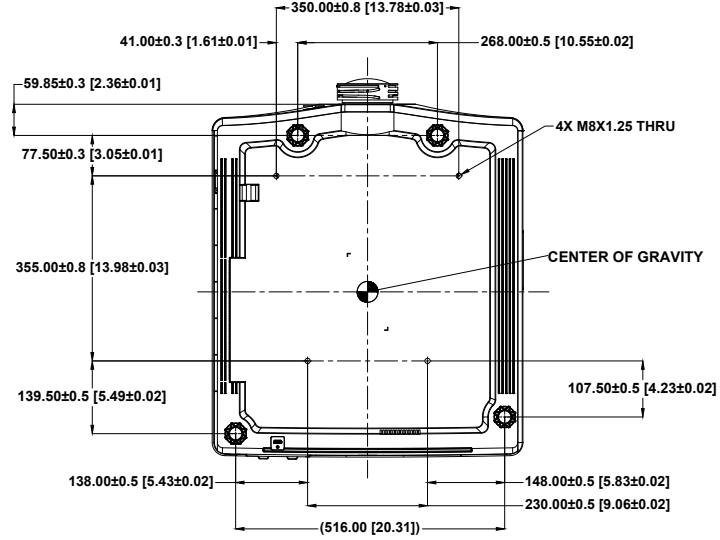
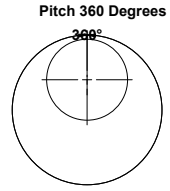
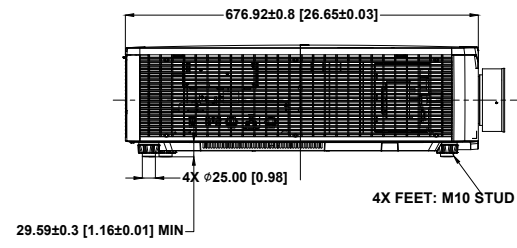
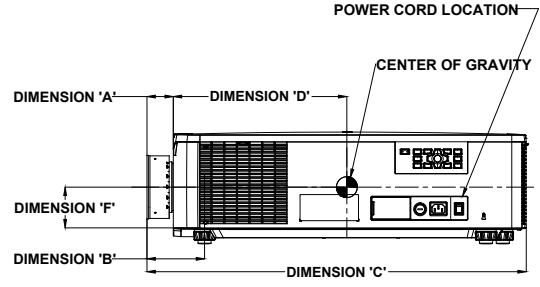
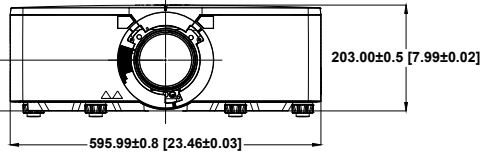
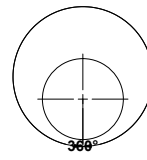
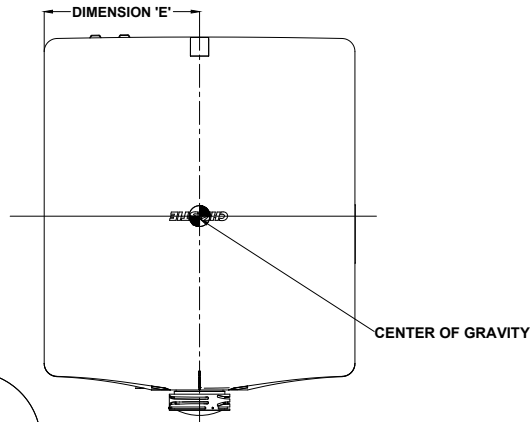

GENERAL NOTES:
MASS: 41.6 kg (91.7 lbs) NO LENS
OPERATING TEMPERATURE RANGE:
 0°C - 40°C (41°F - 104°F) @ 0-2500 FT
 0°C - 35°C (41°F - 95°F) @ 2500-5000 FT
 0°C - 30°C (41°F - 86°F) @ 5000-10000 FT
POWER REQUIREMENTS:
D20XX-HS:
 INPUT: 200-240V~, 9A, 50/60 HZ
 POWER CONSUMPTION: 1710W (MAX)
 (BTU: 1W = 3.41 BTU/hr)
D16XX-HS:
 INPUT: 120-240V~, 12A, 50/60 HZ
 POWER CONSUMPTION: 1410W (MAX)
 (BTU: 1W = 3.41 BTU/hr)

[INPUT / OUTPUT PANEL]

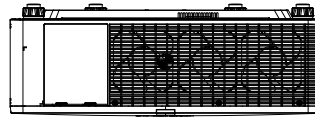
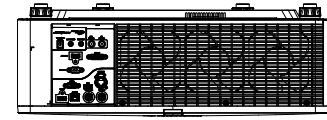

DESCRIPTION	DIMENSION 'D'	DIMENSION 'E'	DIMENSION 'F'
NO LENS	365 (14.4")	298 (11.7")	77 (3.0")

UNITS: INCHES [] MILLIMETERS [X]	DESIGNED BY: []	DATE: []	CHRISTIE DIGITAL SYSTEMS USA, INC. CANADA, INC.
UNLESS OTHERWISE SPECIFIED TOLERANCES UNLESS OTHERWISE SPECIFIED: DIMENSIONS: FRACTIONS DECIMALS FRACTIONS DECIMALS	DRAWN BY: []	DATE: []	
TOLERANCES APPLY AS SHOWN BELOW:		THIRD ANGLE PROJECTION	
XX	± .003	± .15	DWG LINE D20/D16XX-HS SERIES
XX	± .001	± .05	
XX	± .001	± .05	020-001429-01
XX	± .001	± .05	03

NOTES:
1. PROJECTOR WITH FOG ASSY

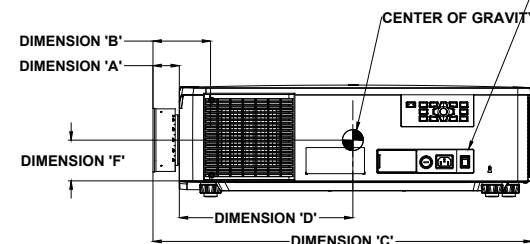
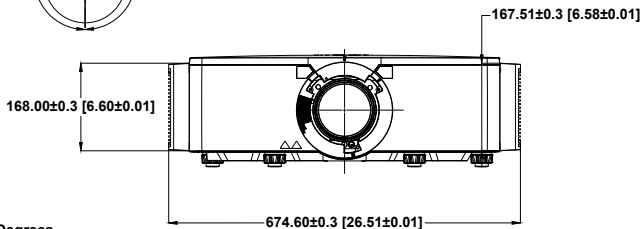
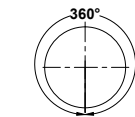
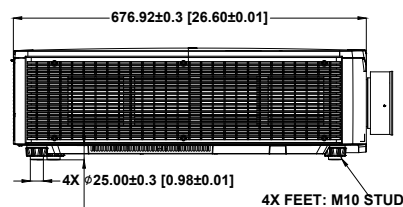
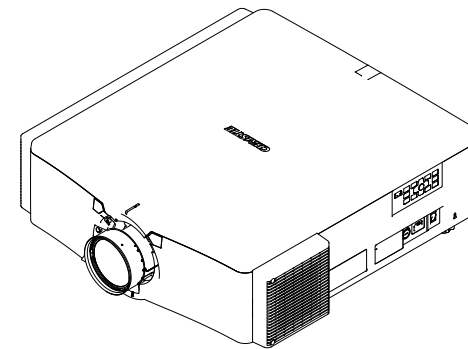
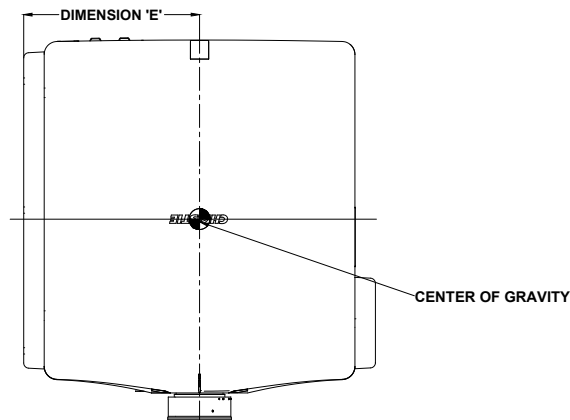

29.59±0.3 [1.16±0.01] MIN

Roll 360 Degrees

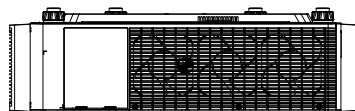
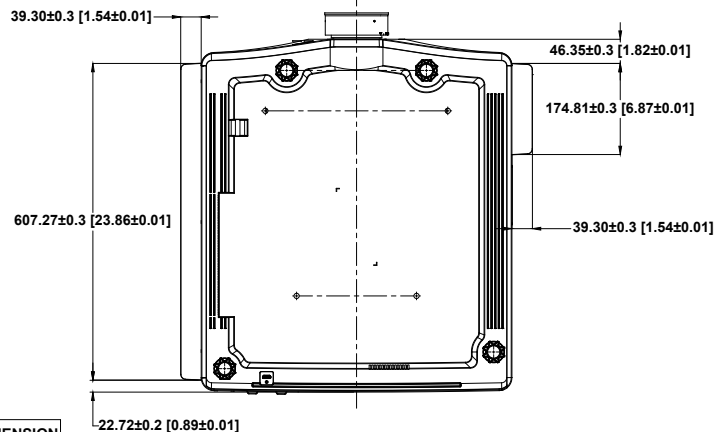
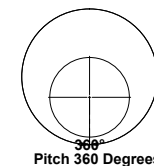

LENS PN	DESCRIPTION	DIMENSION 'A'	DIMENSION 'B'	DIMENSION 'C'	DIMENSION 'D'	DIMENSION 'E'	DIMENSION 'F'
140-114107-XX	Optional Lens (TR: 0.84-1.02)	47.0 (1.9")	107.0 (4.2")	721.0 (28.4")	340 (13.4")	337 (13.3")	80 (3.1")
140-115108-XX	Optional Lens (TR: 1.02-1.36)	1.0 (0.1")	60.0 (2.4")	674.0 (26.5")	345 (13.6")	337 (13.3")	80 (3.1")
140-109101-XX	Optional Lens (TR: 1.20-1.50)	51.0 (2.0")	111.0 (4.4")	725.0 (28.6")	344 (13.5")	337 (13.3")	80 (3.1")
140-110103-XX	Standard Lens (TR: 1.50-2.00)	36.0 (1.4")	96.0 (3.8")	710.0 (27.9")	345 (13.6")	337 (13.3")	80 (3.1")
140-111104-XX	Optional Lens (TR: 2.00-4.00)	71.0 (2.8")	131.0 (5.2")	745.0 (29.3")	335 (13.2")	337 (13.3")	80 (3.1")
140-116109-XX	Optional Lens (TR: 4.00-7.20)	95.0 (3.7")	155.0 (6.1")	769.0 (30.3")	339 (13.3")	337 (13.3")	80 (3.1")

DESCRIPTION	DIMENSION 'D'	DIMENSION 'E'	DIMENSION 'F'
NO LENS	371 (14.4")	337 (13.3")	77 (3.0")

NOTES:
1. PROJECTOR WITH FOG ASSY INSTALLED

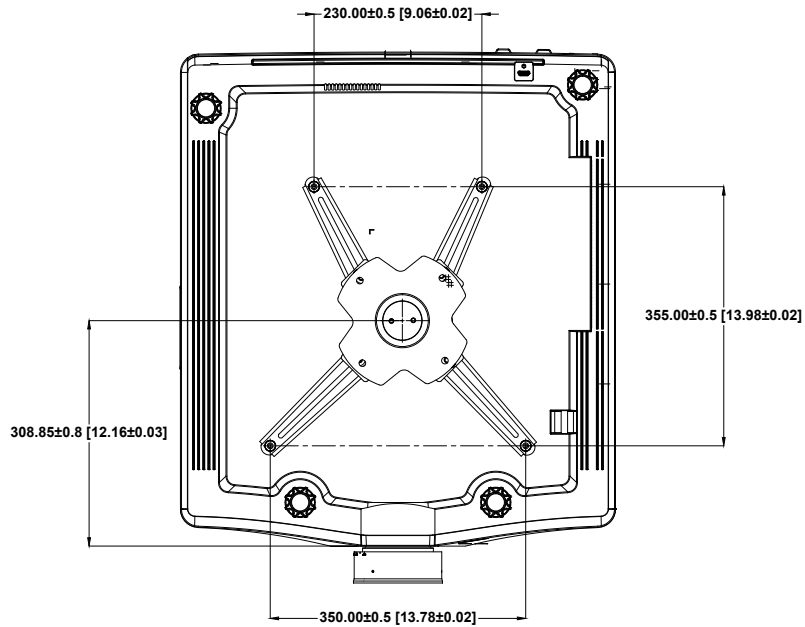

Specification	
Weight Capacity	45 kg (99 lbs)
Maximum Dimension	192 x 192 x 180 mm (7.6 x 7.6 x 7.1 inch)
Tilt Angle	±45°
Swivel	360°
Mass	4.9 kg (10.8 lbs)

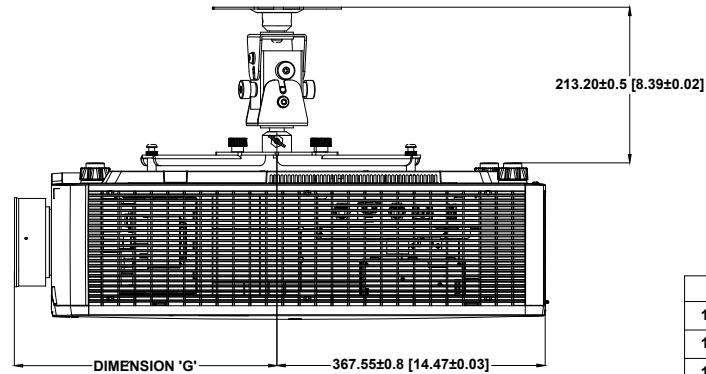
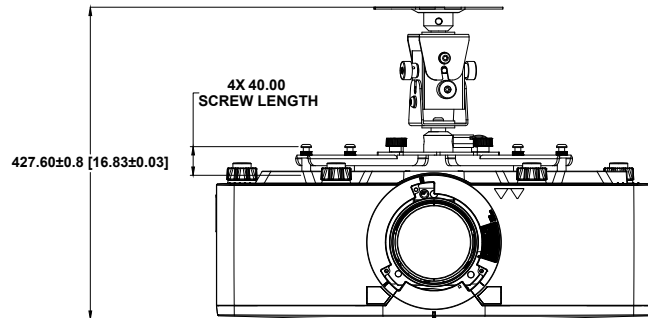
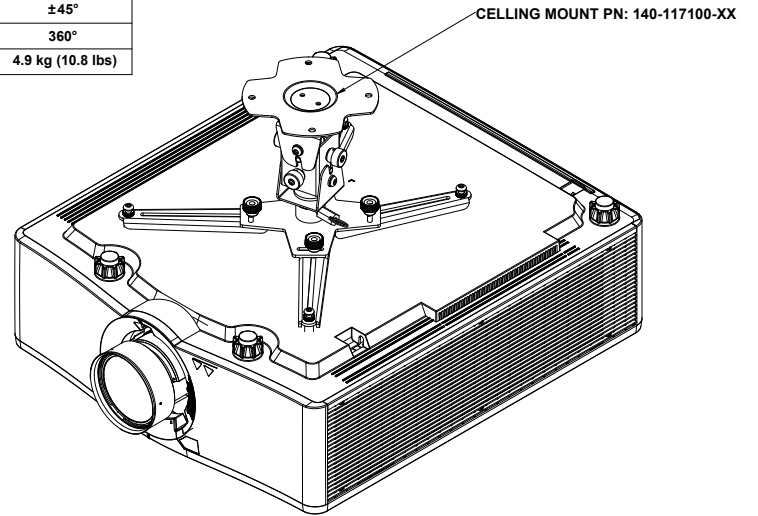

LENS PN	DESCRIPTION	DIMENSION 'G'
140-114107-XX	Optional Lens (TR: 0.84~1.02)	345 (13.59")
140-115108-XX	Optional Lens (TR: 1.02~1.36)	298 (11.75")
140-109101-XX	Optional Lens (TR: 1.20~1.50)	349 (13.73")
140-110103-XX	Standard Lens (TR: 1.50~2.00)	330 (12.98")
140-111104-XX	Optional Lens (TR: 2.00~4.00)	372 (16.64")
140-116109-XX	Optional Lens (TR: 4.00~7.20)	395 (15.53")

PROJECTOR WITH FOG INSTALLED

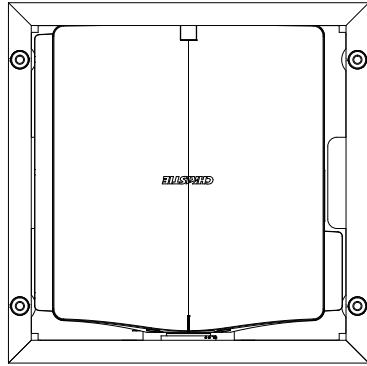

790 [31.10]

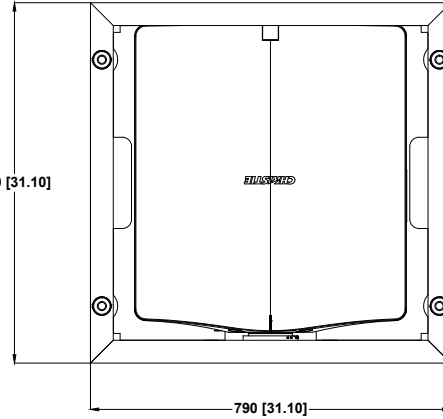

790 [31.10]

Specification

Weight Capacity	45 kg (99 lbs)
Maximum Dimension	790 x 790 x 463 mm (31.1 x 31.1 x 18.2 inch)
Roll	±3°
Pitch	±3°
Yaw	±3°
Mass	40.37 kg (89 lbs)

RIGGING FRAME PN: 140-113106-XX

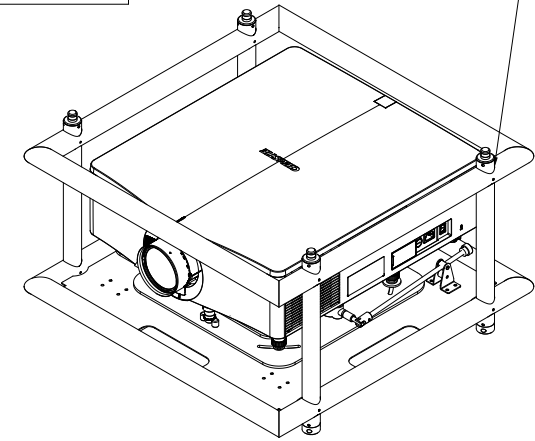

PROJECTOR WITH FOG INSTALLED

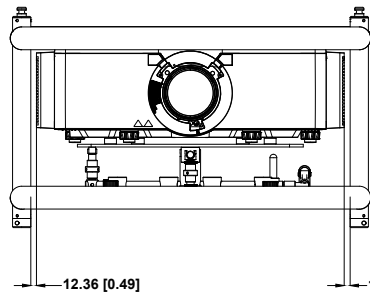

12.36 [0.49]

13.04 [0.51]

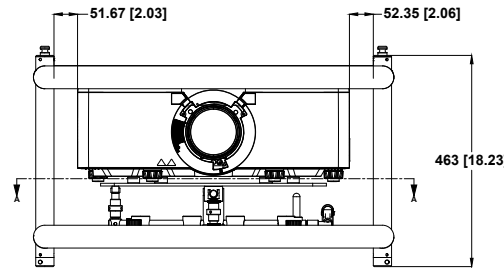

51.67 [2.03]

52.35 [2.06]

463 [18.23]

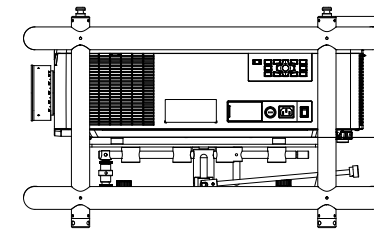

242.27 [9.54] 265.27 [10.44]

4X SPACERS PN:
012-103288-01

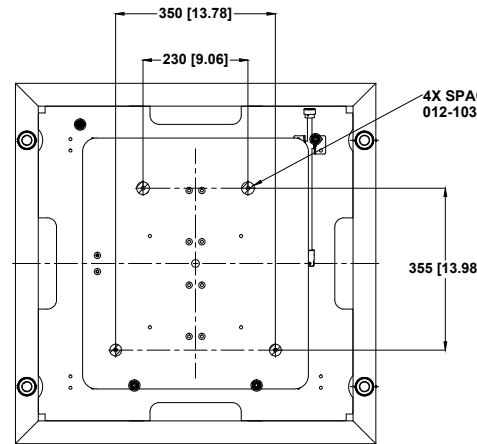

350 [13.78]

230 [9.06]

355 [13.98]

SECTION A-A

Up to three projectors can be stacked in landscape orientation.
A single projector can be positioned in portrait mode - DO NOT STACK.

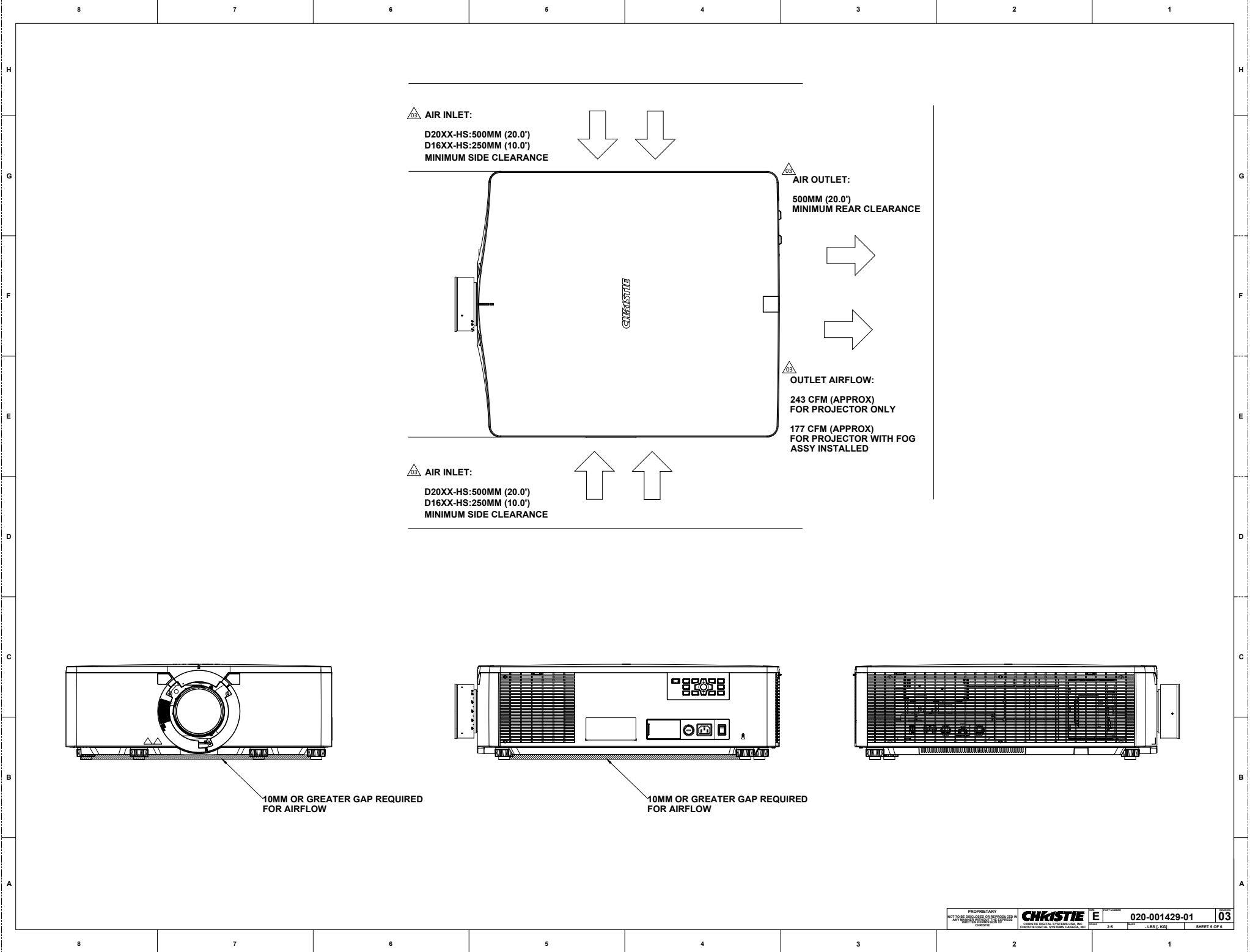

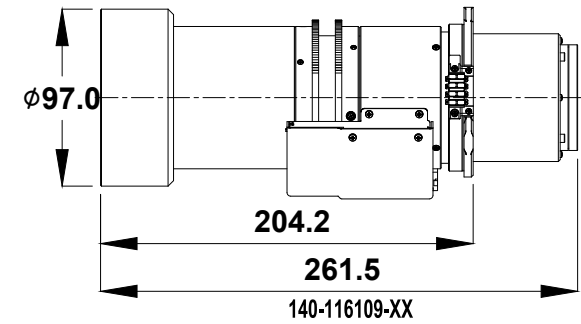
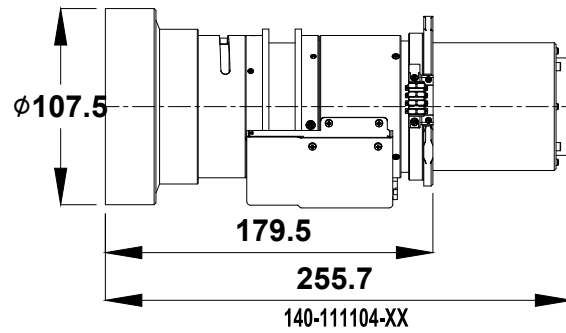
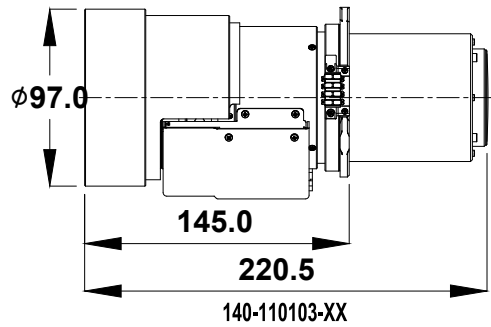
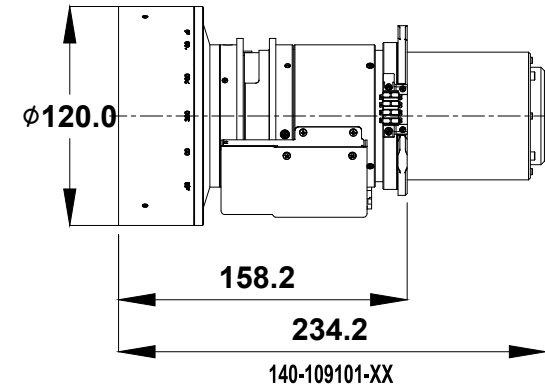
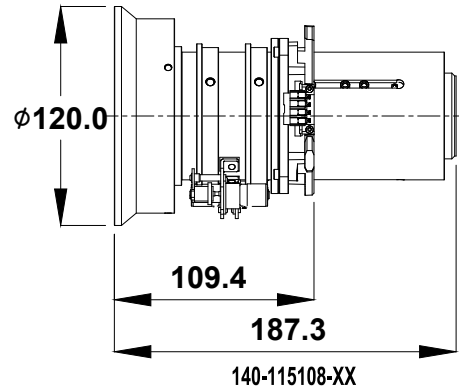
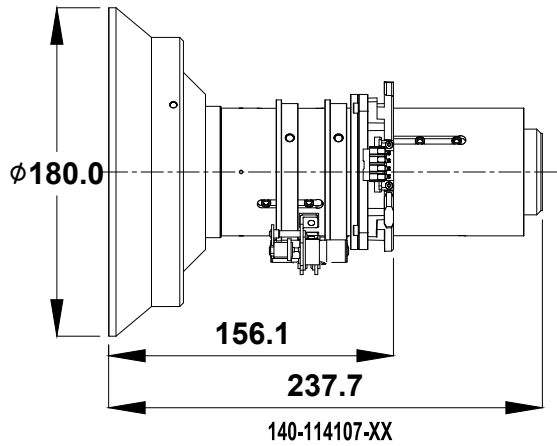

LENS TYPE	DESCRIPTION	NET WEIGHT	GROSS WEIGHT
140-114107-XX	Optional Lens (0.84-1.02)	3.0 KG	3.5 KG
140-115108-XX	Optional Lens (1.02-1.36)	1.8 KG	2.17 KG
140-109101-XX	△ Optional Lens (1.20-1.50)	2.4 KG	2.77 KG
140-110103-XX	△ Standard Lens (1.50-2.00)	2.0 KG	2.39 KG
140-111104-XX	Optional Lens (2.00-4.00)	2.5 KG	2.87 KG
140-116109-XX	Optional Lens (4.00-7.20)	2.4 KG	2.77 KG