

| REV | DESCRIPTION OF CHANGE | BY | REV DATE |
|-----|---|----|------------|
| 01 | INITIAL RELEASE | MO | 07/10/2008 |
| 02 | ADDED CHRISTIE MODEL AND PROJECTION LENSES INFO | MO | 10/17/2008 |
| 03 | ADDED DIMENSION MARKED (SEE SHEET 1) | MO | 11/20/2009 |
| 04 | ADDED CEILING MOUNT SPECIFICATIONS | CB | 11/20/2009 |
| 05 | REMOVED MASS FROM TITLE BLOCK | SI | 11/30/2010 |
| 06 | ADDED LENS MASS TABLE (SEE SHEET 5) | TC | 05/24/2011 |

| LENS | DIMENSION 'E' | DIMENSION 'F' |
|------------------------------------|----------------|---------------|
| SXGA+ 0.73:1 HD 0.67:1 | 206mm [8.11"] | 214mm [8.43"] |
| SXGA+ 1.2:1 HD 1.1:1 | 204mm [8.03"] | 216mm [8.50"] |
| SXGA+ 1.25-1.6:1 HD 1.16-1.49:1 | 207mm [8.15"] | 219mm [8.62"] |
| SXGA+ 1.5-2.0:1 HD 1.4-1.8:1 | 213mm [8.39"] | 207mm [8.15"] |
| SXGA+ 2.0-2.8:1 HD 1.8-2.6:1 | 221mm [8.70"] | 211mm [8.31"] |
| SXGA+ 2.8-4.5:1 HD 2.6-4.1:1 | 216mm [8.50"] | 220mm [8.66"] |
| SXGA+ 4.5-7.5:1 HD 4.1-6.9:1 | 231mm [9.09"] | 213mm [8.39"] |
| SXGA+ 7.5-11:1 HD 6.9-10.4:1 | 212mm [8.35"] | 214mm [8.43"] |
| WITHOUT PROJECTION LENS | 277mm [10.92"] | 226mm [8.90"] |

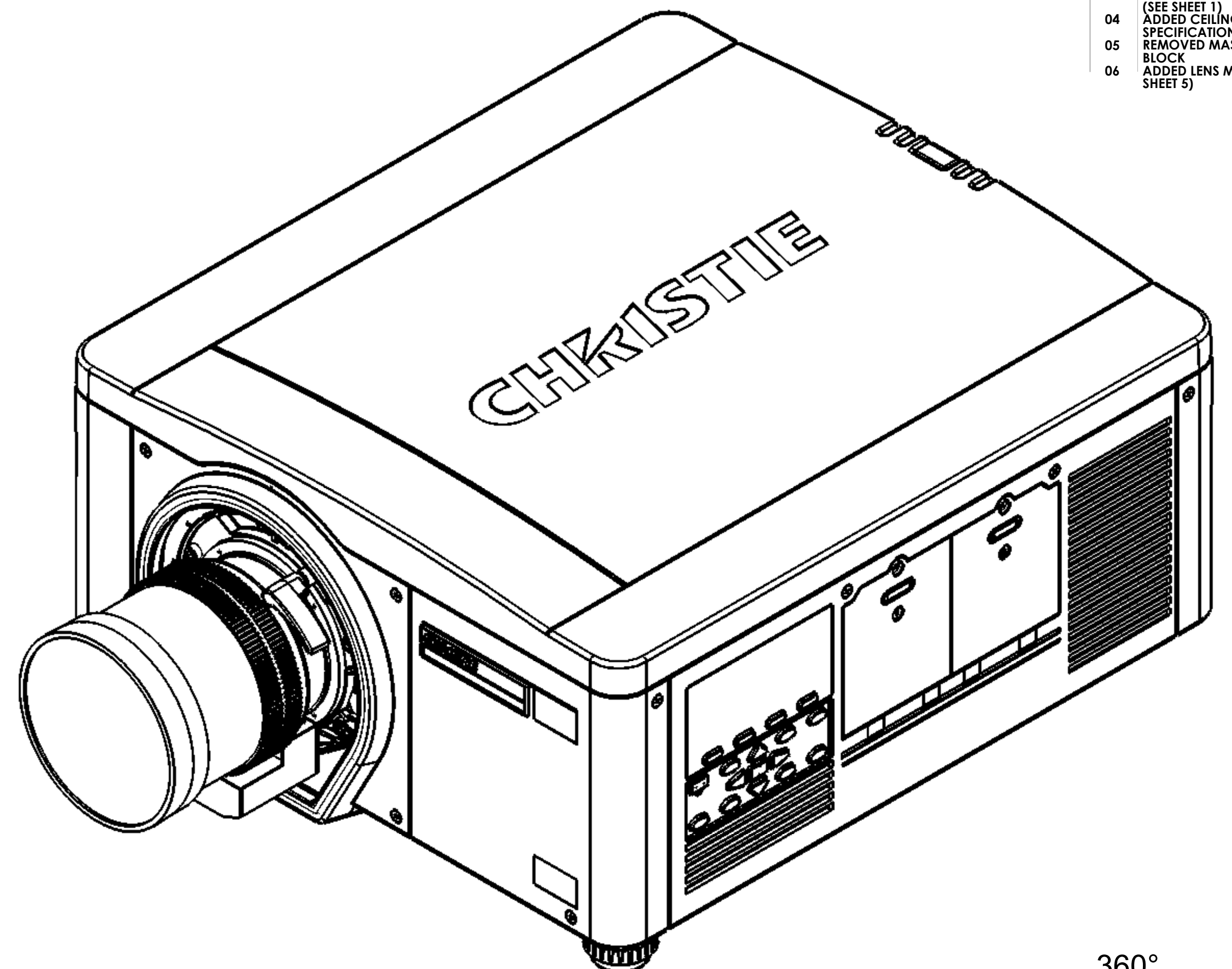

ISOMETRIC VIEW

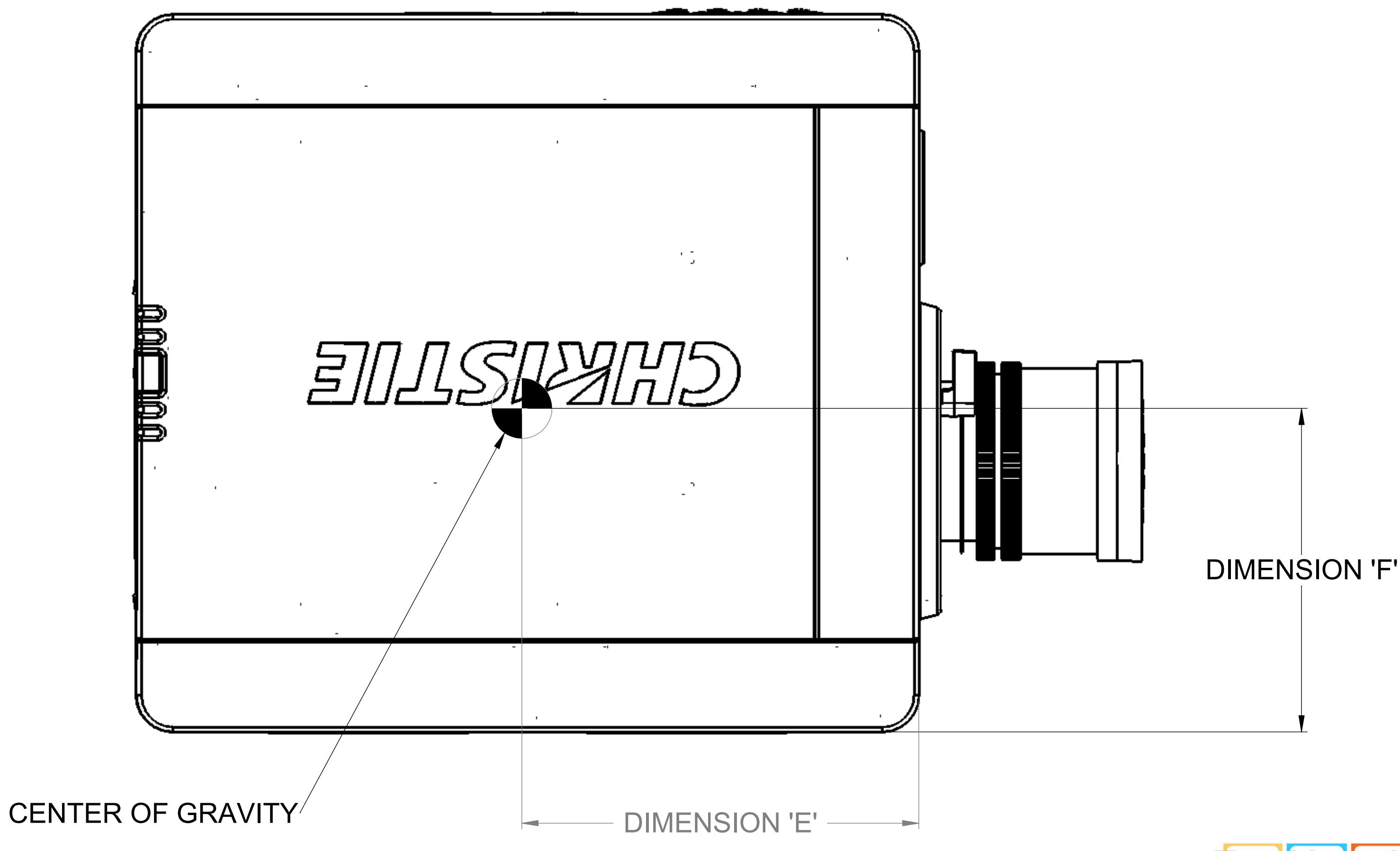
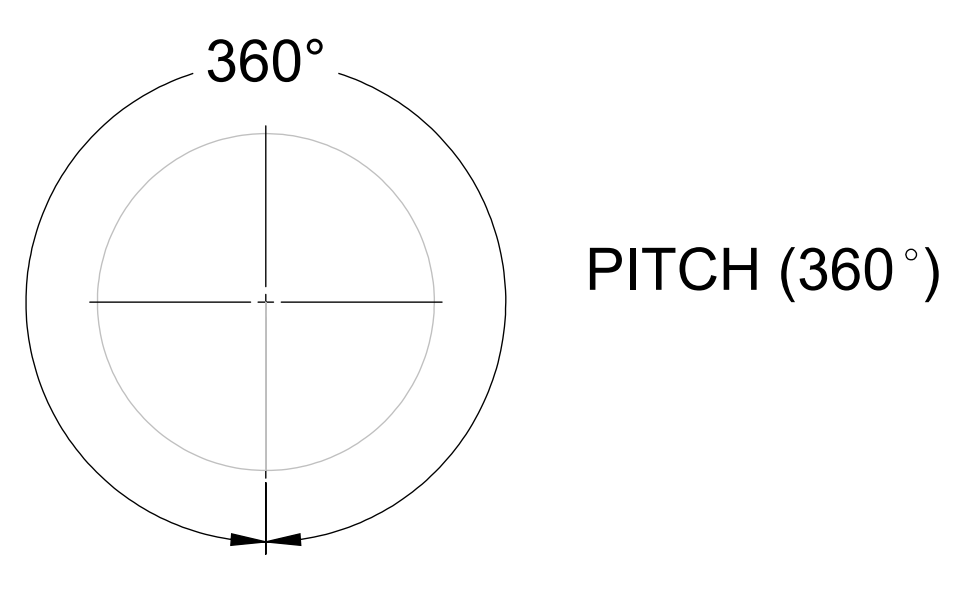

CENTER OF GRAVITY

DIMENSION 'F'

DIMENSION 'E'

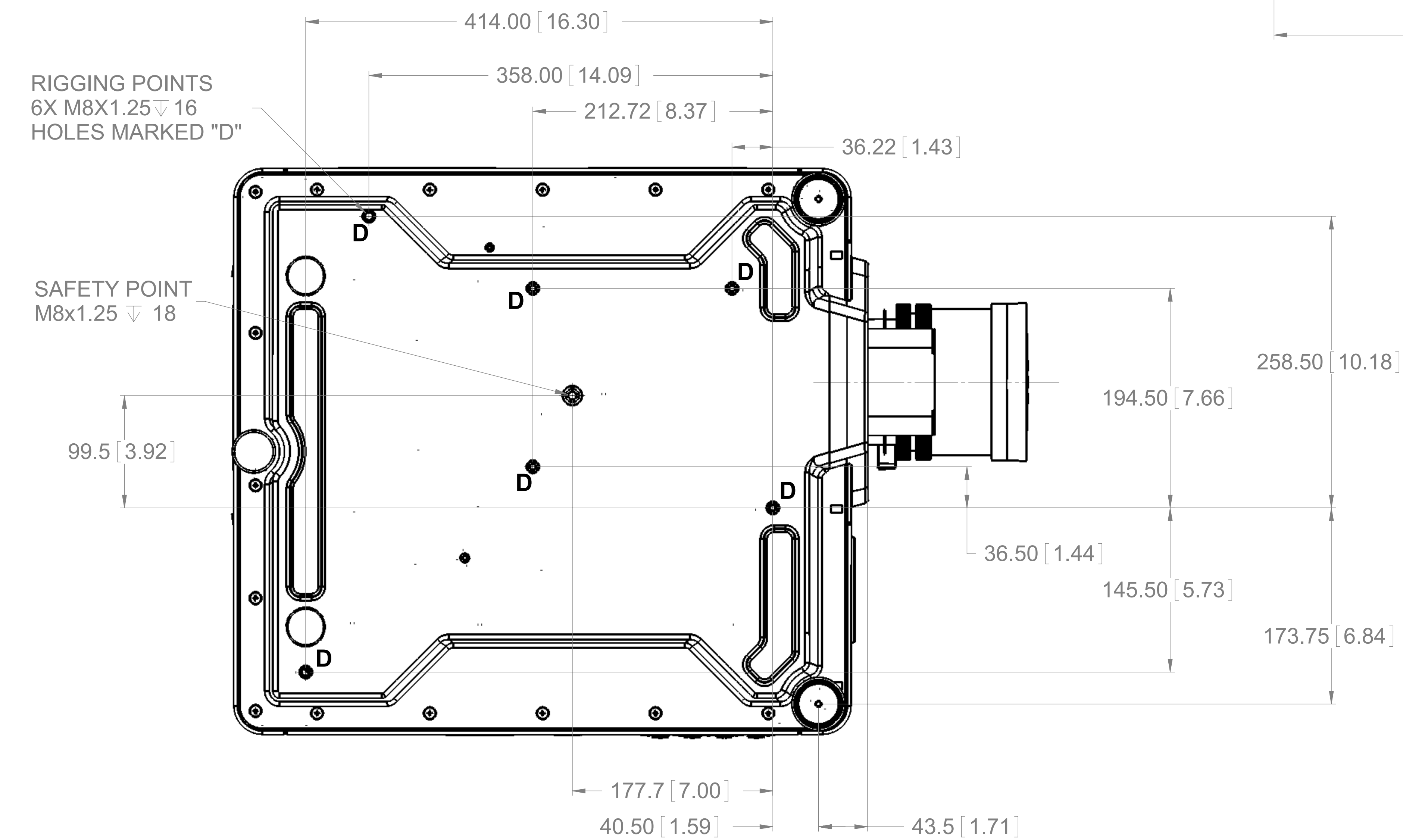
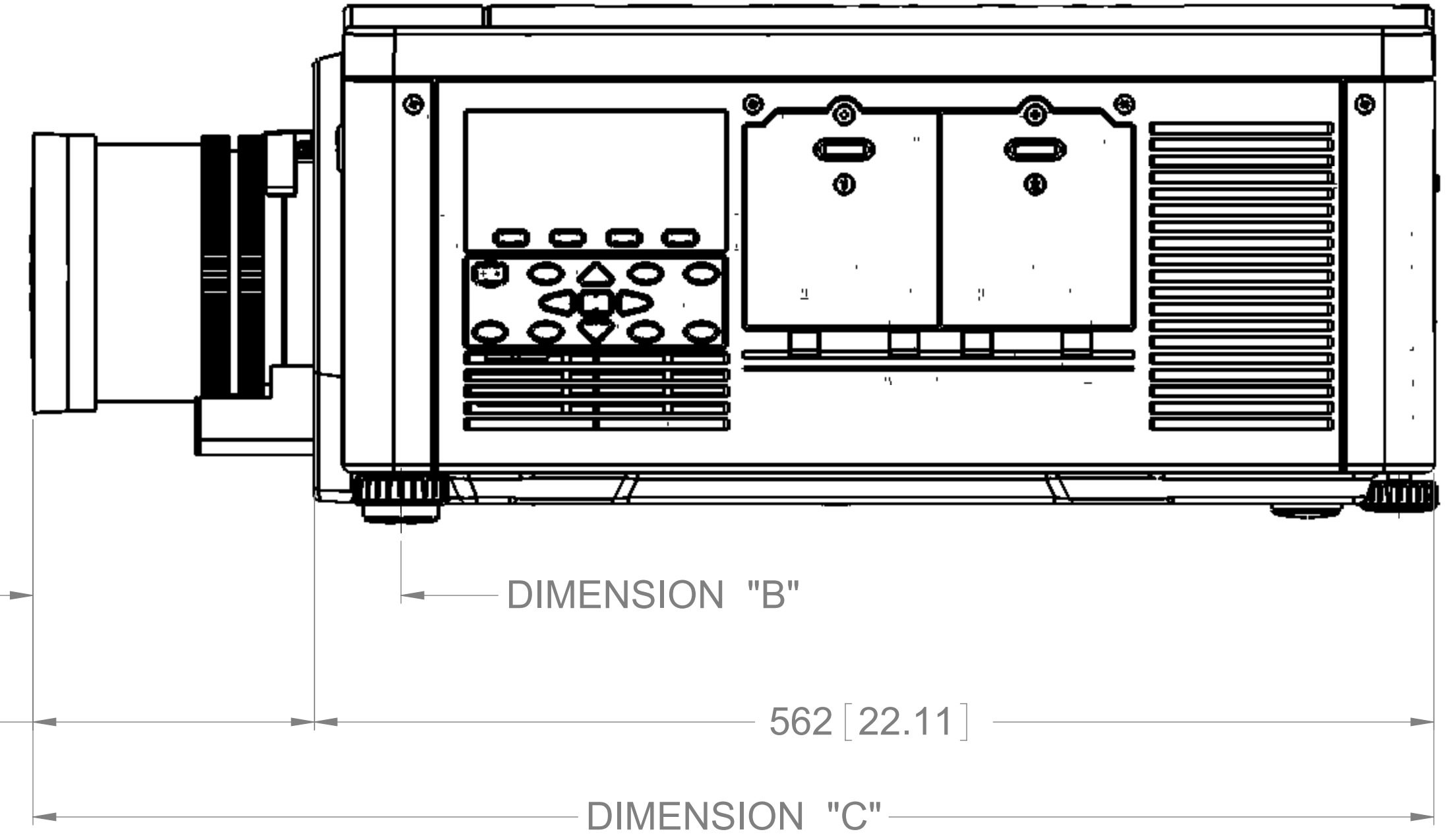
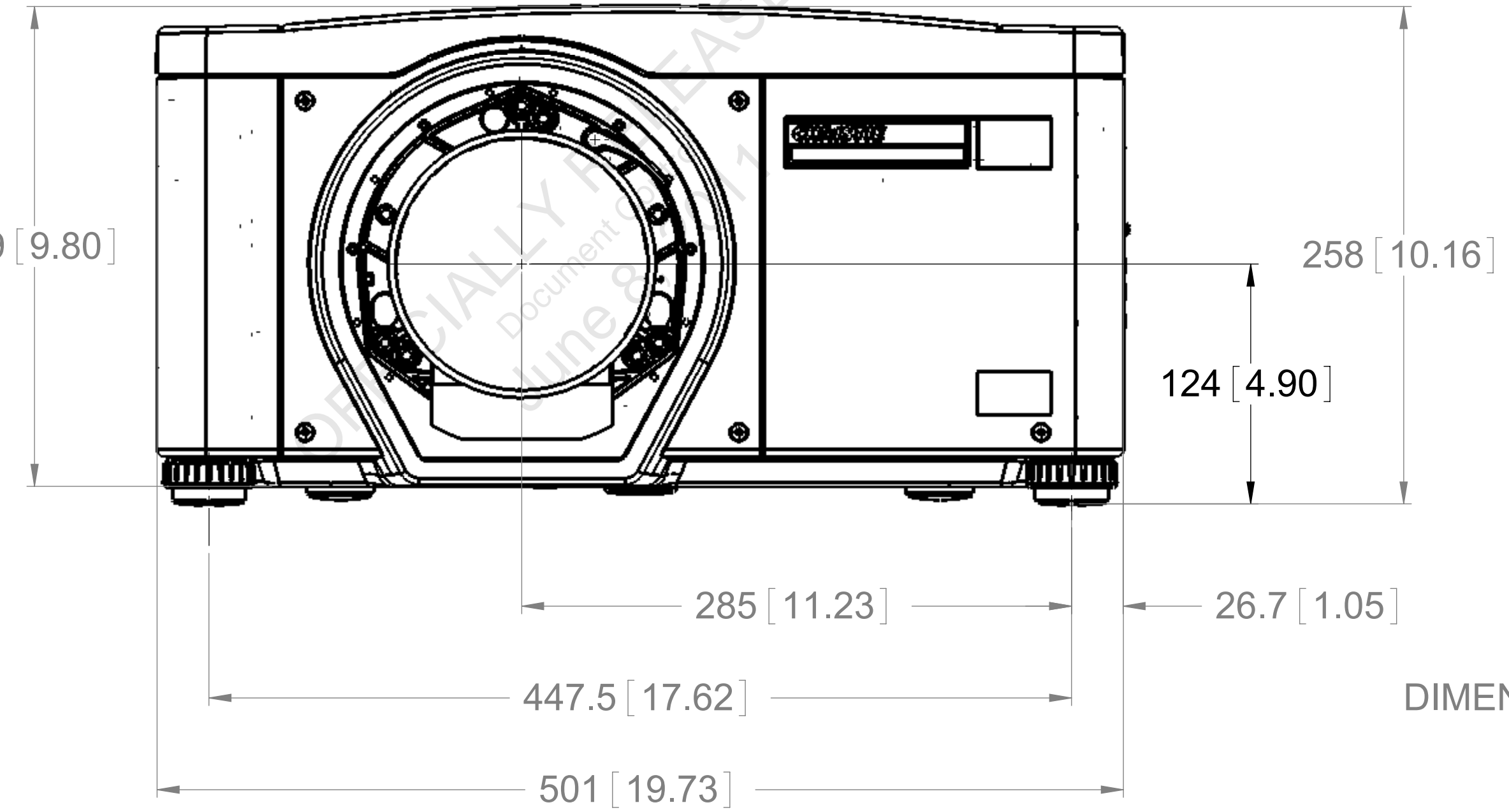
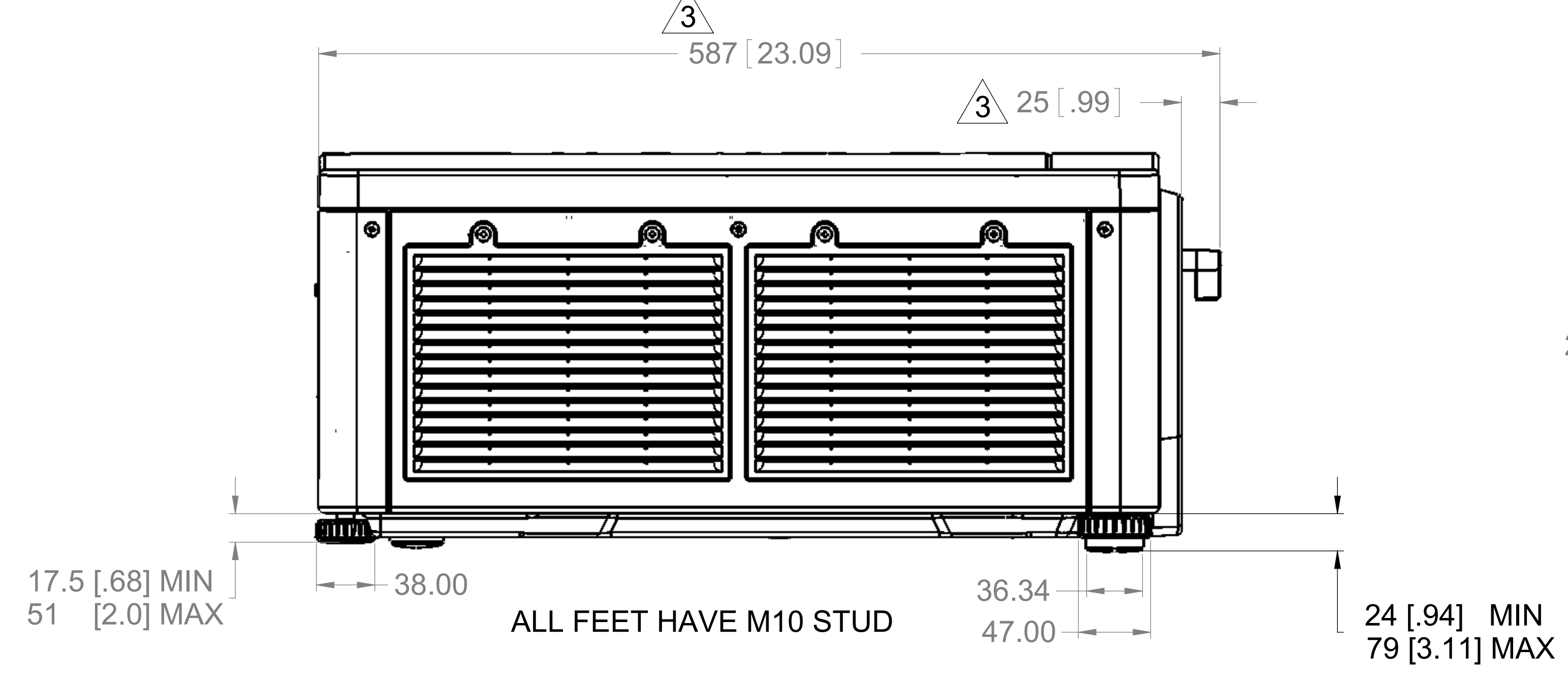
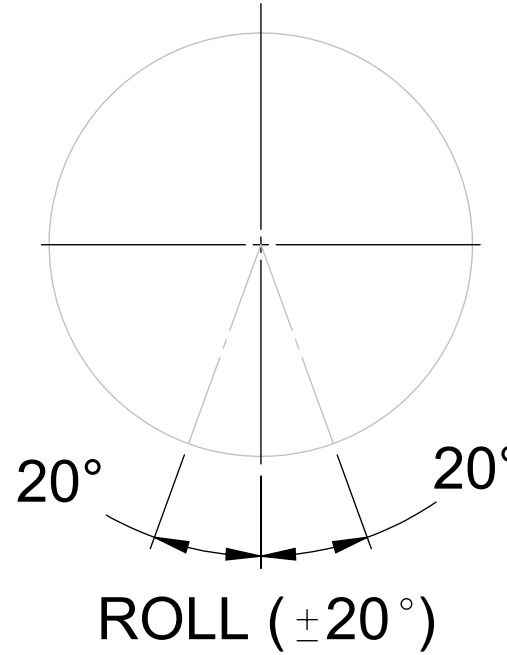

GENERAL NOTES:
 MASS: 25 kg (55 lbs) WITHOUT PROJECTION LENS
 AMBIENT AIR TEMPERATURE: 5°C (41°F) TO 40°C (104°F)

| LENS | DIMENSION 'A' | DIMENSION 'B' | DIMENSION 'C' |
|------------------------------------|----------------|-----------------|-----------------|
| SXGA+ 0.73:1 HD 0.67:1 | 217mm [8.54"] | 261mm [10.27"] | 779mm [30.66"] |
| SXGA+ 1.2:1 HD 1.1:1 | 281mm [11.06"] | 325mm [12.79"] | 843mm [33.18"] |
| SXGA+ 1.25-1.6:1 HD 1.16-1.49:1 | 238 mm [9.37"] | 282 mm [11.10"] | 800 mm [31.49"] |
| SXGA+ 1.5-2.0:1 HD 1.4-1.8:1 | 206mm [8.11"] | 250mm [9.84"] | 768mm [30.23"] |
| SXGA+ 2.0-2.8:1 HD 1.8-2.6:1 | 171mm [6.73"] | 215mm [8.46"] | 733mm [28.85"] |
| SXGA+ 2.8-4.5:1 HD 2.6-4.1:1 | 157mm [6.18"] | 201mm [7.91"] | 719mm [28.30"] |
| SXGA+ 4.5-7.5:1 HD 4.1-6.9:1 | 141mm [5.51"] | 185mm [7.28"] | 703mm [27.62"] |
| SXGA+ 7.5-11:1 HD 6.9-10.4:1 | 201mm [7.91"] | 245mm [9.64"] | 763mm [30.03"] |

UNITS: INCHES () MILLIMETRES ()
 UNLESS OTHERWISE SPECIFIED
 INTERFERE DIMENSIONS AND TOLERANCES PER ASME Y14.5M-1994
 TOLERANCES APPLY AS SHOWN BELOW

| DECIMAL PLACES | INCHES | MILLIMETRES |
|----------------|--------|-------------|
| XXX | ± 0.03 | ± 1.4 |
| XX | ± 0.15 | ± 3.1 |
| X | ± 0.50 | ± 8.3 |

ANGULAR DIMENSIONS: 10.0° ± 0.5° 50.0° ± 1.0°

THIRD ANGLE PROJECTION

CHRISTIE DIGITAL SYSTEMS USA, INC. CHRISTIE DIGITAL SYSTEMS CANADA, INC.

CHRISTIE

M-SERIES LINE DRAWING

SCALE: 1:2.5 MASS: - LBS (- KG)

SHEET 1 OF 5

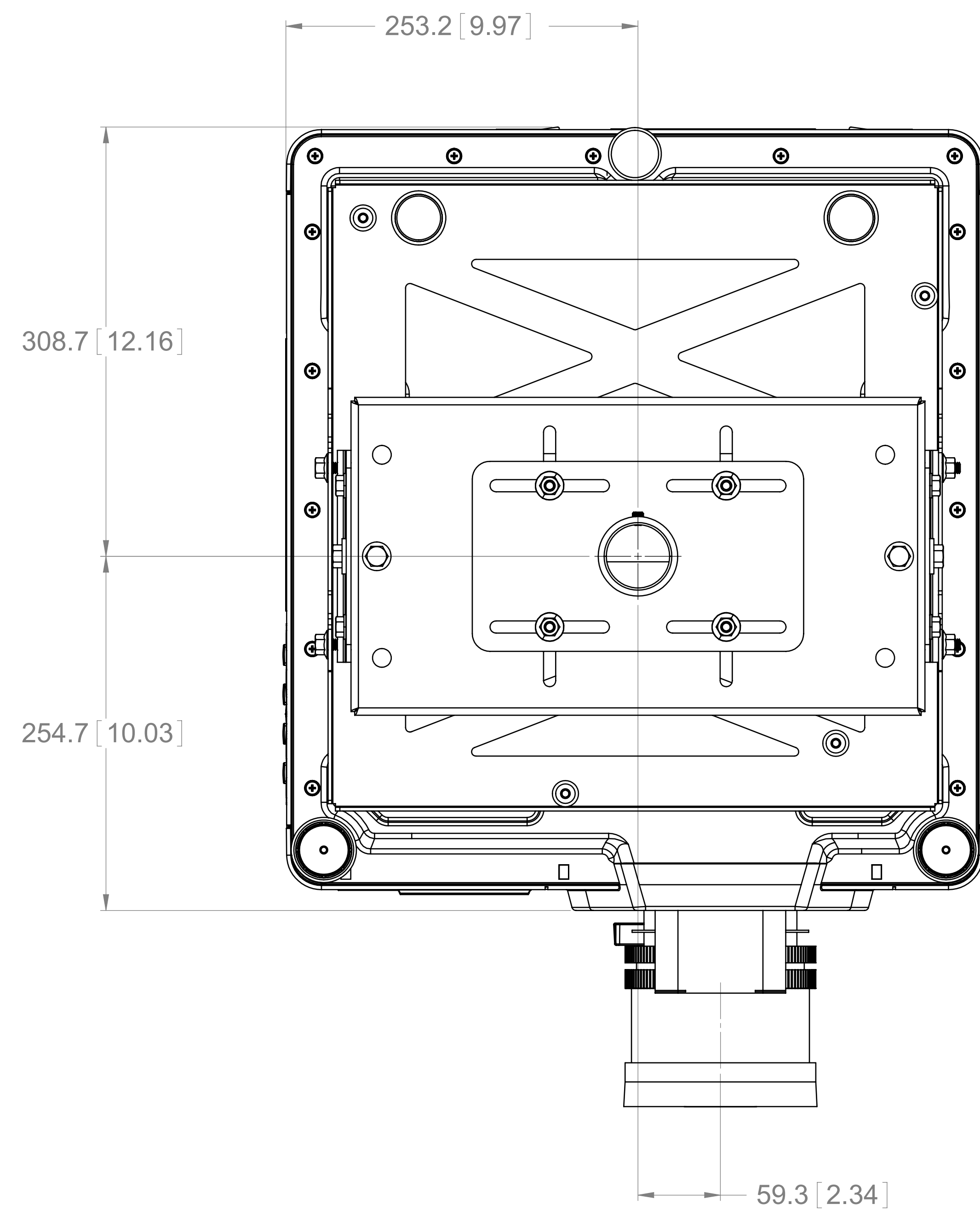

CEILING MOUNT M-SERIES 118-100108-01



| CEILING MOUNT SPECIFICATION | |
|-----------------------------|--------------------|
| ROLL | ± 5° |
| PITCH | ± 20° |
| YAW | 360° |
| COLOUR | BLACK |
| WEIGHT CAPACITY | 250 lbs (113.6 kg) |
| X AXIS MOTION RANGE | 77.2 mm (3.04") |
| Y AXIS MOTION RANGE | 77.2 mm (3.04") |

NOTE: 1/2" WRENCH REQUIRED FOR ADJUSTMENT OF AXES AND ANGLE POSITIONS

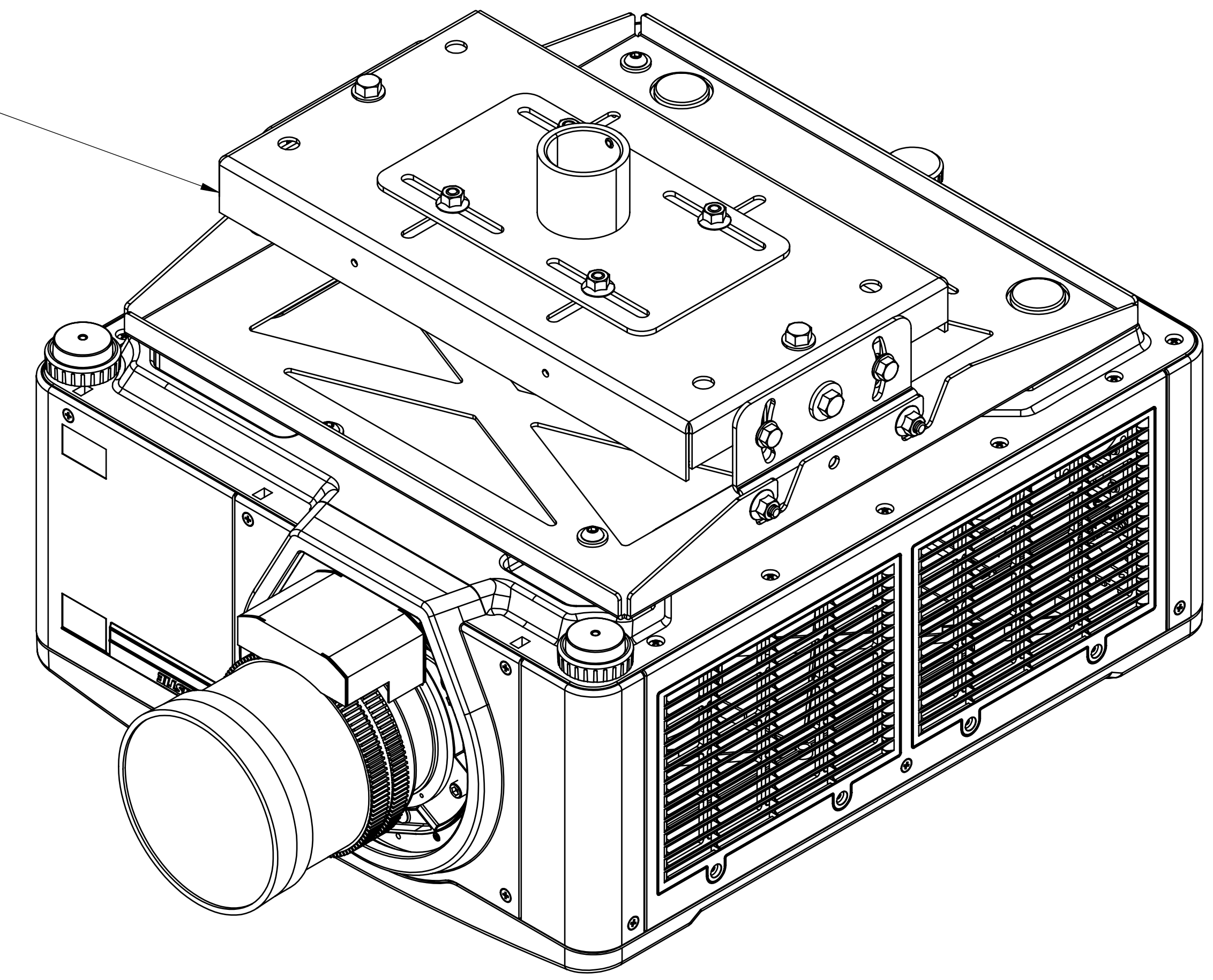

ISOMETRIC VIEW

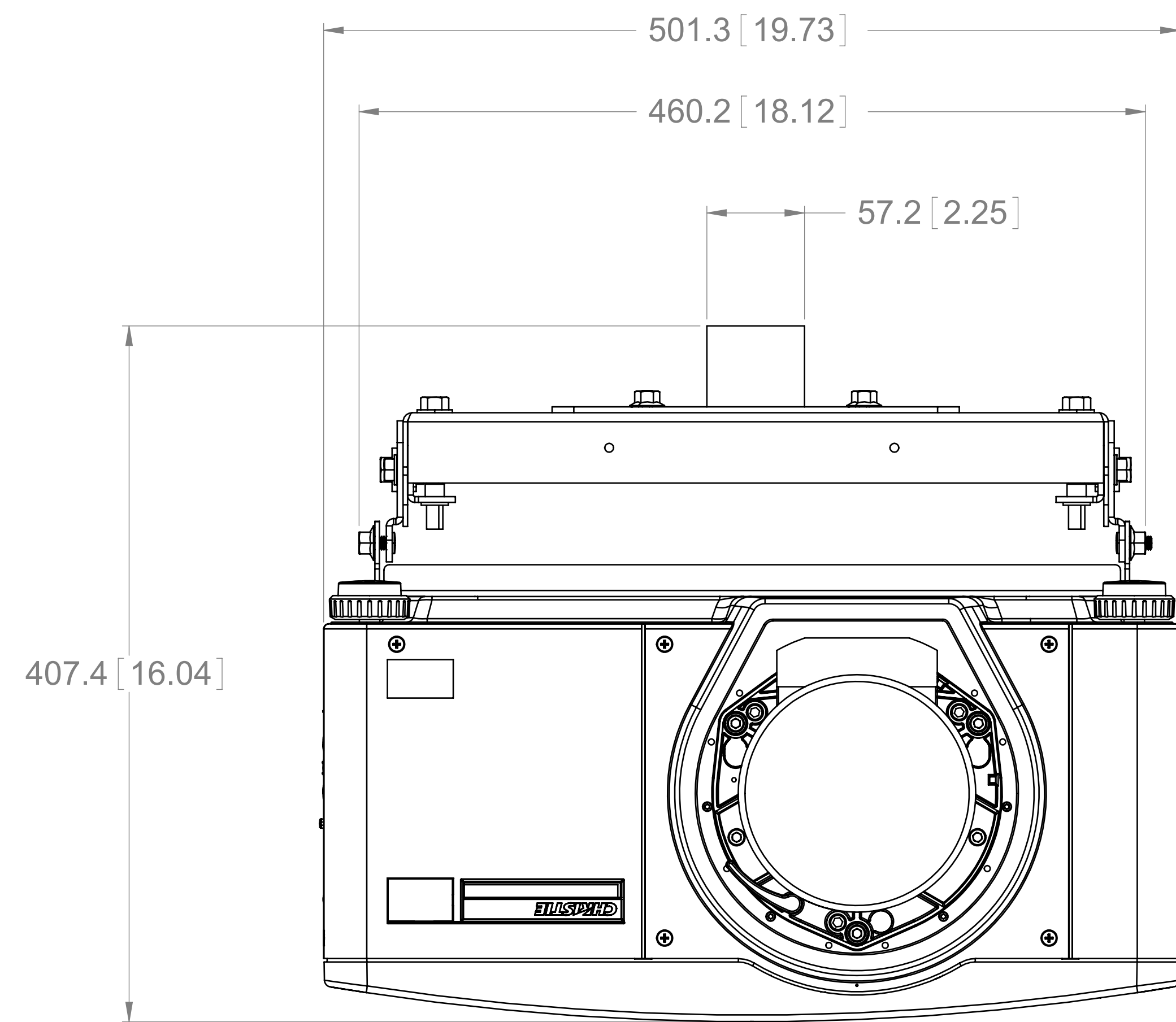

OFFICIALLY RELEASED
Document Control
June 8, 2011

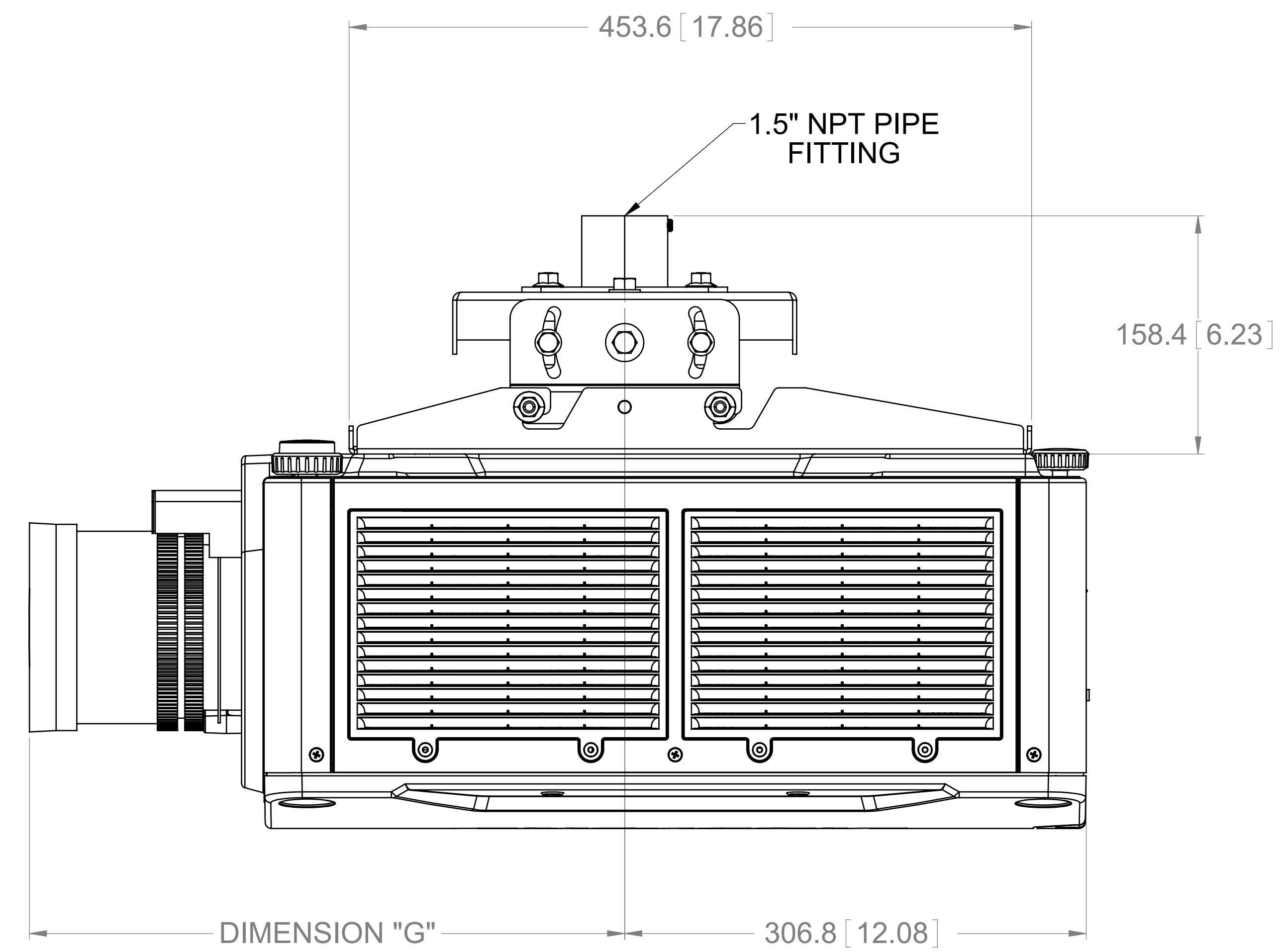

| LENS | DIMENSION "G" |
|------------------------------------|----------------|
| SXGA+ 0.73:1 HD 0.62:1 | 585mm [23.05"] |
| SXGA+ 1.2:1 HD 1.1:1 | 649mm [25.48"] |
| SXGA+ 1.25-1.6:1 HD 1.16-1.49:1 | 606mm [23.90"] |
| SXGA+ 1.5-2.0:1 HD 1.4-1.8:1 | 574mm [22.64"] |
| SXGA+ 2.0-2.8:1 HD 1.8-2.6:1 | 539mm [21.26"] |
| SXGA+ 2.8-4.5:1 HD 2.6-4.1:1 | 525mm [20.70"] |
| SXGA+ 4.5-7.5:1 HD 4.1-6.9:1 | 509mm [20.07"] |
| SXGA+ 7.5-11:1 HD 6.9-10.4:1 | 569mm [22.42"] |

STACKING FRAME M-SERIES
118-100107-01

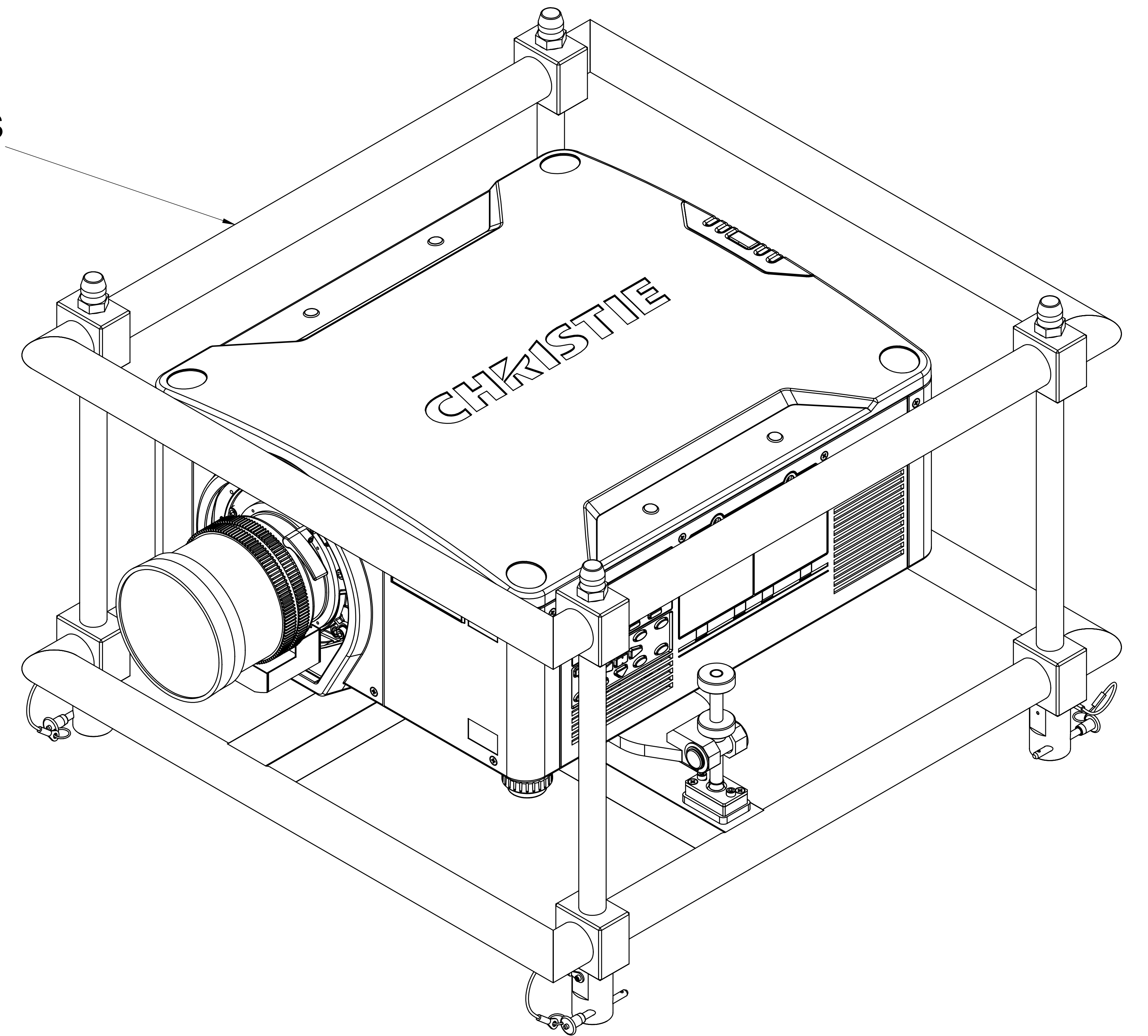
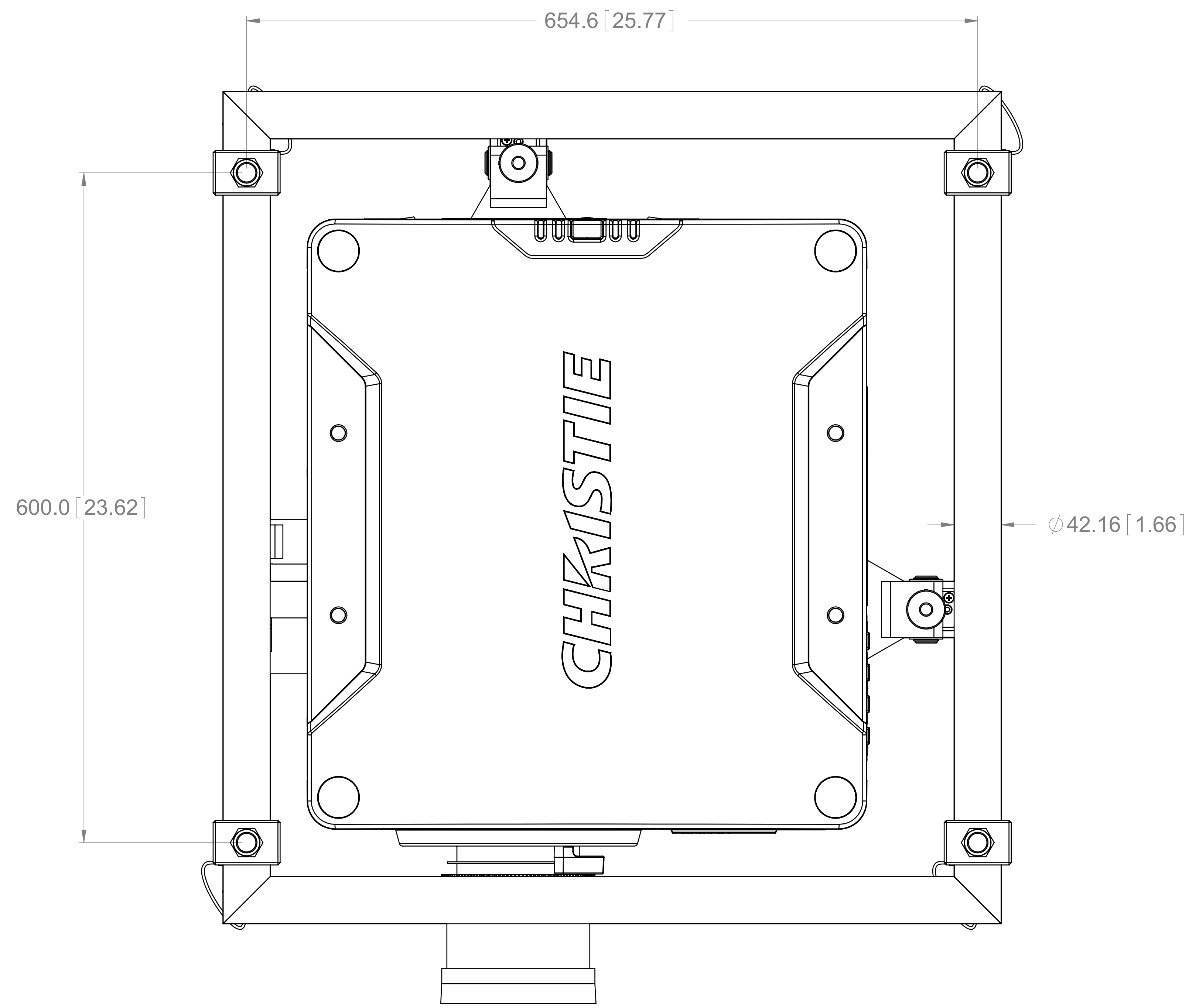

ISOMETRIC VIEW

OFFICIALLY RELEASED
Document Control
June 8, 2011

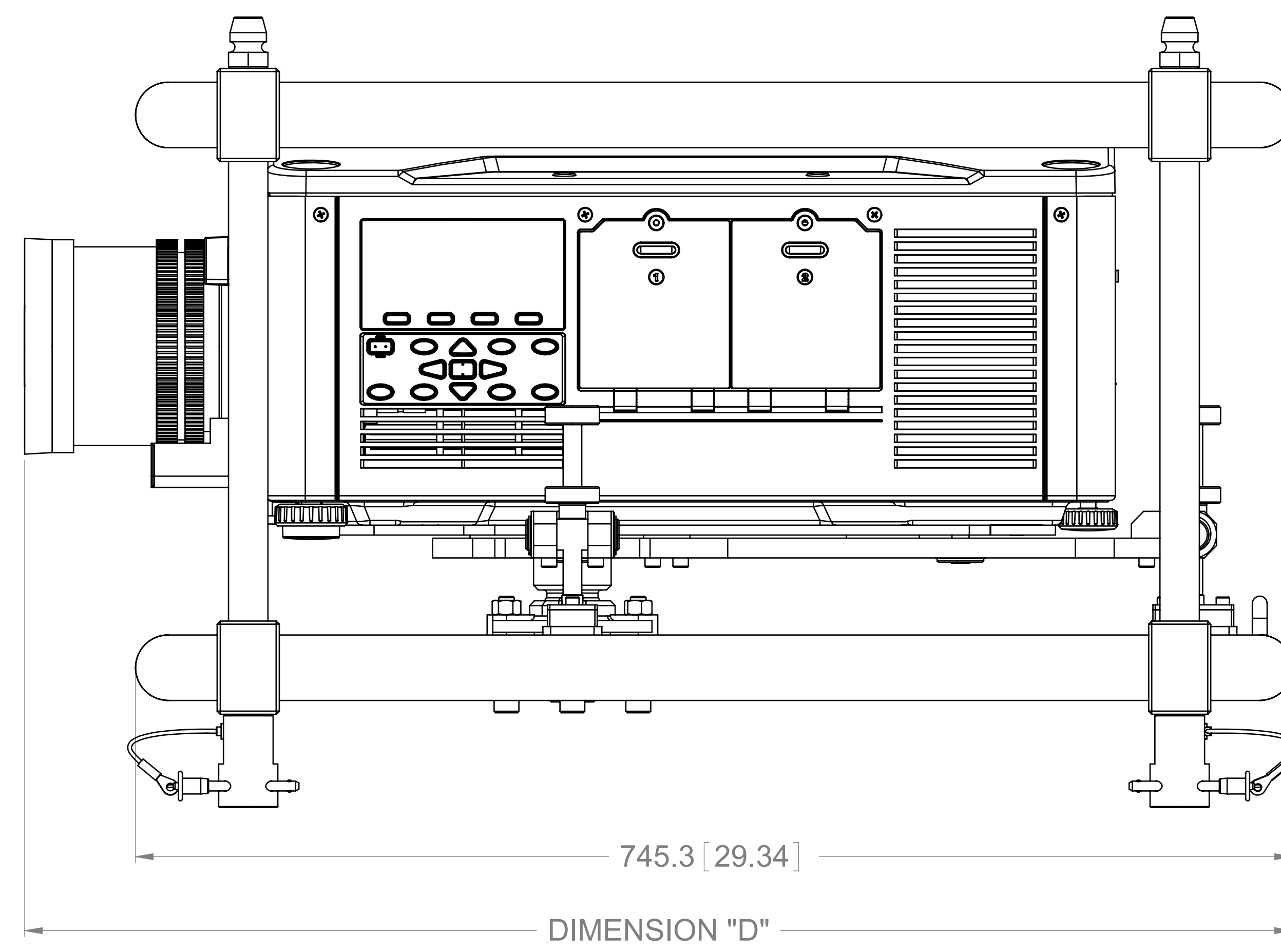
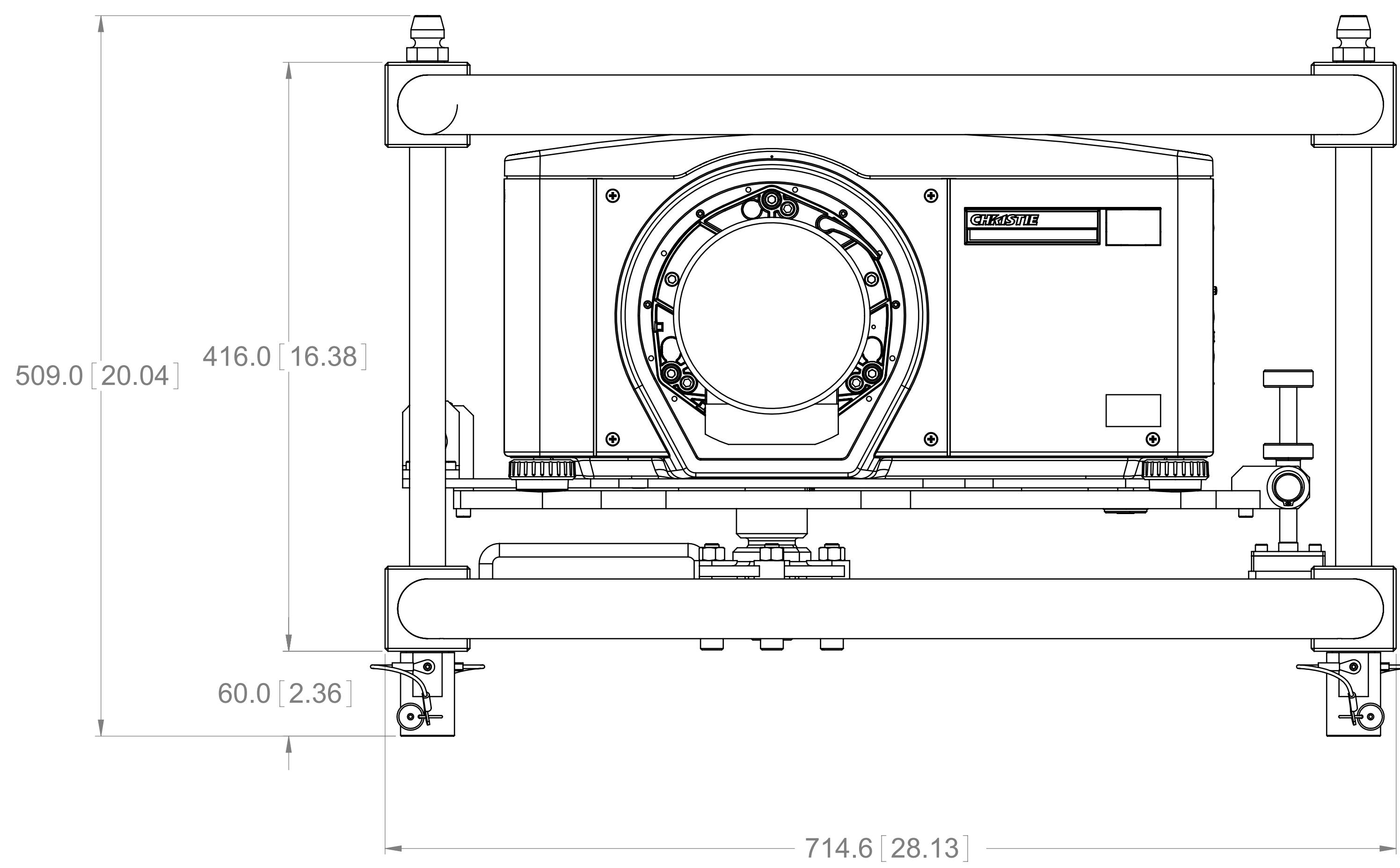

| LENS | DIMENSION "D" |
|------------------------------------|-----------------|
| SXGA+ 0.73:1 HD 0.67:1 | 892 mm [35.13"] |
| SXGA+ 1.2:1 HD 1.1:1 | 956 mm [37.56"] |
| SXGA+ 1.25-1.6:1 HD 1.16-1.49:1 | 913 mm [35.98"] |
| SXGA+ 1.5-2.0:1 HD 1.4-1.8:1 | 881 mm [34.72"] |
| SXGA+ 2.0-2.8:1 HD 1.8-2.6:1 | 846 mm [33.34"] |
| SXGA+ 2.8-4.5:1 HD 2.6-4.1:1 | 832 mm [32.78"] |
| SXGA+ 4.5-7.5:1 HD 4.1-6.9:1 | 816 mm [32.15"] |
| SXGA+ 7.5-11:1 HD 6.9-10.4:1 | 876 mm [34.50"] |

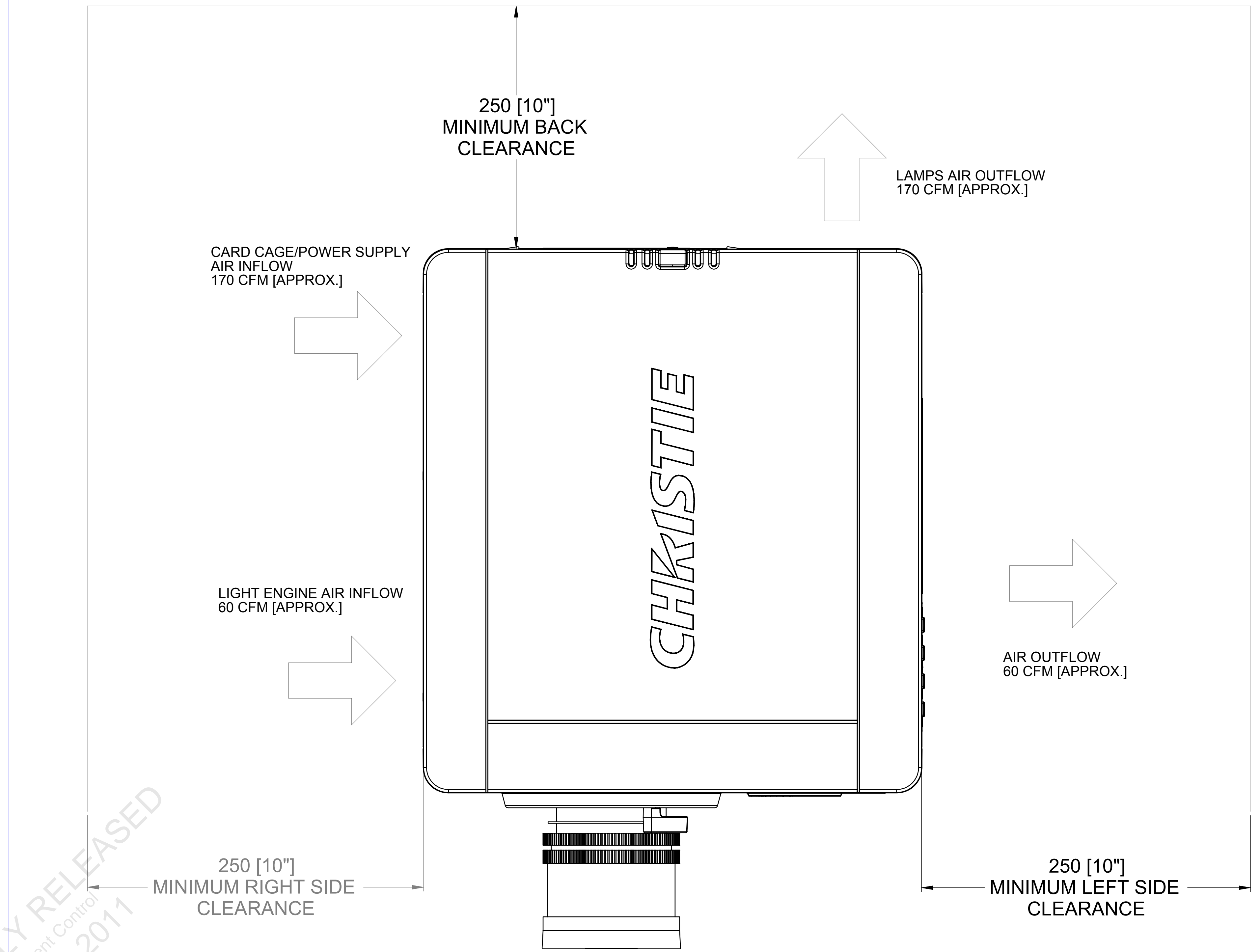
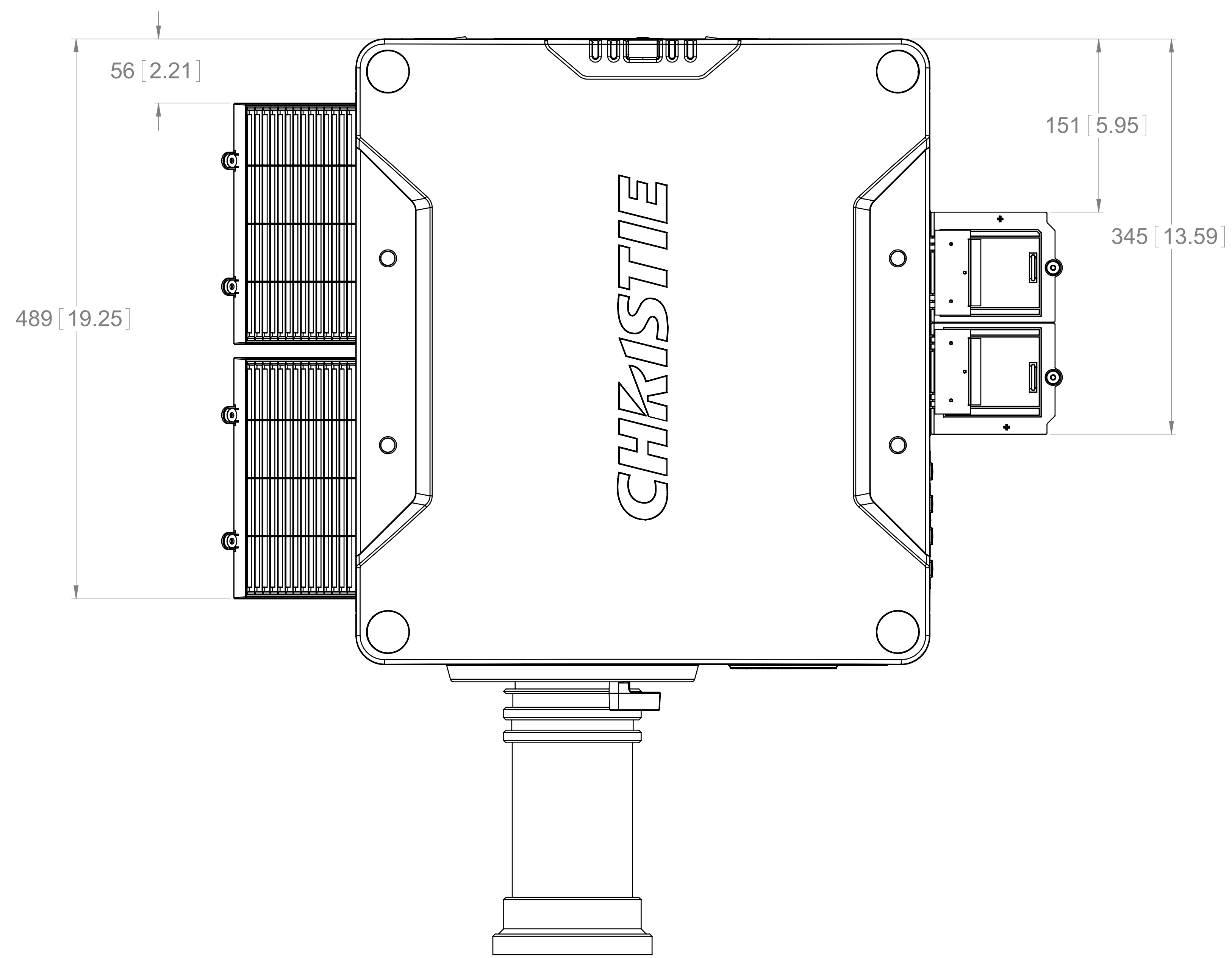

OFFICIALLY RELEASED
 Document Control
 June 8, 2011

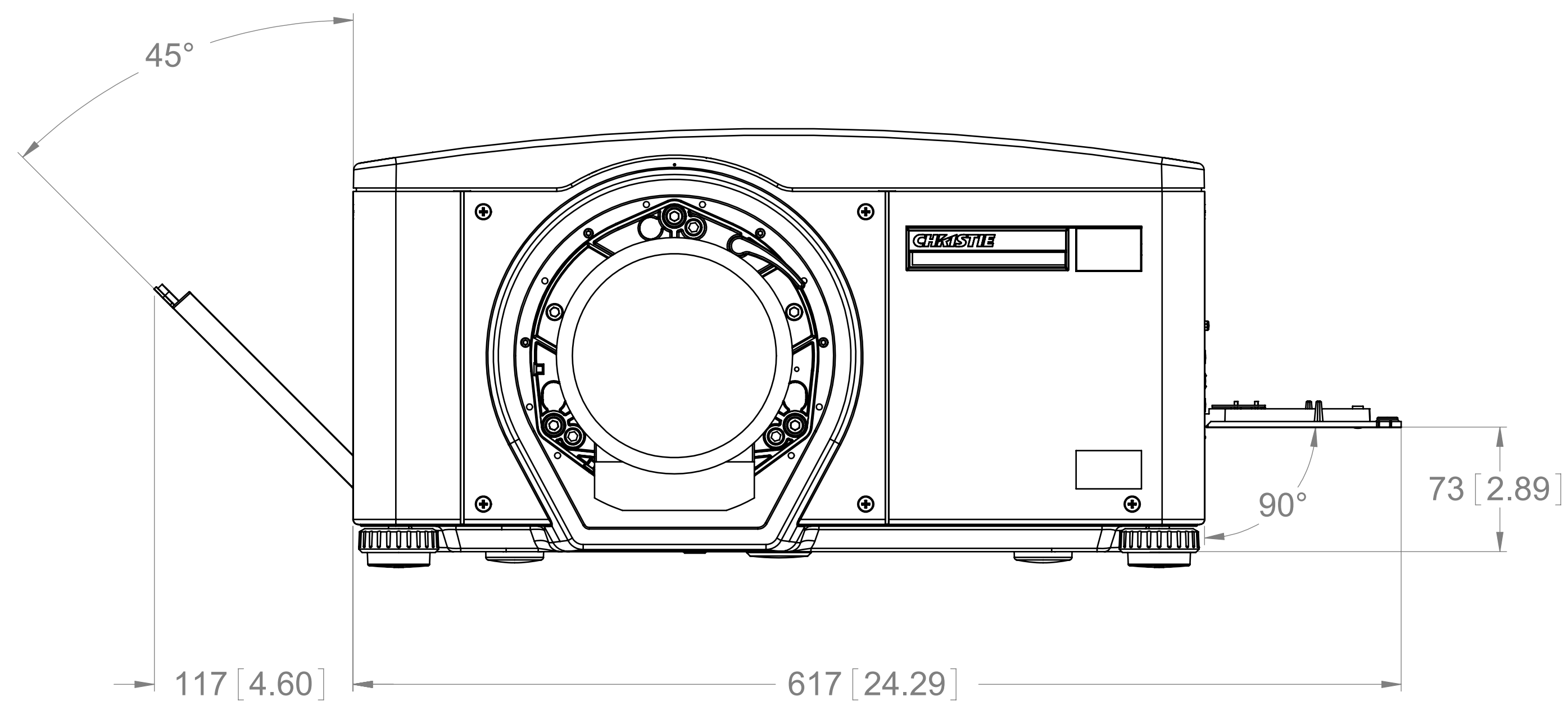

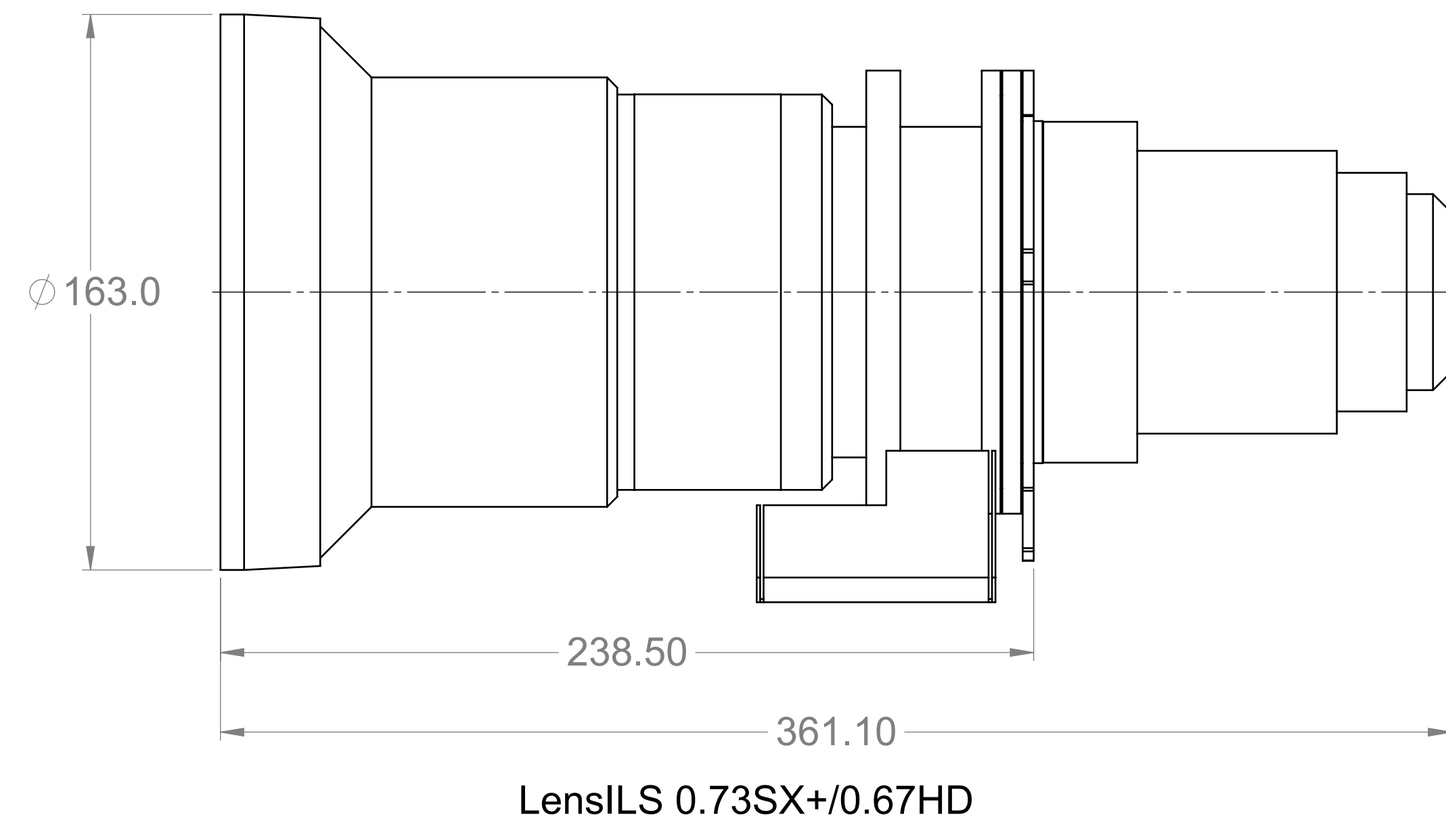

Lens ILS 0.73SX+/0.67HD

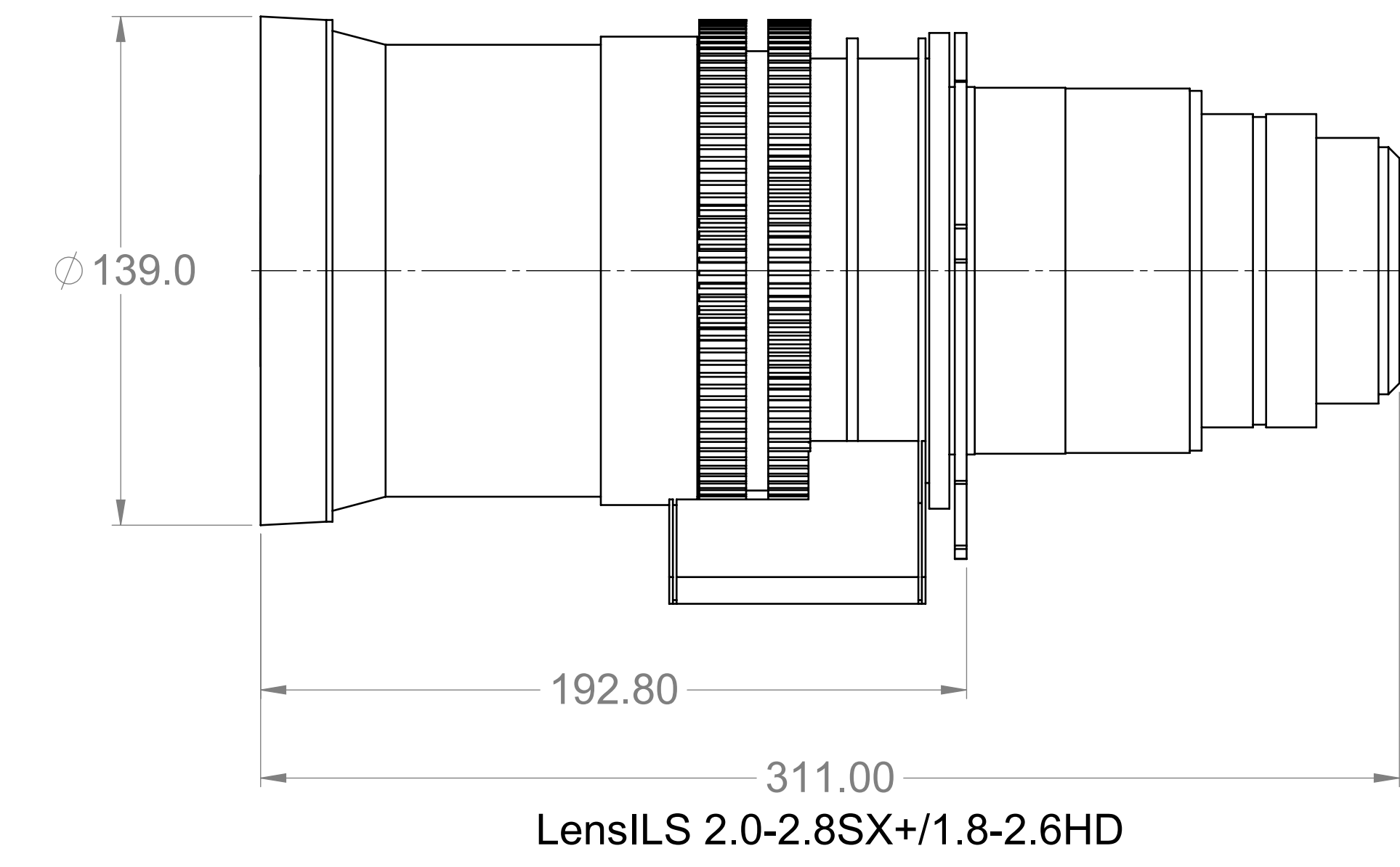

Lens ILS 2.0-2.8SX+/1.8-2.6HD

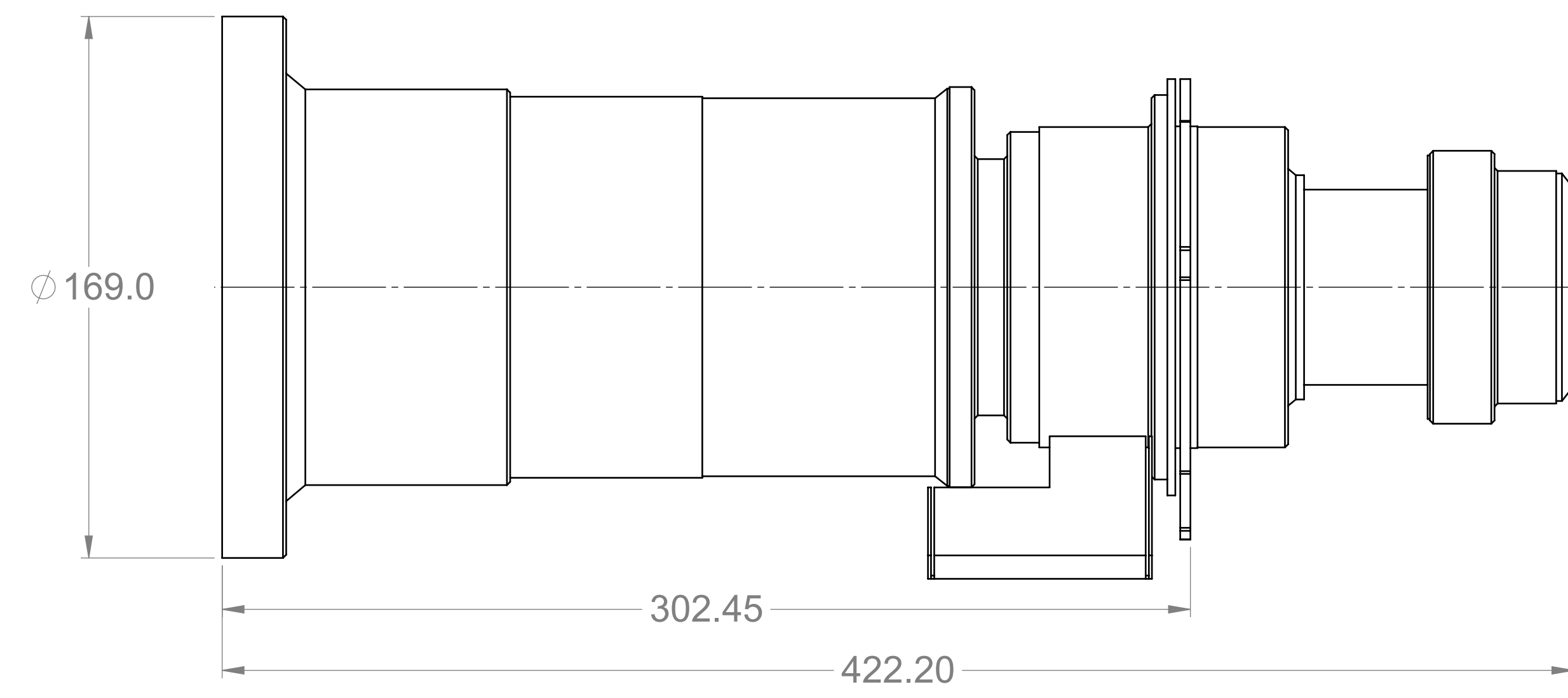

Lens ILS 1.2SX+/1.1HD

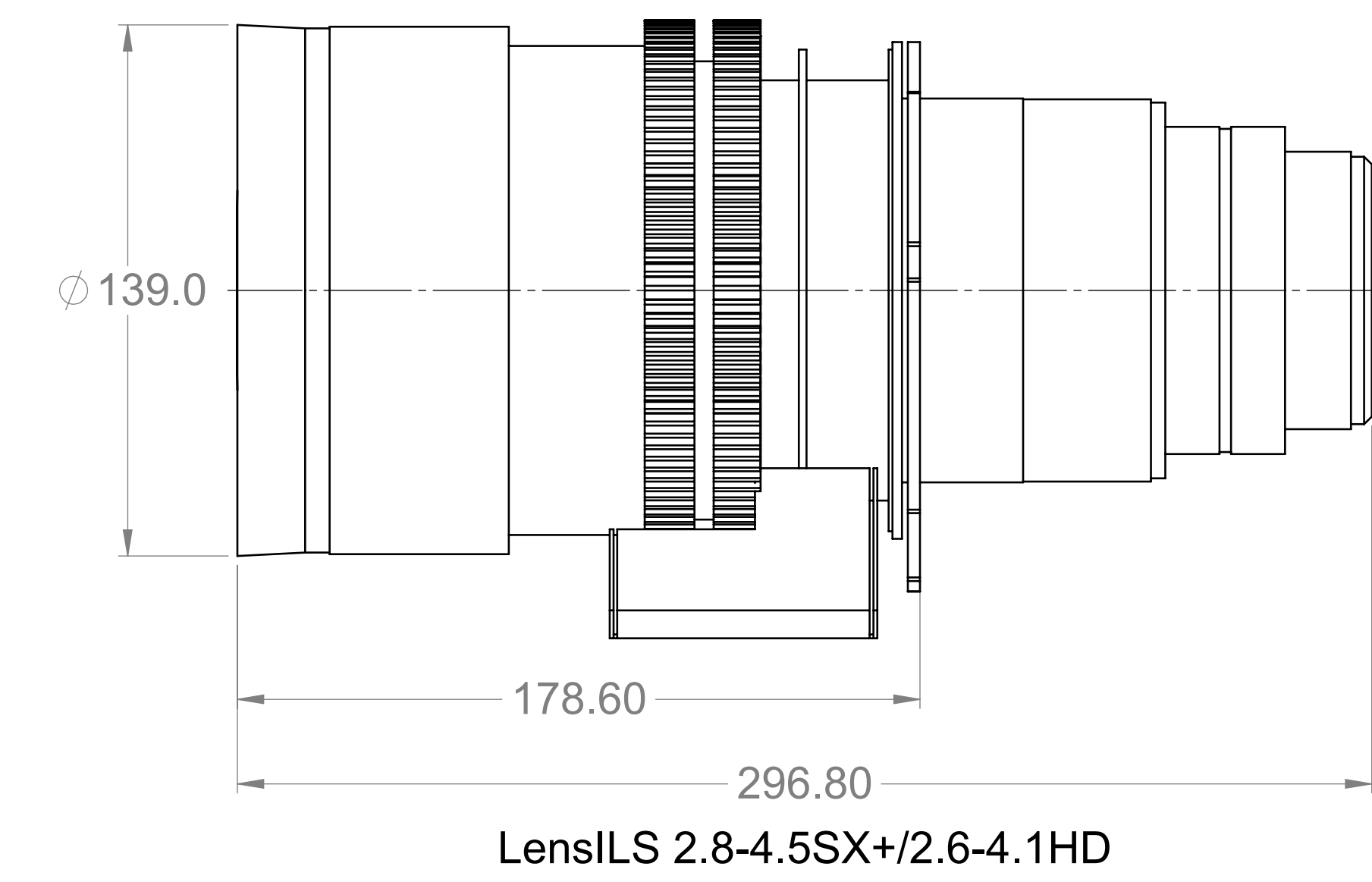

Lens ILS 2.8-4.5SX+/2.6-4.1HD

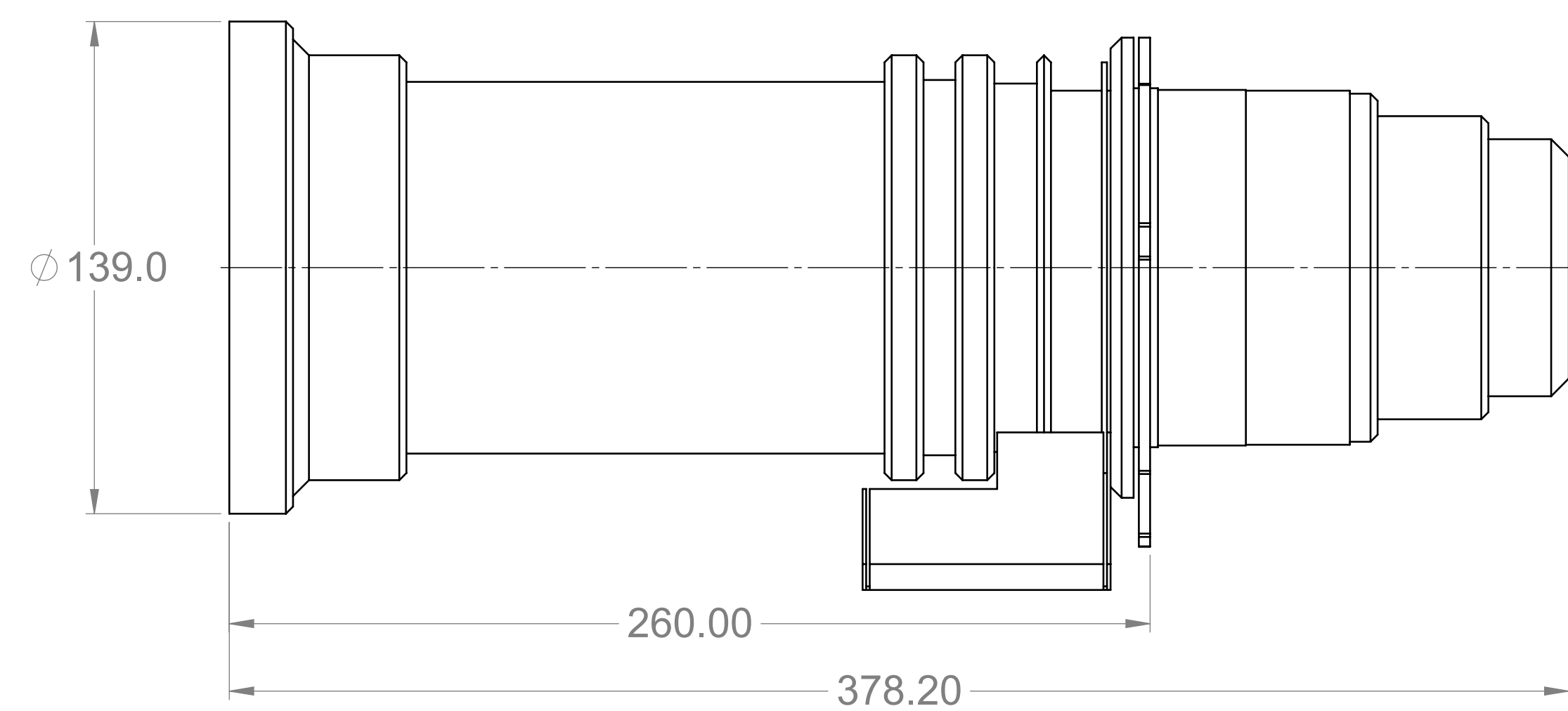

Lens ILS 1.25-1.6SX+/1.16-1.49HD

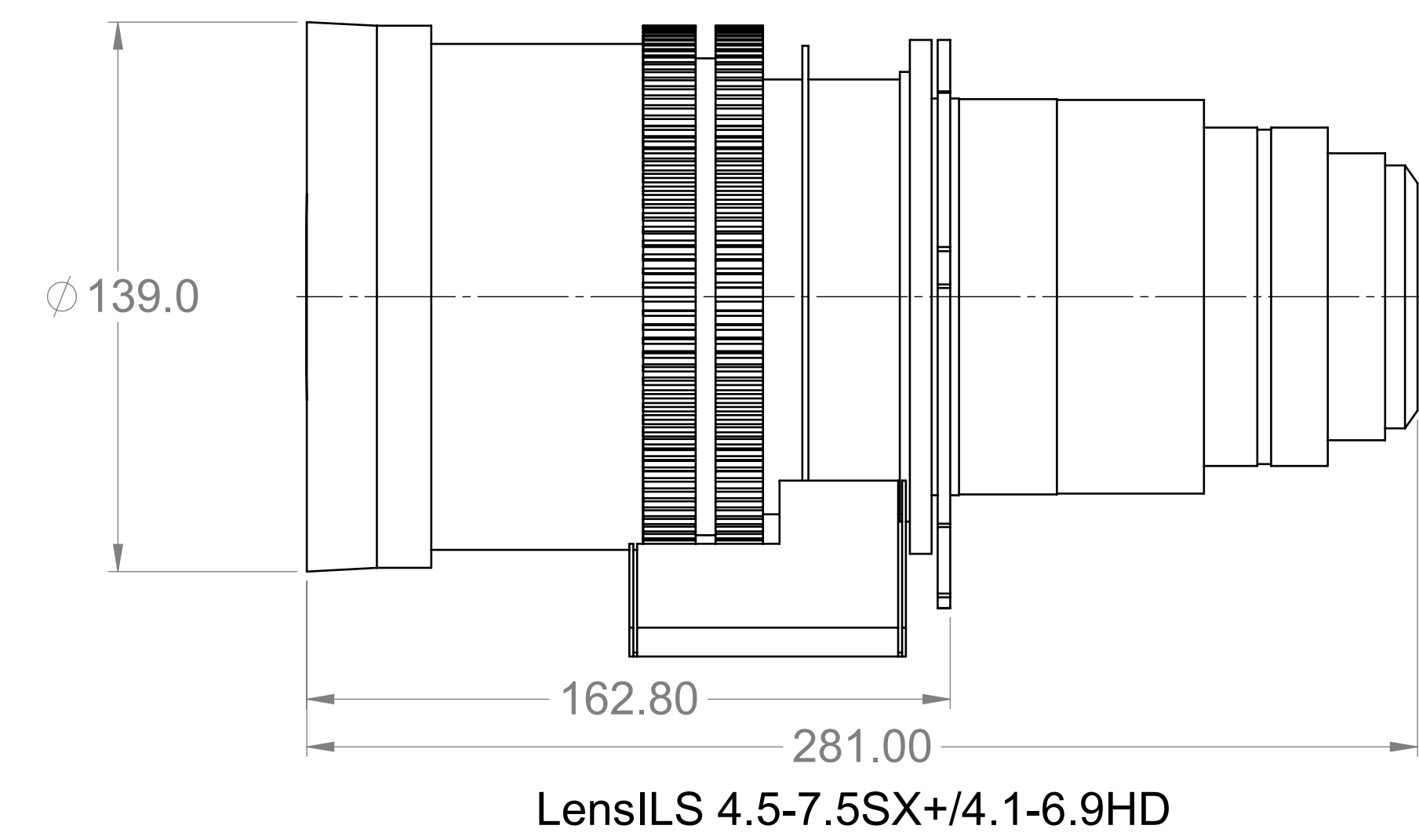

Lens ILS 4.5-7.5SX+/4.1-6.9HD

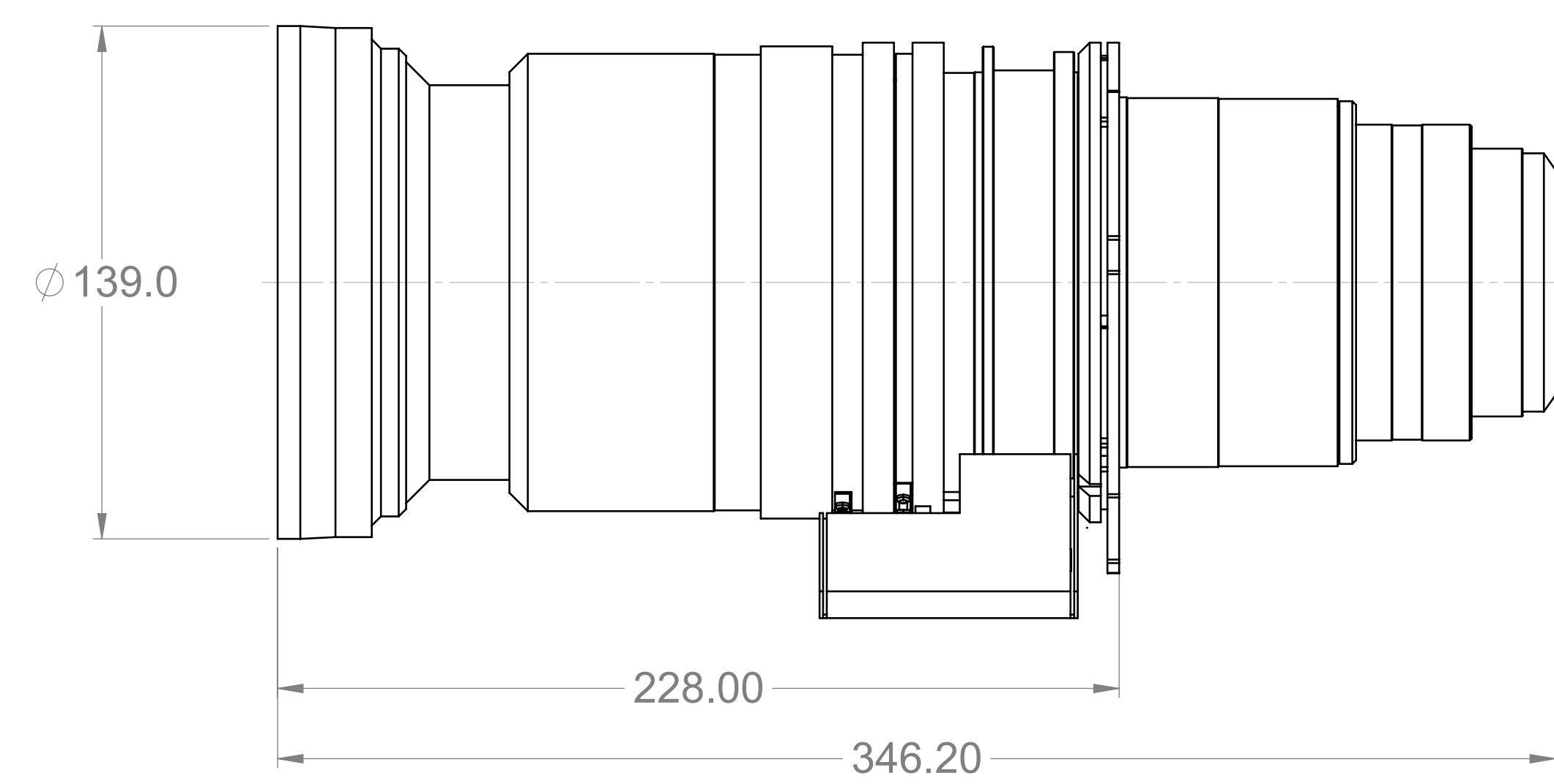

Lens ILS 1.5-2.0SX+/1.4-1.8HD

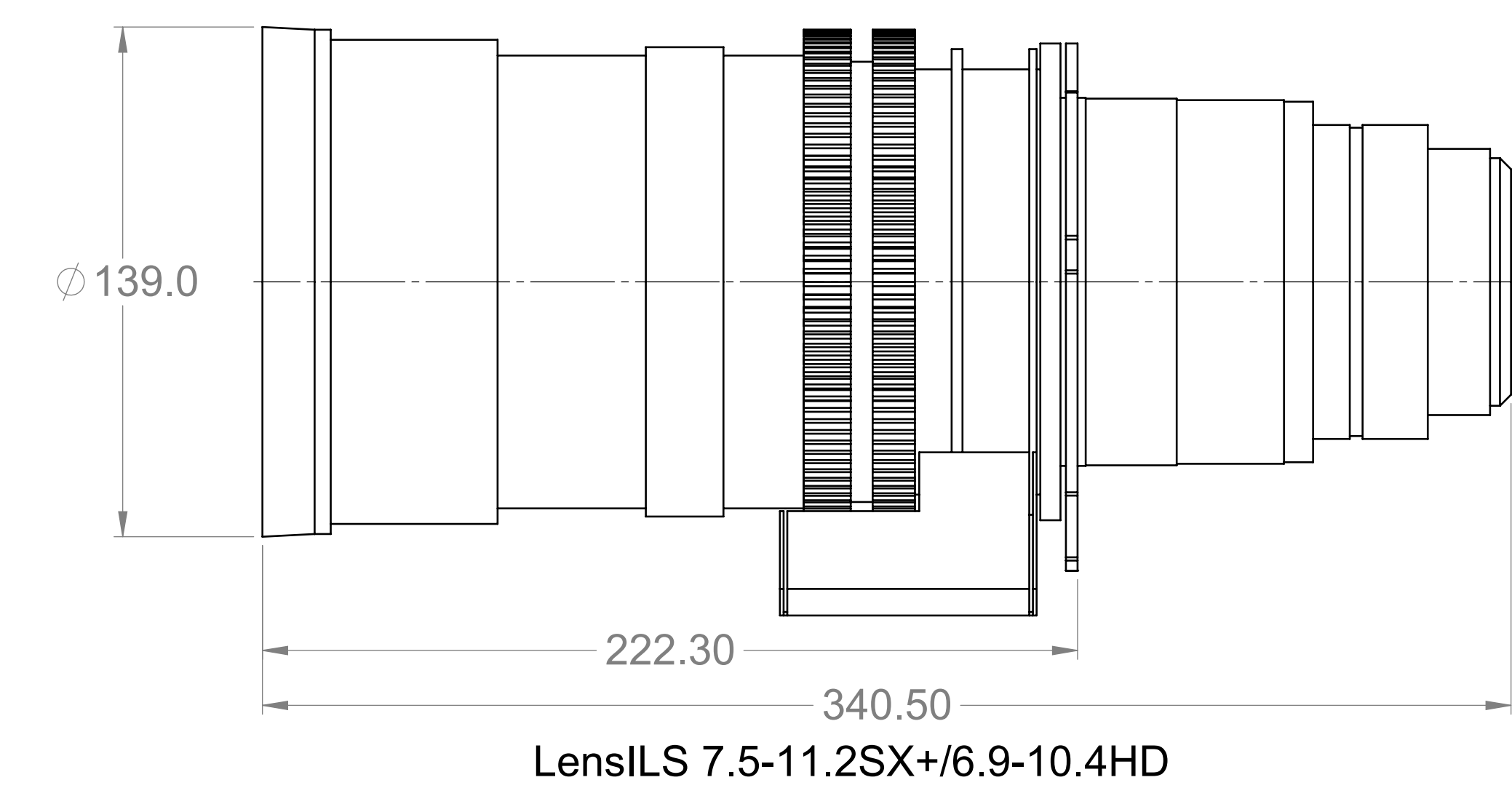

Lens ILS 7.5-11.2SX+/6.9-10.4HD

| LENS | MASS |
|------------------------------------|-------------------|
| SXGA+ 0.73:1 HD 0.67:1 | 12.34 LBS[5.60Kg] |
| SXGA+ 1.2:1 HD 1.1:1 | 13.65 LBS[6.19Kg] |
| SXGA+ 1.25-1.6:1 HD 1.16-1.49:1 | 13.91 LBS[6.31Kg] |
| SXGA+ 1.5-2.0:1 HD 1.4-1.8:1 | 13.25 LBS[6.01Kg] |
| SXGA+ 2.0-2.8:1 HD 1.8-2.6:1 | 10.96 LBS[4.97Kg] |
| SXGA+ 2.8-4.5:1 HD 2.6-4.1:1 | 11.40 LBS[5.17Kg] |
| SXGA+ 4.5-7.5:1 HD 4.1-6.9:1 | 8.33 LBS[3.78Kg] |
| SXGA+ 7.5-11:1 HD 6.9-10.4:1 | 11.23 LBS[5.09Kg] |

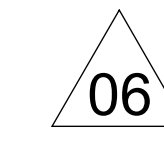

PROPRIETARY
NOT TO BE DISCLOSED OR REPRODUCED IN
ANY MANNER WITHOUT THE EXPRESS
WRITTEN PERMISSION OF
CHRISTIE

CHRISTIE
CHRISTIE DIGITAL SYSTEMS USA, INC.
CHRISTIE DIGITAL SYSTEMS CANADA, INC.

SIZE PART NUMBER
E

020-100192-01
SCALE 1:1.5 MASS - LBS (- KG) SHEET 5 OF 5

06