

# M Series Stacking Frame Flange Bearing 30mm Replacement Instruction Sheet

---

**⚠ WARNING** SAFETY CRITICAL ASSEMBLY! These work instructions must only be performed by an accredited service technician.

## INTRODUCTION

This procedure applies to all M Series Models. The flange bearing may wear out after extended use over a long period of time and will need to be replaced. The instructions explain how to remove and replace the flange bearing.

## KITS REQUIRED

ASSSY Flange Bearing 30mm (P/N# 003-003954-01)

## TOOLS REQUIRED

Allen Keys: 10mm, 8mm, and 4mm

Torque Wrench with 10mm, 8mm, and 4mm Allen heads

242 Loctite®

## INSTRUCTIONS

1. Remove (4) M10 cap screws.

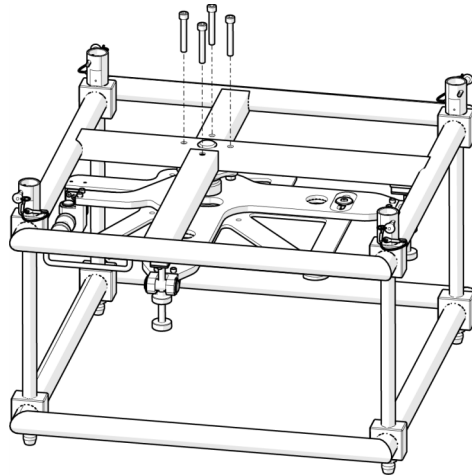

**Figure 1 M10 Cap Screws**

2. Remove (4) M5 cap screws.

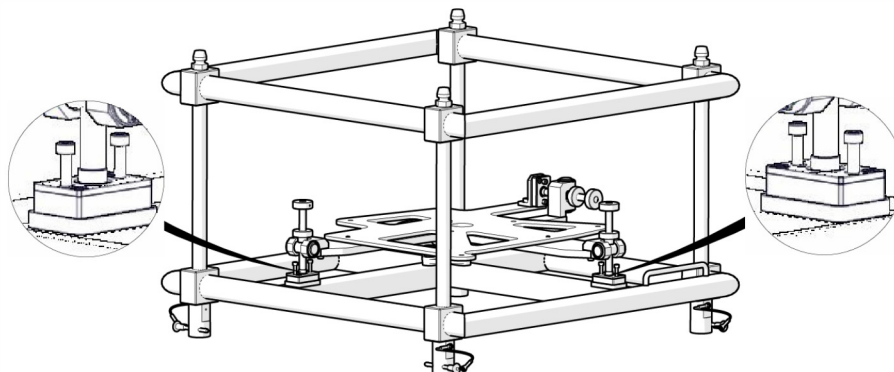
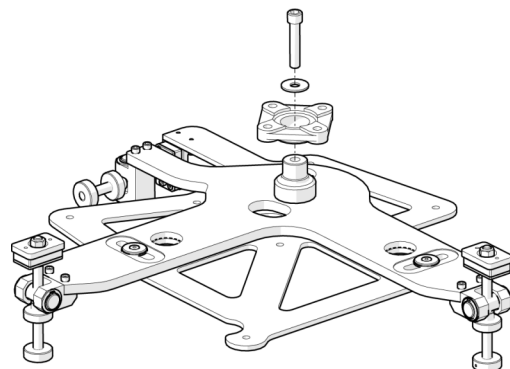

**Figure 2 M5 Cap Screws**

3. Remove M12 cap screw and washer.
4. Replace flange bearing and reassemble.

**NOTE:** 1) Torque M12 screw to 30Nm and apply Loctite 242 to threads. 2) Torque M5 screws to 3Nm and apply Loctite 242 to threads. 3) Torque M10 screws to 6Nm and apply Loctite 242 to threads.

**WARNING!** Make sure all screws and bolts are fastened properly. Failure to do so may result in serious injury or death.



**Figure 3 M12 Cap Screw and**