

Actuator Removal Instruction Sheet

INTRODUCTION

⚠ WARNING

- Ⓞ **Servicing must be performed by Christie service personnel or a Christie authorized service provider. Use replacement parts that are manufacturer-approved only. Use of any other part other than the ones specified by the manufacturer can result in fire, electric shock or risk of personal injury and irreparable equipment damage.**
- Ⓞ **DO NOT service the Christie MicroTiles while they are still connected. There are exposed voltages that could cause severe physical injuries and possibly death.**
- Ⓞ **DO NOT operate with heat sinks removed.**
- Ⓞ **Ensure the tile(s) is disconnected from AC power before testing, removing, or installing modules.**
- Ⓞ **DO NOT operate the tile(s) with any internal part removed.**
- Ⓞ **Any time the actuator is removed the opening in the housing must be covered with the plate.**

This document outlines the procedure required to remove the thermal actuator from the MicroTiles display unit. Each tile (P/N: 123-001102-01) is equipped with a thermal actuator, which activates when it reaches 40°C (104°F). When activated, the actuator extends, pushing the bottom of the screen a small distance away from the display unit, thereby releasing any potential pressure build-up between screens due to expansion at high temperatures. When the temperature of the actuator returns below 40°C (104°F), it retracts. The screens may need to be pushed back into position. Some customers may elect to remove the thermal actuator and replace it with a small cover plate. Christie permits the permanent removal of the thermal actuator, as described in this instruction sheet without affecting the product warranty. If the tiles are properly installed, the gaps between the screens are sufficient to avoid screen collision within the non-operating environmental range specified for the screen. The upper limits of these non-operating ranges are as follows:

	Screen S100	Screen S200
Maximum non-operating temperature	50°C (122°F)	31°C (88°F)
Maximum non-operating relative humidity	85% non-condensing	60% non-condensing

NOTICE: *Christie is not liable for screen damage due to improper installation, or due to exposing the screens to environmental conditions outside their non-operating range.*

KITS REQUIRED

☐ 003-003949-01 Thermal Actuator Removal Kit

TOOLS REQUIRED

- #1 Phillips™ screwdriver
- #10 Torx Driver

INSTRUCTIONS

ACTUATOR REMOVAL

NOTICE: *The thermal actuator can ONLY be serviced from the front of the array.*

(Estimated Replacement Time: 5 minutes)

1. Remove the screen. For details, refer to the *MicroTiles User Manual (P/N: 020-100329-xx)*.
2. Use a #1 Phillips™ screwdriver to remove the 2 screws securing the lower duct cover.
3. Use a #10 torx driver to remove the 4 screws securing the thermal actuator to the display casing.
4. Remove the thermal actuator.

Remove Lower Duct Cover

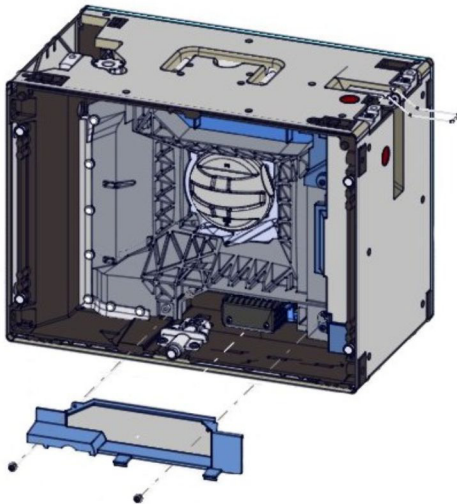

Remove Thermal Actuator

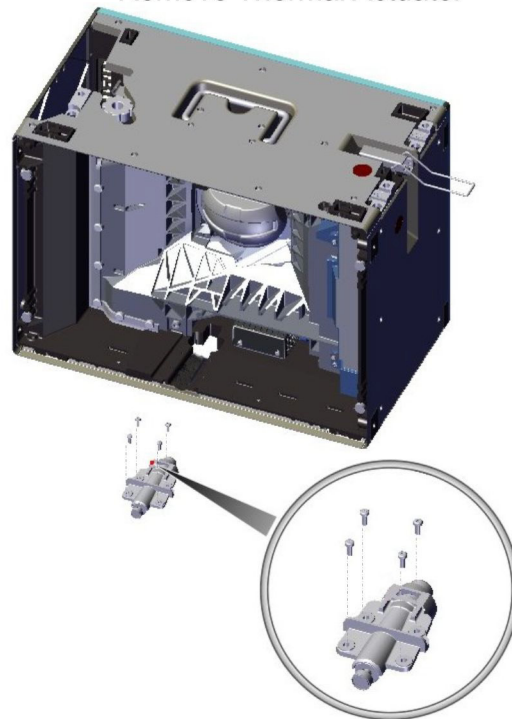

PLATE INSTALLATION

NOTICE: Any time the actuator is removed the opening in the housing must be covered with the plate.

1. Secure the plate (P/N: 011-104019-01) to the tile housing using a #10 torx driver to tighten the 4 screws.
2. Secure the lower duct cover using a #1 Phillips™ screwdriver to tighten the 2 screws.
3. Replace the screen. For details, refer to the *MicroTiles User Manual (P/N: 020-100329-xx)*.

