

Christie Vive Audio CDA2/CDA3 Amplifiers

User Manual

020-100355-02

CHRISTIE®

Christie Vive Audio CDA2/CDA3 Amplifiers

User Manual

020-100355-02

NOTICES

COPYRIGHT AND TRADEMARKS

Copyright © 2013 Christie Digital Systems USA Inc. All rights reserved.

All brand names and product names are trademarks, registered trademarks or trade names of their respective holders.

GENERAL

Every effort has been made to ensure accuracy, however in some cases changes in the products or availability could occur which may not be reflected in this document. Christie reserves the right to make changes to specifications at any time without notice. Performance specifications are typical, but may vary depending on conditions beyond Christie's control such as maintenance of the product in proper working conditions. Performance specifications are based on information available at the time of printing. Christie makes no warranty of any kind with regard to this material, including, but not limited to, implied warranties of fitness for a particular purpose. Christie will not be liable for errors contained herein or for incidental or consequential damages in connection with the performance or use of this material. Canadian manufacturing facility is ISO 9001 and 14001 certified.

WARRANTY

Products are warranted under Christie's standard limited warranty, the complete details of which are available by contacting your Christie dealer or Christie. In addition to the other limitations that may be specified in Christie's standard limited warranty and, to the extent relevant or applicable to your product, the warranty does not cover:

- a) Problems or damage occurring during shipment, in either direction.
- b) Projector lamps (See Christie's separate lamp program policy).
- c) Problems or damage caused by use of a projector lamp beyond the recommended lamp life, or use of a lamp other than a Christie lamp supplied by Christie or an authorized distributor of Christie lamps.
- d) Problems or damage caused by combination of a product with non-Christie equipment, such as distribution systems, cameras, DVD players, etc., or use of a product with any non-Christie interface device.
- e) Problems or damage caused by the use of any lamp, replacement part or component purchased or obtained from an unauthorized distributor of Christie lamps, replacement parts or components including, without limitation, any distributor offering Christie lamps, replacement parts or components through the internet (confirmation of authorized distributors may be obtained from Christie).
- f) Problems or damage caused by misuse, improper power source, accident, fire, flood, lightening, earthquake or other natural disaster.
- g) Problems or damage caused by improper installation/alignment, or by equipment modification, if by other than Christie service personnel or a Christie authorized repair service provider.
- h) Problems or damage caused by use of a product on a motion platform or other movable device where such product has not been designed, modified or approved by Christie for such use.
- i) Problems or damage caused by use of a projector in the presence of an oil-based fog machine or laser-based lighting that is unrelated to the projector.
- j) For LCD projectors, the warranty period specified in the warranty applies only where the LCD projector is in "normal use" which means the LCD projector is not used more than 8 hours a day, 5 days a week.
- k) Except where the product is designed for outdoor use, problems or damage caused by use of the product outdoors unless such product is protected from precipitation or other adverse weather or environmental conditions and the ambient temperature is within the recommended ambient temperature set forth in the specifications for such product.
- l) Image retention on LCD flat panels.
- m) Defects caused by normal wear and tear or otherwise due to normal aging of a product.

The warranty does not apply to any product where the serial number has been removed or obliterated. The warranty also does not apply to any product sold by a reseller to an end user outside of the country where the reseller is located unless (i) Christie has an office in the country where the end user is located or (ii) the required international warranty fee has been paid.

The warranty does not obligate Christie to provide any on site warranty service at the product site location.

PREVENTATIVE MAINTENANCE

Preventative maintenance is an important part of the continued and proper operation of your product. Please see the Maintenance section for specific maintenance items as they relate to your product. Failure to perform maintenance as required, and in accordance with the maintenance schedule specified by Christie, will void the warranty.

REGULATORY (if applicable)

The product has been tested and found to comply with the limits for a Class A digital device, pursuant to Part 15 of the FCC Rules. These limits are designed to provide reasonable protection against harmful interference when the product is operated in a commercial environment. The product generates, uses, and can radiate radio frequency energy and, if not installed and used in accordance with the instruction manual, may cause harmful interference to radio communications. Operation of the product in a residential area is likely to cause harmful interference in which case the user will be required to correct the interference at the user's own expense.

CAN ICES-3 (A) / NMB-3 (A)

이 기기는 업무용(A급)으로 전자파적합등록을 한 기기이오니 판매자 또는 사용자는 이점을 주의하시기 바라며, 가정 외의 지역에서 사용하는 것을 목적으로 합니다.

ENVIRONMENTAL

The product is designed and manufactured with high-quality materials and components that can be recycled and reused. This symbol



means that electrical and electronic equipment, at their end-of-life, should be disposed of separately from regular waste. Please dispose of the product appropriately and according to local regulations. In the European Union, there are separate collection systems for used electrical and electronic products. Please help us to conserve the environment we live in!

Table of Contents

Important Safety Information	1
Introduction.....	3
Overview	3
Features	3
What's In the Box?	4
Controls and Indicators	4
Front Panel	4
Rear Panel	5
Installation.....	7
Install the CDA2 or CDA3.....	7
Input Connections.....	7
Stereo Mode Connections	8
ParallelMode Connections.....	8
Output Connections.....	8
Stereo Mode Connections	9
Biamp Mode Connections	9
Bridge Mode Connections	10
Operation.....	10
Turn the Power On	10
Turn the Power Off	11
Troubleshooting.....	13
Specifications	15
Audio	15
Connections.....	15
Power	16
Block Diagram	17
Physical	17

Important Safety Information

Read this information thoroughly and completely before installing or operating Christie Vive Audio CDA2/CDA3 Professional Power Amplifiers.

- Read these instructions.
- Keep these instructions.
- Heed all warnings.
- Follow all instructions.
- Do not use this apparatus near water.
- Clean only with a dry cloth.
- Do not block any ventilation openings. Install in accordance with the manufacturer's instructions.
- Do not install near any heat sources such as radiators, heat registers, stoves, or other devices (including amplifiers) that produce heat.
- Do not defeat the safety purpose of the polarized or grounding-type plug. A polarized plug has two blades with one wider than the other. A grounding type plug has two blades and a third grounding prong. The wide blade or the third prong are provided for your safety. If the provided plug does not fit into your outlet, consult an electrician for replacement of the obsolete outlet.
- Protect the power cord from being walked on or pinched (particularly at plugs, convenience receptacles, and the point from where they exit the apparatus).
- Only use attachments or accessories specified by the manufacturer.
- Use only with the cart, stand, tripod, bracket, or table specified by the manufacturer, or sold with the apparatus. When a cart is used, use caution when moving the cart and apparatus combination to avoid injury from tip-over.
- Unplug this apparatus during lightning storms or when unused for long periods of time.
- To reduce the risk of electric shock, disconnect the AC power cord to completely remove power from the unit before repair or maintenance.
- All servicing must be completed by qualified service personnel. Servicing is required when the apparatus has been damaged in any way, such as power-supply cord or plug is damaged, liquid has been spilled or objects have fallen into the apparatus, the apparatus has been exposed to rain or moisture, does not operate normally, or has been dropped.
- Changes or modifications to this unit not expressly approved by the party responsible for compliance could void the user's authority to operate the equipment.
- Provide rear support if this product is mounted in an equipment rack.
- Do not install the amplifier near water where the electrical components can be exposed to moisture. Do not place objects containing liquids, such as vases, on the product.
- Provide proper ventilation. Allow 31 cm (12 in.) clearance from the nearest combustible surface. Make sure that vents are not blocked and that air can flow freely through the unit.
- Make sure that vents are not blocked and that air can flow freely through the unit.

- The power switch does not break both sides of the primary mains. Hazardous energy can be present inside the chassis when the power switch is in the off position. The mains plug or appliance coupler is used as the disconnect device. The disconnect device shall remain readily operable.
- Exposure to extremely high noise levels may cause permanent hearing loss. Individuals vary considerably in their susceptibility to noise-induced hearing loss, but nearly everyone will lose some hearing if exposed to sufficiently intense noise for a sufficient time. These are the permissible noise level exposures specified by the United States Occupational Safety and Health Administration (OSHA):

Duration (Consecutive)	Sound Level (dBA), Slow Response
8 hrs	90
6 hrs	92
4 hrs	95
3 hrs	97
2 hrs	100
1.5 hrs	102
1 hr	105
30 min	110
≤15 min	115

According to the OSHA, any exposure in excess of the above permissible limits could result in some hearing loss. Earplugs or protectors to the ear canals or over the ears must be worn when operating this amplification system to prevent permanent hearing loss, if exposure is in excess of the described limits.

TECHNICAL SUPPORT

Contact your dealer or technical support for questions relating to unclear information, malfunctions, or product repairs.

Americas

Email: tech-support@christiedigital.com

Phone:

- Canada and USA: +1-800-221-8025
- Chile: 519-744-8005

Europe, Middle East, and Africa

Email: techsupport-emea@christiedigital.com

Phone:

- Russia: +7 (495) 930 8961
- Eastern Europe: +36 (0)1 47 48 100
- France: +33 (0) 1 41 21 44 10
- Germany: +49 2161 56620 22
- Italy: +39 (0) 2 9902 1161
- Africa: +27 (0) 11 510 0094
- Spain: +34 91 633 9990
- Middle East: +971 (0) 4 320 6688
- United Kingdom: +44(0) 118 977 8111

Asia Pacific

Email: tech-asia@christiedigital.com

Phone:

- Australia: +61 (0) 7 3624 48888
- China: +86 10 6561 0240
- India: +91 (080) 6708 9999
- Japan: 81-3-3599-7481
- South Korea: +82 2 702 1601
- Singapore: +65 6877-8737

Introduction

This user manual provides data about the Christie Vive Audio CDA2/CDA3 Professional Power Amplifiers controls, installation, and specifications.

Overview

Christie Vive Audio CDA2/CDA3 Professional Power Amplifiers utilize an advanced design that reduces the weight of the amplifier significantly while increasing output power, reliability, and thermal efficiency.

Christie Vive Audio CDA2/CDA3 Professional Power Amplifiers are designed with a resonant switch-mode power supply and a high-speed class D topology that yields superior audio resolution and efficiency. Advanced technology and extensive protection circuitry allow operation with greater efficiency into difficult loads and power conditions. The ACL (Automatic Clip Limiting) circuitry provides trouble-free operation into loads as low as 2 ohms. ACL protects loudspeaker drivers and ensures that sonic integrity is maintained, even in extreme overload conditions. The CDA's high-efficiency design allows the amplifier to operate at very low temperatures, and does not require massive heat sinks for cooling.

Features

- Two channel-independent, fourth order Linkwitz-Riley crossovers
- Automatic Clip Limiting (ACL) protection
- Revolutionary CDA Class-D power regulation topology
- Detented input controls
- Combination XLR - 6.3 mm (1/4 in.) inputs
- Twist-lock connector outputs
- Ultra-lightweight
- 4-pole connection of channel A output for simplified speaker bi-amplification

What's In the Box?

Quantity	Description	Part Number
1	Christie Vive Audio CDA2 Professional Amplifier 100V -or- Christie Vive Audio CDA2 Professional Amplifier 120V -or- Christie Vive Audio CDA2 Professional Amplifier 230V -or- Christie Vive Audio CDA3 Professional Amplifier 100V -or- Christie Vive Audio CDA3 Professional Amplifier 120V -or- Christie Vive Audio CDA3 Professional Amplifier 230V	145-005106-XX 145-001102-XX 145-009100-01 145-006107-01 145-002103-01 145-010102-01
1	Power Cord	The included power cord is specific for each region. Please check the box to ensure you have the correct one.

Controls and Indicators

This section provides an overview of the Christie Vive Audio CDA2/CDA3 Professional Power Amplifiers components.

Front Panel



Letter	Component	Description
A	Input Gain Control	Adjusts the gain for their respective amplifier channel (Ch.A or Ch.B) in all modes. The recommended nominal setting is -10dB.

B	Indicators	<p>Indicates the operating status of each of the channels and warns of possible malfunction. There are 5 indicators for each channel:</p> <ul style="list-style-type: none"> • ACL (automatic clip limiting) - indicates clipping. If the light is flashing quickly and intermittently, the channel is at the clip threshold. Gain reduction is automatically employed to prevent severely clipped waveforms from reaching the loudspeakers. • SIG (signal) - indicates that an output signal of 4 volts RMS or more (0.1 volt or more at the input with 0 dB attenuation and standard x 40 voltage gain) is being produced by the channel. The signal is reaching and being amplified by the amplifier. • TEMP (temperature) - indicates an unstable thermal condition. The amplifier protection will activate and shut down the affected channel. The light will remain illuminated until a safe operating temperature is achieved. • DC (direct current) - indicates abnormal operating conditions. The light illuminates when conditions arise that will damage the loudspeaker driven by that channel. The amplifier automatically attempts to restart to correct the condition. If the amplifier does not return to a normal operating status, contact your local authorized service center. • ACTIVE - indicates that the channel is operational. The light illuminates under normal operation and remains on, even when the channel is in ACL gain reduction. If the light is off, there is no signal at the output connectors.
C	AC Power Switch	Turns the power on and off. This is a combination magnetic circuit breaker and switch.
D	Rack Mounting Ears	Provides mounting holes for rack installation.

Rear Panel



If the PARALLEL or BRIDGE input mode is selected, the signal input to channel A of the power amp is also available as an output on the channel B input connector. This allows you to patch input signals between multiple amplifiers.

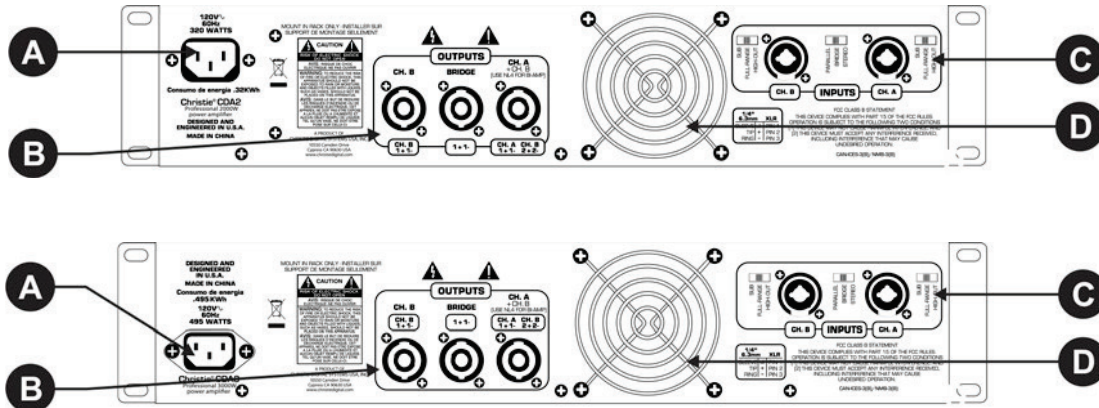

Letter	Component	Description
A	AC Power Inlet	Provides AC power to the amplifier. Connect the IEC line cord to this connector to provide power to the amplifier.
B	Outputs	Provides the connecting and bridge outputs:

		<ul style="list-style-type: none"> • CH. B - allows a twist lock connector to be connected to the channel B output. • BRIDGE - allows for a twist lock connector to be connected to the bridged amplifier output. • CH. A - allows a 2-pole or 4-pole twist lock connector to be connected to the channel A output. Connecting a 4-pole twist lock connector provides the outputs of both channels A and B on the corresponding poles of the 4-pole connector.
C	Inputs	<ul style="list-style-type: none"> • Provides the connecting inputs and input controls. Input connections are made using the 3-pin XLR (pin 2+) or 6.3 mm (1/4 in.) plug combination connectors on the rear panel of the amplifier. The inputs are actively balanced. <p>The following channel modes are available:</p> <ul style="list-style-type: none"> • SUB (subwoofer) - activates the low pass filter for the corresponding channel. This Linkwitz-Riley filter limits the frequencies sent to the associated amplifier channel to those frequencies below 100 Hz. In situations where separate subwoofer cabinets are being used, this position indicates connecting the subwoofer speaker cabinet to the channel associated with the subwoofer switch. • FULL-RANGE - allows all frequencies to pass to the amplifier. This setting is normally used when connecting a full range speaker enclosure to the amplifier's output. • HIGH-OUT (switch high pass) - activates the high pass filter for the corresponding channel. This Linkwitz-Riley filter limits the frequencies sent to the associated amplifier channel to those frequencies above 100 Hz. In situations where separate subwoofer cabinets are being used, this position would indicate connecting the mid-high frequency speaker cabinet to the channel associated with the high pass switch. <p>The following channel input mode switches are available:</p> <ul style="list-style-type: none"> • PARALLEL - routes the signal input of channel A to both channel A and channel B outputs. Use this to route the single input signal to each of the discrete amplifier outputs. • BRIDGE - combines both amplifier channels together for a powerful single-channel amplifier. Routes the signal connected to channel A input to the bridged amplifier channels. This is required when the single input signal is to be routed as the bridged amplifier output. • STEREO - provides independent channel operation. Routes the signal connected to channel A input to the amplifier channel A output and the signal connected to channel B input to the amplifier channel B output. This is required when discrete inputs to channels A and B should be routed to the corresponding amplifier outputs. <p>Do not adjust the mode when the amplifier is turned on.</p>
D	Variable Speed 80mm DC Fan	<p>Provides air flow through the cooling fins of the channel heat-sinks, to dissipate the heat of the power devices. Air exhausts through the front panel slots. Fan speed is automatically controlled; the fan speed increases as the heat-sink temperature rises, and slows as the temperature lowers. Make sure these vents remain clear to allow unrestricted air flow.</p> <p>If a channel's heat-sink surpasses the maximum temperature limit, the high temperature sensing circuit will idle the channel until a safe operating temperature is restored. If the power supply overheats, the high temperature sensing circuit will idle both channels until a safe operating temperature is restored.</p>

Installation

This section provides information and procedures for installing and connecting the Christie Vive Audio CDA2/CDA3 Professional Power Amplifiers.

Install the CDA2 or CDA3

WARNING

An incorrect power setup creates a fire and shock hazard. Do not attempt operation unless the power cord, power socket, and power plug meet the appropriate local rating standards. Have a certified electrician install a permanent single-phase connection from the amplifier to the AC supply for correct installation. Failure to comply could result in death or serious injury.

NOTICE

Always provide proper ventilation to the Christie Vive Audio CDA2/CDA3 Professional Power Amplifiers. Allow 31 cm (12 in.) clearance at the front and the back of the amplifier. Make sure that vents are not blocked and that air can flow freely through the unit. Do not use doors or covers on the front of the rack. If a back cover is used, provide at least one standard rack-space opening for every 4 amplifiers. Failure to comply may result in equipment or property damage.

1. Slide the CDA2 or CDA3 amplifier into your rack.
2. Secure the amplifier in position using 4 screws through the rack mounting ears.
3. Connect one end of the power cord to the AC power inlet and the other end to the power outlet.
4. Connect the output and input connectors.
See [Output Connections](#) on page 9, and [Input Connections](#) on page 8.
5. Turn the power on.
See [Turn the Power On](#) on page 10.

Input Connections

NOTICE

Always turn off and disconnect the Christie Vive Audio CDA2/CDA3 Professional Power Amplifiers from power before making audio connections. Failure to comply may result in equipment or property damage.

This section describes the input connections of the Christie Vive Audio CDA2/CDA3 Professional Power Amplifiers.

Stereo Mode Connections

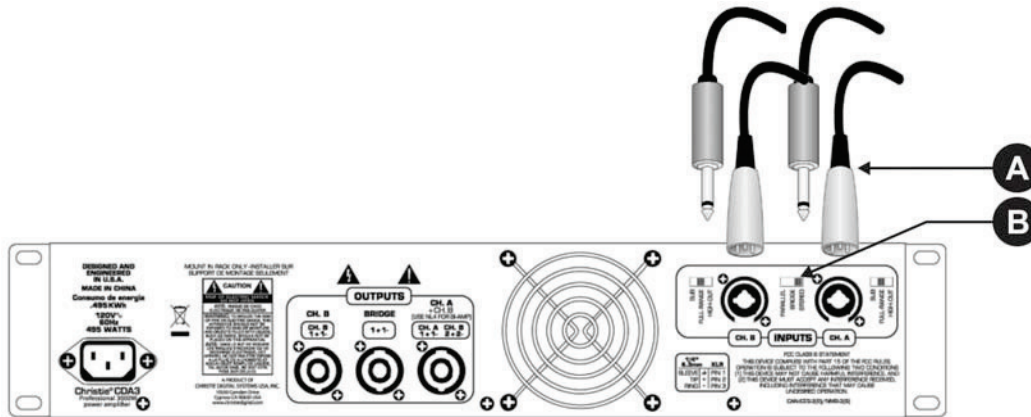

A	3-pin XLR, or 6.3 mm (1/4 in.) phono jacks connected to the CH. A and CH. B INPUTS	B	Input selector set to STEREO
----------	--	----------	------------------------------

Parallel Mode Connections

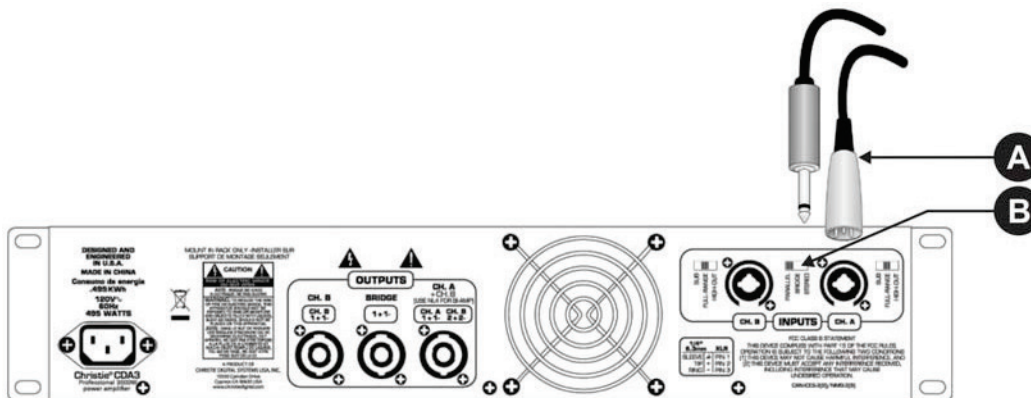

A	3-pin XLR, or 6.3 mm (1/4 in.) phono jacks connected to the CH. A INPUTS	B	Input selector set to PARALLEL
----------	--	----------	--------------------------------

Output Connections

NOTICE

Always turn off and disconnect the Christie Vive Audio CDA2/CDA3 Professional Power Amplifiers from power before making audio connections. Failure to comply may result in equipment or property damage.

This section describes the output connections of the Christie Vive Audio CDA2/CDA3 Professional Power Amplifiers.

Stereo Mode Connections

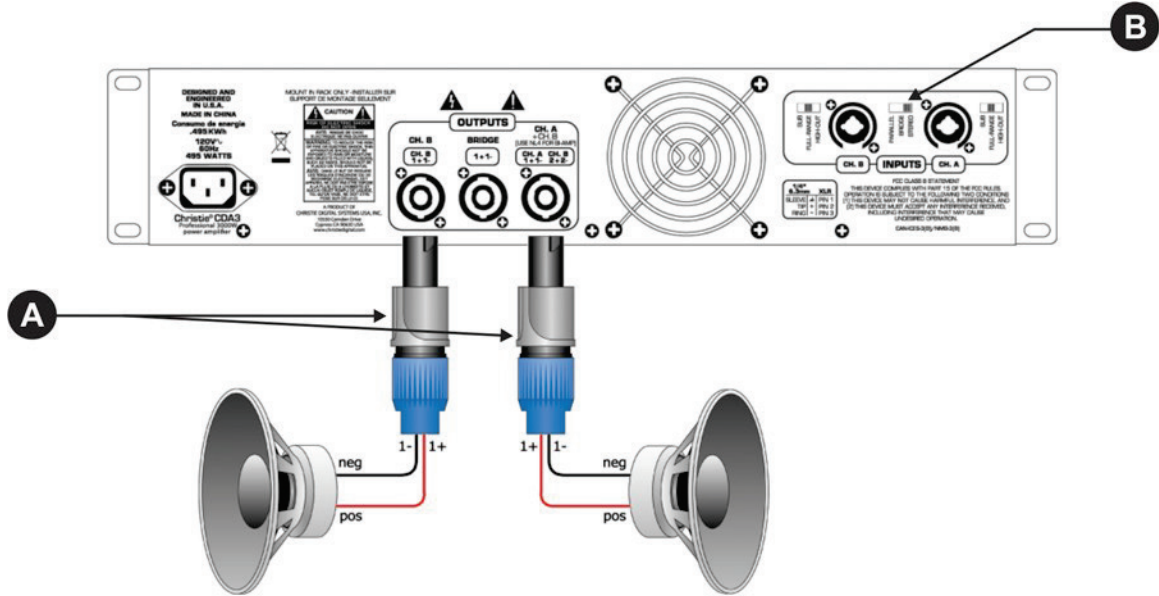

A	NL2 twist-lock connectors connected to CH. A and CH. B OUTPUTS	B	Input selector set to STEREO
----------	--	----------	------------------------------

Biamp Mode Connections

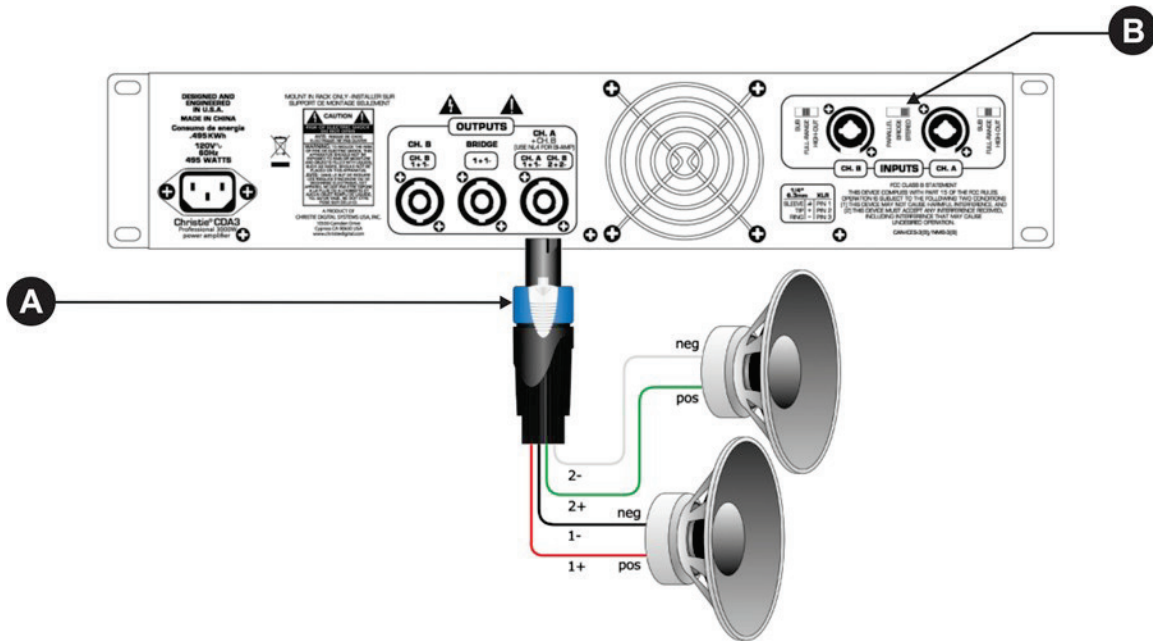

A NL4 twist-lock connector connected to CH. A. OUTPUTS	B Input selector set to STEREO
---	---------------------------------------

Bridge Mode Connections

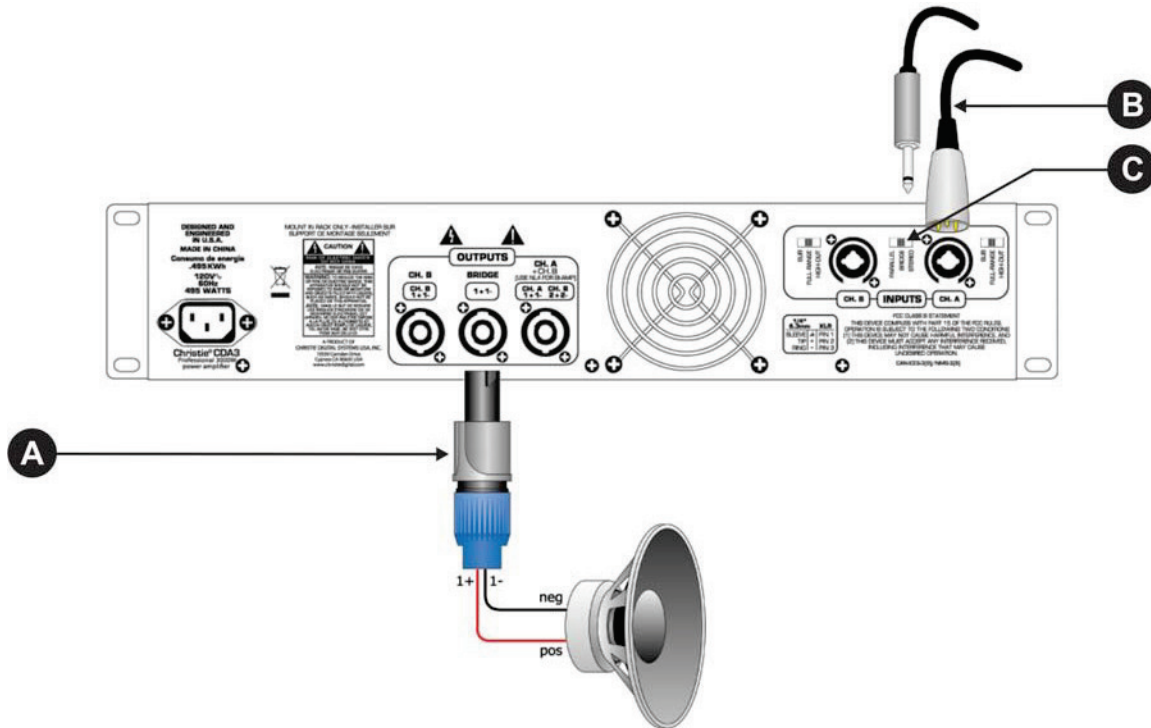

A NL2 twist-lock connector connected to the BRIDGE OUTPUTS	B 3-pin XLR, or 6.3 mm (1/4 in.) phono jacks connected to the CH. A INPUTS
C Input selector set to BRIDGE	

Operation

Turn the Power On

⚠ WARNING

- Use only the AC power cord that is provided. DO NOT attempt operation if the AC supply is not within the specified voltage and power range. Failure to comply could result in death or serious injury.
- As a safety feature, the amplifier is equipped with a three-wire plug with a third (grounding) pin. If you are unable to insert the plug into the outlet, contact an electrician to have the outlet replaced. DO NOT defeat the safety purpose of the grounding-type plug. Failure to comply could result in death or serious injury.
- DO NOT attempt operation if the AC supply is not within the rated voltage range as specified on the license label. For power requirements, see Power on page 16. Failure to comply could result in death or serious injury.
- Disconnect amplifier from AC before opening any enclosure. Failure to

comply could result in death or serious injury.

- Only qualified service technicians are permitted to open enclosures and only if the amplifier is disconnected from AC power. Failure to comply could result in in death or serious injury.

CAUTION

- DO NOT allow anything to rest on the power cord. Locate the amplifier where the cord cannot be damaged by persons walking on it or objects rolling over it. Never operate the amplifier if the power cable appears damaged in any way. Failure to comply could result in in death or serious injury.
- DO NOT overload power outlets and extension cords as this can result in fire or shock hazards. Failure to comply could result in in death or serious injury.

1. Verify that the power cord is connected and that the amplifier settings are as required.
2. Move the AC power switch to the on position.

Turn the Power Off

Move the AC power switch to the off position.

Troubleshooting

This section provides basic Christie Vive Audio CDA2/CDA3 Professional Power Amplifiers troubleshooting information.

CAUTION

Do not service the amplifier yourself. Contact a qualified service technician.

Problem	Resolution
<p>The amplifier power will not turn on.</p>	<ul style="list-style-type: none"> • Verify that the amplifier is receiving power. Plug the amplifier into the AC mains. Connect the IEC line cord to the AC power inlet on the rear panel of the amplifier. • Verify that the circuit breaker for the mains circuit is open. Reset the circuit breaker, then turn the amplifier power on again. If the AC mains breaker continues to open, check the voltage and amperage (d) of the circuit. • Verify that the circuit breaker has the correct voltage and amperage (d). If required, have a qualified electrician replace the circuit breaker. If the circuit breaker continues to open, send the amplifier to an authorized service center for repair.
<p>The amplifier power is on, but there is no sound from the loudspeakers.</p>	<ul style="list-style-type: none"> • Check the amplifier indicators: <ul style="list-style-type: none"> • If the ACTIVE indicators are lit for each channel, verify that the amplifier is receiving power. See The amplifier power will not turn on. on page 13. • If the SIG (signal) indicators are lit or blinking, check the level of the input signal source. • If the TEMP (temperature) indicators are lit for either channel, the amplifier has overheated and idled one or both channels. See The amplifier is overheating. on page 14. • If the DC (direct current) indicators are lit for either channel, an abnormal condition exists within the amplifier or the load it is driving. If the channel does not reset and the DC indicators remain lit, send the amplifier to an authorized service center for repair. • Check the amplifier mode: <ul style="list-style-type: none"> • If the amplifier is in PARALLEL or BRIDGE mode and the input signal is connected to CH B, connect the input signal to CH A. See Input Connections on page 8. • If the amplifier is in BRIDGE mode and the output connections are made to CH A or CH B, use the center BRIDGE output connector to connect the loudspeaker. See Bridge Mode Connections on page 11. • Verify that the attenuators on the front panel are turned up. Turn the attenuators up until you hear output from the loudspeakers. • Check all connections between the amplifier and loudspeakers. Make sure that the twist lock connectors are fully-inserted and seated. The connectors must be inserted and turned 1/4" clockwise until they lock in position. If screw terminal connections are used at the loudspeaker inputs, make sure the cables are attached and do not cause a short between the poles of the loudspeaker inputs. • Inspect the loudspeaker cables and repair any shorts or breaks in the cables, or replace the cables. • Inspect all loudspeaker cable connection terminations to make sure

	<p>they are complete and wired correctly. Verify the polarity of each connection.</p>
<p>There is output from one channel, but not from the other channel.</p>	<ul style="list-style-type: none"> • Verify that the attenuators are turned up for both channels. • Check all connections between the amplifier and loudspeakers. Make sure that the twist lock connectors are fully-inserted and seated. The connectors must be inserted and turned 1/4" clockwise until they lock in position. If screw terminal connections are used at the loudspeaker inputs, make sure the cables are attached and do not cause a short between the poles of the loudspeaker inputs. • Check the amplifier indicators: <ul style="list-style-type: none"> • If the SIG (signal) indicators are lit or blinking for both channels, make sure the channel's input signal is present and at a sufficient level to drive the input. • If the TEMP (temperature) indicators are lit for either channel, the amplifier has overheated and idled one or both channels. See The amplifier is overheating on page 14. • If the DC (direct current) indicators are lit for either channel, an abnormal condition exists within the amplifier or the load it is driving. If the channel does not reset and the DC indicators remain lit, send the amplifier to an authorized service center for repair. • Check the amplifier mode: <ul style="list-style-type: none"> • If the amplifier is in STEREO mode, make sure there is signal input to CH A and CH B. See Input Connections on page 8. • If the amplifier is in STEREO or PARALLEL mode, make sure that one of the loudspeaker connections is not connected to the BRIDGE output.
<p>There is sound output from the loudspeakers, but there are no high frequencies present in the output.</p>	<ul style="list-style-type: none"> • Check if the low-pass filter is engaged on either channel. Make sure the input mode selector switch is set to the correct mode (Full Range is the default mode). • Verify that the NL4 twist-lock connector is wired correctly if the loudspeaker is biamped through the CH A output connection. See Biamp Mode Connections on page 10.
<p>There is sound output from the loudspeakers, but there are no low frequencies present in the output.</p>	<ul style="list-style-type: none"> • Check if the high-pass filter is engaged on either channel. Make sure the input mode selector switch is set to the correct mode (Full Range is the default mode). • Verify that the NL4 twist-lock connector is wired correctly if the loudspeaker is biamped through the CH A output connection. See Biamp Mode Connections on page 10.
<p>The amplifier is overheating.</p>	<ul style="list-style-type: none"> • Verify that there is adequate ventilation around the amplifier. Make sure there is 31 cm (12 in.) clearance at the front and the back of the amplifier. • Verify that the amplifier cooling vents are not blocked. • Check the cooling fan at the rear panel of the amplifier to make sure it is working. If the power amplifier has overheated, the TEMP indicators are lit, and the fan is not operating, cease operation of the amplifier and send it to an authorized service center for repair. • Verify that the amplifier is operating within its rated impedance. Check the loudspeaker load being presented to the amplifier outputs. The minimum load impedance for the CDA2 and CDA3 power amplifier is 2 ohms. Loudspeaker loads below 2 ohms stereo (4 ohms for each channel) or 4 ohms bridged cause the amplifier to overheat. If overloaded, correct the loudspeaker configuration or load the resume operation.

Specifications

This section provides Christie Vive Audio CDA2/CDA3 Professional Power Amplifiers specifications.

Audio

Specification	CDA2 Value	CDA3 Values
Input common mode rejection ratio (CMRR)	> -69 dB @ 1kHz	> -76dB @ 1kHz
Voltage gain	x60 (+35dB)	x75 (+37dB)
Crossover	100Hz switchable 2nd order high pass and 3rd order low pass per channel	100Hz switchable 2nd order high pass and 3rd order low pass per channel
Crosstalk	> -70dB @ 1kHz @ 250 watts power @ 8 ohms	> -70dB @ 1kHz @ 100 watts power @ 8 ohms
Hum and noise	> -100dB, "A" weighted reference to rated power @ 4 ohms	> -100dB, "A" weighted reference to rated power @ 4 ohms
Slew rate	> 12V/μs	> 12V/μs
Damping factor (8 ohms)	> 170:1 @ 20Hz – 1kHz @ 8 ohms	> 255:1 @ 20Hz – 1kHz @ 8 ohms
Input sensitivity	0.775 volts +/- 3% for 1kHz 4 ohm rated power, 35 volts +/- 3% for 1kHz 2 ohm rated power	0.740 volts +/- 3% for 1kHz 4 ohm rated power, 0.71 volts +/- 3% for 1kHz 2 ohm rated power
Input impedance	15k ohms, balanced and 7.5k ohms, unbalanced	15k ohms, balanced and 7.5k ohms, unbalanced
Protection	<ul style="list-style-type: none"> • Thermal • DC • Subsonic • Incorrect loads • Under and over voltage 	<ul style="list-style-type: none"> • Thermal • DC • Subsonic • Incorrect loads • Under and over voltage

Connections

Specification	CDA2 Value	CDA3 Values
Inputs	Dual combination 6.3 mm (1/4 in.) and XLR	Dual combination 6.3 mm (1/4 in.) and XLR
Outputs	(3) 4-pin twist-lock connectors for 2 channels plus bridge	(3) 4-pin twist-lock connectors for 2 channels plus bridge

Power

Specification ¹		CDA2 Value	CDA3 Values
Input power requirement		120V~; 60Hz; 320W, Class I	120V~; 60Hz; 495W, Class I
		220-240V~; 50/60Hz; 320W, Class I	220-240V~; 50/60Hz; 495W, Class I
		100V~; 60Hz; 320W, Class I	100V~; 60Hz; 495W, Class I
Rated power	Bridged at 4 ohms	2,100 watts 20 ms repetitive burst/ 1,950 watts @ 1kHz 1% THD	3,640 watts 20ms repetitive burst/ 3,000 watts 1% THD @ 1kHz
	Bridged at 8 ohms	N/A	2,000 watts 20ms repetitive burst/ 1,550 watts 0.15% THD @ 1kHz
	2 chs x 2 ohms	1,100 watts 20 ms repetitive burst/ 900 watts 1% THD both channels driven @ 1kHz	1,820 watts 20ms repetitive burst/ 1,500 watts 1% THD both channels driven @ 1Khz
	2 chs x 4 ohms	600 watts 20ms repetitive burst/570 watts 1% THD/530 watts 0.15% THD, both channels driven @ 1Khz	1,000 watts 20ms repetitive burst/900 watts 1% THD/830 watts 0.15% THD, both channels driven @ 1 KHz
	2 chs x 8 ohms	370 watts 20ms repetitive burst/325 watts 1% THD/300 watts 0.15% THD, both channels driven @ 1 KHz	540 watts 20ms repetitive burst/500 watts 1% THD/450 watts 0.15% THD, both channels driven @ 1 kHz
Minimum load impedance		2 ohms	2 ohms
Maximum RMS voltage swing		56 volts	71 volts
Frequency Response		10Hz – 30kHz: +/- 3 dB at 1 watt, 8 ohms	20Hz – 28kHz: +0dB, -3.0 dB at 1 watt
20 Hz	20kHz, 2 chs x 2 ohms	<0.25% @ 800 watts 20Hz to 4kHz, decreasing to 760 watts @ 20kHz, both channels driven	<0.5% @ 1,350 watts 20Hz increasing to 1,380 watts @ 20kHz, both channels driven
	20kHz, 2 chs x 4 ohms	<0.15% @ 540 watts 20Hz to 20kHz, both channels driven	<0.15% @ 800 watts 20Hz increasing to 850 watts @ 20kHz, both channels driven
	20kHz, 2 chs x 8 ohms	<0.15% @ 300 watts 20Hz to 10kHz, both channels driven	<0.15% @ 450 watts 20Hz increasing to 500 watts @ 20kHz, both channels driven
Current draw	1/8 power	540VA (315w) @ 2 ohms, 370VA (185w) @ 4 ohms, 240VA (115w) @ 8 ohms	960VA (540w) @ 2 ohms, 620VA (320w) @ 4 ohms, 400VA (190w) @ 8 ohms
	1/3 power	1,250VA (760w) @ 2 ohms, 750VA (425w) @ 4 ohms, 460VA (240w) @ 8 ohms	2,070VA (1,310w) @ 2 ohms, 1,220VA (700w) @ 4 ohms, 740VA (400w) @ 8 ohms
Idle consumption		90VA (40W)	140VA (60w)

¹. Rated power readings made with BW: 20Hz to 22kHz. All power measurements made @ 120VAC or 240VAC. 2ohm steady state sine wave power is time limited by circuit breaker.

Block Diagram

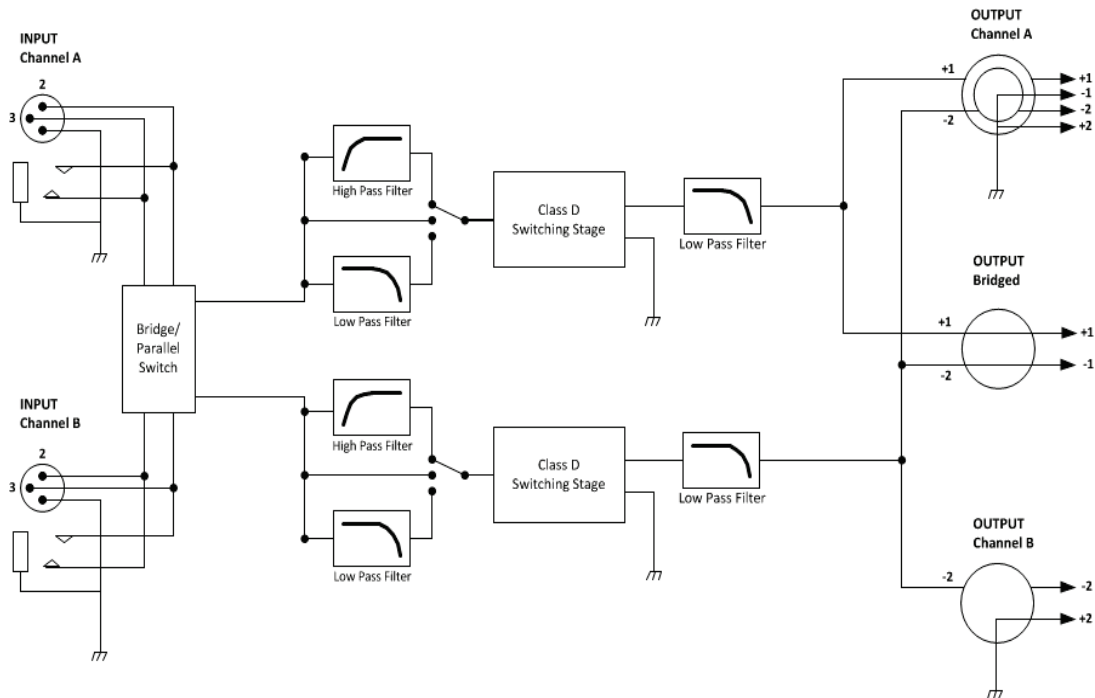

Physical

Specification	CDA2 Value	CDA3 Values
Enclosure	0.157 cm (0.062 in.) aluminum	18ga. galvanized steel
Dimensions (H x W x D)	8.9 cm x 48.3 cm x 26.7 cm (3.5 in.) x (19 in.) x (10.5 in.)	8.9 cm x 48.3 cm x 26.7 cm + 0.15 cm for handles (3.5 in.) x (19 in.) x (10.5 in.) + 0.6 in. for handles
Weight (net) ¹	4.94 kg (10.90 lb)	5.54 kg (12.2 lb)
Weight (gross) ²	6.02 kg (13.3 lb)	6.30 kg (13.9 lb)

¹ Net weight excludes the power cord.

² Gross weight excludes the power cord.



ASSY TECH DOCS VIVE CDA2-CDA3

Corporate offices

USA – Cypress
ph: 714-236-8610
Canada – Kitchener
ph: 519-744-8005

Worldwide offices

United Kingdom
ph: +44 118 977 8000
France
ph: +33 (0) 1 41 21 00 36
Germany
ph: +49 2161 664540

Eastern Europe
ph: +36 (0) 1 47 48 100
Middle East
ph: +971 (0) 4 299 7575
Spain
ph: + 34 91 633 9990

Singapore
ph: +65 6877-8737
Beijing
ph: +86 10 6561 0240
Shanghai
ph: +86 21 6278 7708

Japan
ph: 81-3-3599-7481
South Korea
ph: +82 2 702 1601

