

Line array and line source laser alignment procedures

Due to the directional nature of line array and line source speaker systems and their very wide horizontal and controlled vertical coverage, you must install and aim Christie Vive Audio speakers accurately during installation.

This provides optimal coverage for the entire listening area, while minimizing room reflection. Laser alignment is the easiest and most effective way for aiming directional speaker systems.

Precautions

Keep the following points in mind when laser aligning the speakers.

- Always use recommended mounting and installation methods and hardware with the required alignment capability for a given speaker in a given application. This allows proper aiming and acoustic performance for the speaker systems.
- Improper aiming of speakers can result in poor coverage of the listening area, especially at high and mid frequencies which are critical for clarity of content, especially dialog and perception of imaging effects and localization of sound.
- Improper aiming of speakers can direct sound energy towards room surfaces outside of the listening area, creating unnecessary reflections and reverberation, negatively impacting sound quality and the user experience.

Laser aligning speakers: Overview

The following topics provide some background information necessary before starting the laser alignment procedures.

Positioning a speaker behind a perforated screen

When installing speakers behind a perforated projection screen, the optimal distance from the top-front of the speaker to rear of projection screen is 150 mm (6 inches) (A) once the laser alignment procedure is complete.

This distance provides the best possible speaker performance behind a perforated screen.

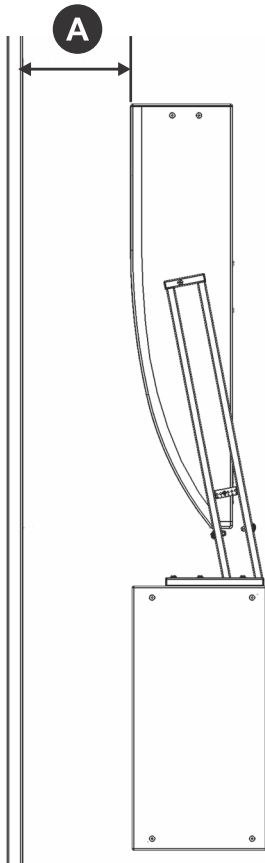

If this distance is not practical due to site conditions, maintain a distance of no less than 100 mm (4 inches) and no more than 300 mm (12 inches) between the top-front of the speaker and rear of the perforated screen, to avoid deterioration of audio performance.

Laser align speakers when installing them

It is most efficient to laser align, then secure speakers when installing them, using recommended methods.

Installation configurations include:

- Stacked on subwoofer using a tilt bracket
- Flown with a subwoofer using an L bracket and approved cables
- Flown individually with recommended cables
- Wall mounted (with a two axis wall mount bracket)
- Ceiling mounted (with a three axis ceiling mount)

Before performing a laser alignment, ensure that speakers are installed in correct locations using recommended methods and hardware, with the required adjustment capability.

Laser alignment tool

To laser align speakers, you must use a standard laser alignment and measurement tool, such as the Bosch GLR225 Laser Distance Measurer.

Positioning the laser alignment tool

Before aiming the speakers, you must learn the positions to place the laser alignment tool in.

Placing the laser alignment tool in position one

Use position one for pan (horizontal) angle adjustment.

1. Place the back of the laser alignment tool flat against the face of the ribbon driver.
2. Aim the laser beam 90° to the top, front edge of the speaker cabinet.
You may need to move the laser alignment tool up or down the ribbon driver array to find a position where the laser beam hits the pan adjustment target.

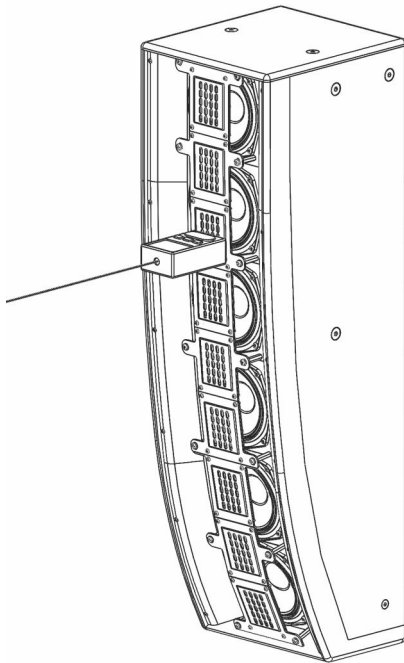

Placing the laser alignment tool in position two

Use position two for tilt (vertical) angle adjustment.

1. Place the laser alignment tool on top of the speaker, flush with the top front edge of the speaker cabinet.
2. Center the tool on the speaker with the laser beam aimed 90° to the top front edge of the speaker cabinet.

You can rotate the tool horizontally clockwise and counterclockwise, remaining flush with the top of the cabinet, to check the tilt angle and upper extent of the vertical coverage.

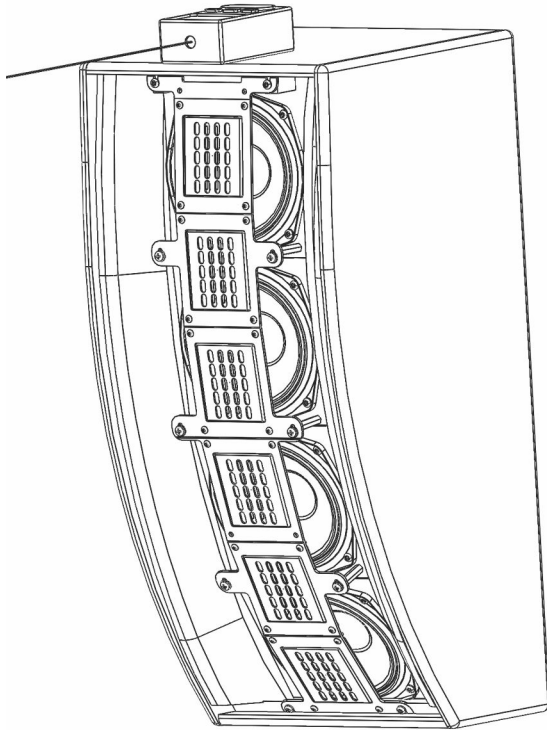

Placing the laser alignment tool in position three

Use position three for tilt and pan adjustment of line array ceiling surround speakers.

1. Place the back of the laser alignment tool flat against the rear most ribbon driver in the array.
2. Aim the laser beam 90° to the top rear edge of the speaker cabinet.

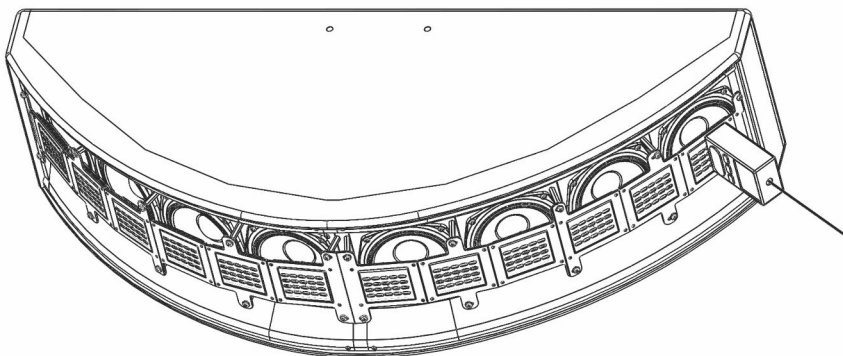

Aligning the screen channel speakers

Use the laser alignment tool to properly position the screen channel speakers.

1. Place the laser alignment tool in position one.
2. Pan (rotate horizontally) the speakers so that laser beam hits a target set up at the reference listening position (the point two-thirds of the distance to the back of the room, according to SMPTE ST202:2010 specifications).

In a typical installation scenario of a screen channel speaker mounted on a subwoofer using a tilt bracket, move the entire assembly on the platform when panning.

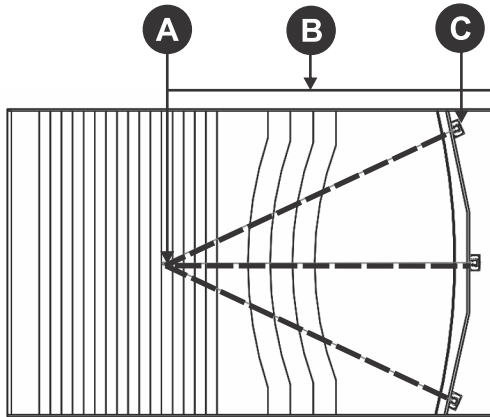

A	Reference listening position
B	2/3 of room length
C	Screen channel speaker

3. Lock the pan adjustment by either securing the assembly to the platform, or locking down the pan adjustment on the two-axis wall mount or recommended cables.
4. Place the laser alignment tool in position two.
5. Adjust the tilt of the speakers using the tilt bracket, wall mount, or recommended cables so that the laser beam hits the back wall, approximately 2.5 m (8 ft.) above the rear floor.

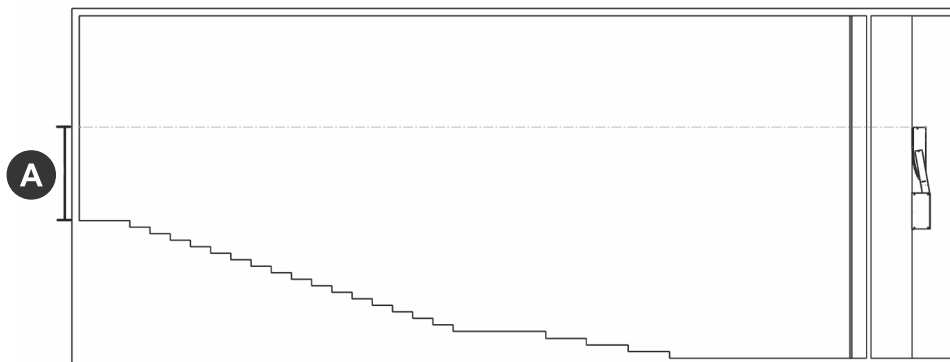

A	2.5 m (8 ft.)
---	---------------

6. Lock the tilt adjustment.

Aligning the wall channel speakers (basic method)

The basic method aligns the speakers to the reference listening position.

1. Place the laser alignment tool in position one against the side wall surround speakers.
2. Adjust the pan of the side wall surround speakers, using the two-axis wall mount brackets or recommended cables, so that the laser beam hits a target set up at the reference listening position.

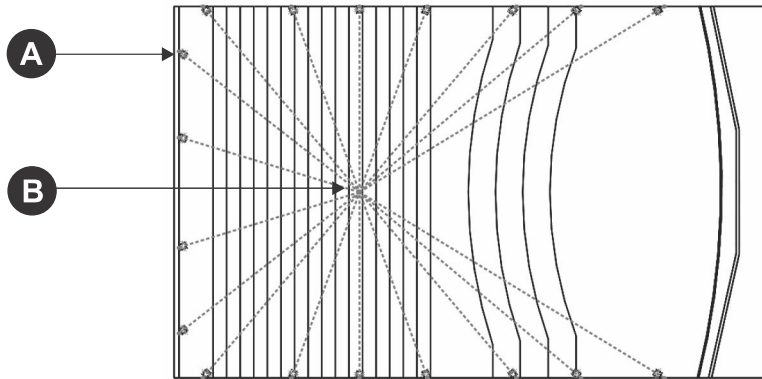

A	Wall surround speaker
B	Reference listening position

3. Lock the pan adjustment.
4. Place the laser alignment tool in position two against the side wall surround speakers.
5. Adjust the tilt of the side wall surround speakers, using the two-axis wall mount brackets or recommended cables, so that the laser beam hits the opposite wall approximately 2.5 m (8 ft.) above the floor.

You may need to rotate the laser alignment tool horizontally.

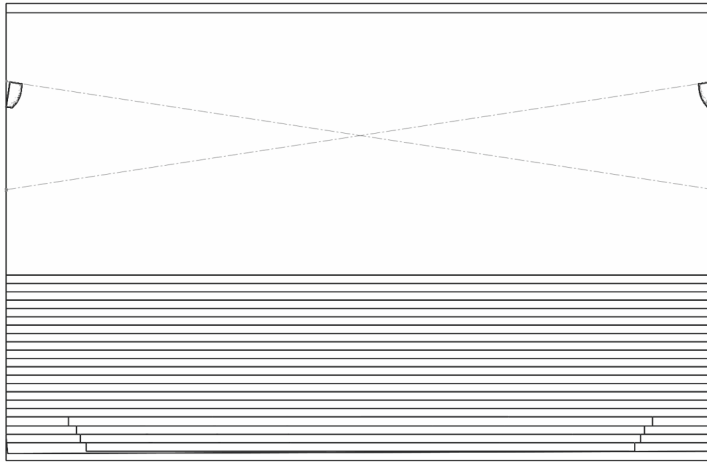

6. Lock the tilt adjustment.
7. Place the laser alignment tool in position two against the rear wall surround speakers.
8. Adjust the tilt of the rear wall surround speakers, using the two-axis wall mount brackets or recommended cables, so that the laser beam hits a target approximately 2.5 m (8 ft.) above the first row.

You may need to rotate the laser alignment tool horizontally.

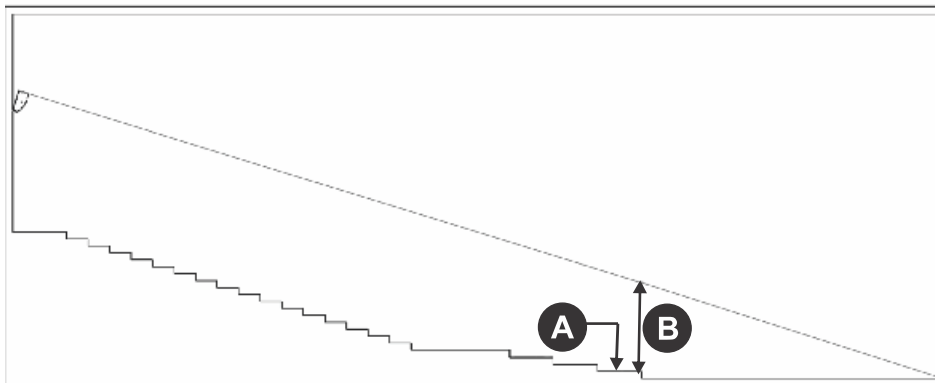

A	First row
B	2.5 m (8 ft.)

9. Lock the tilt adjustment.

Aligning the wall channel speakers (advanced method)

The advanced method aligns the speakers to the critical listening area.

The critical listening area is a rectangle surrounding the reference listening position, where the length is one-third the distance between the first and last row, and the width is one-third the room width.

1. Place the laser alignment tool in position one.

2. Adjust the pan of all the wall surround speakers, using the two-axis wall mount brackets or recommended cables, so that the laser beam hits targets set up at corresponding staggered aiming points on the center line of the critical listening area.



The number of staggered aiming points on center line of critical listening area equals the number of pairs of surround speakers located on the side walls.

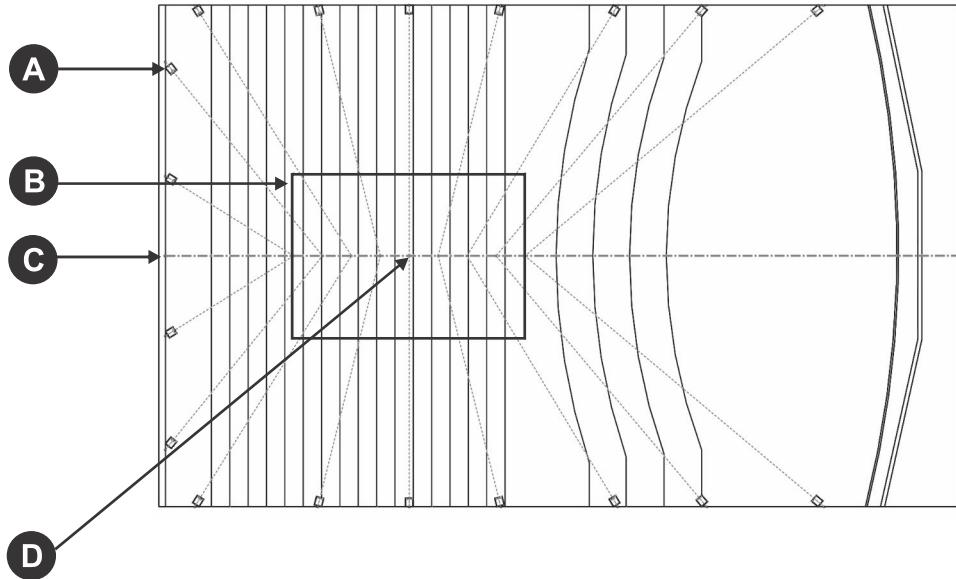

A	Wall surround speaker
B	Critical listening area
C	Center line of the critical listening area
D	Reference listening position

3. Lock the pan adjustment.
4. Place the laser alignment tool in position two against the side wall surround speakers.
5. Adjust the tilt of the side wall surround speakers, using the two-axis wall mount brackets or recommended cables, so that the laser beam hits the opposite wall approximately 2.5 m (8 ft.) above the floor.

You may need to rotate the laser alignment tool horizontally.

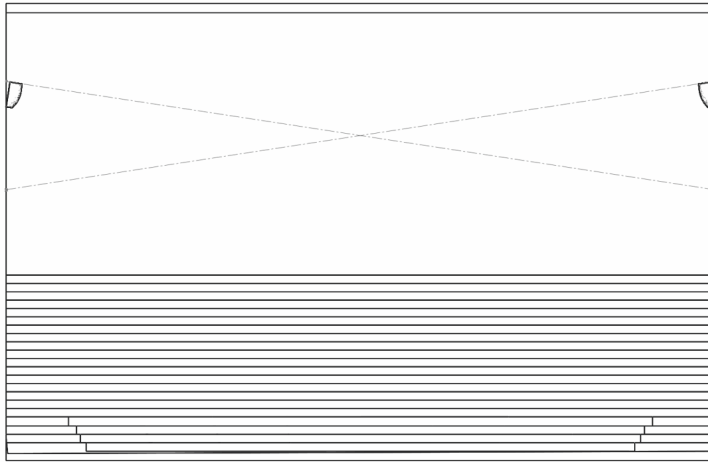

6. Lock the tilt adjustment.
7. Place the laser alignment tool in position two against the rear wall surround speakers.
8. Adjust the tilt of the rear wall surround speakers, using the two-axis wall mount brackets or recommended cables, so that the laser beam hits a target approximately 2.5 m (8 ft.) above the first row.

You may need to rotate the laser alignment tool horizontally.

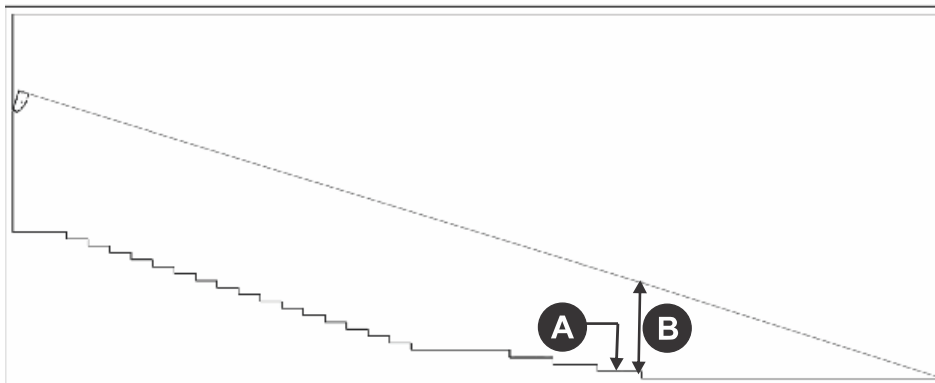

A	First row
B	2.5 m (8 ft.)

9. Lock the tilt adjustment.

Aligning the wall channel speakers (Dolby Atmos)

Use this procedure to properly align wall channel speakers set up in a Dolby Atmos configuration.

1. Place the laser alignment tool in position one.
2. Adjust the pan of all the wall surround speakers, using the two-axis wall mount brackets or recommended cables, so that the laser beam hits targets set up at the reference listening

position, or corresponding points on the edges of the critical listening area as shown on the following diagram.

For more detailed information, refer to *Dolby Atmos Specifications Version 2, sections 4.11 and 4.12.*

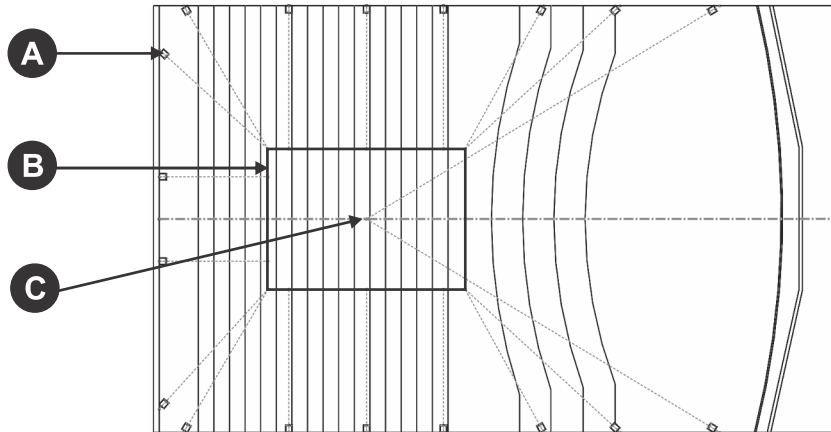

A	Wall surround speaker
B	Critical listening area
C	Reference listening position

3. Lock the pan adjustment.
4. Place the laser alignment tool in position two against the side wall surround speakers.
5. Adjust the tilt of the side wall surround speakers, using the two-axis wall mount brackets or recommended cables, so that the laser beam hits the opposite wall approximately 2.5 m (8 ft.) above the floor.

You may need to rotate the laser alignment tool horizontally.

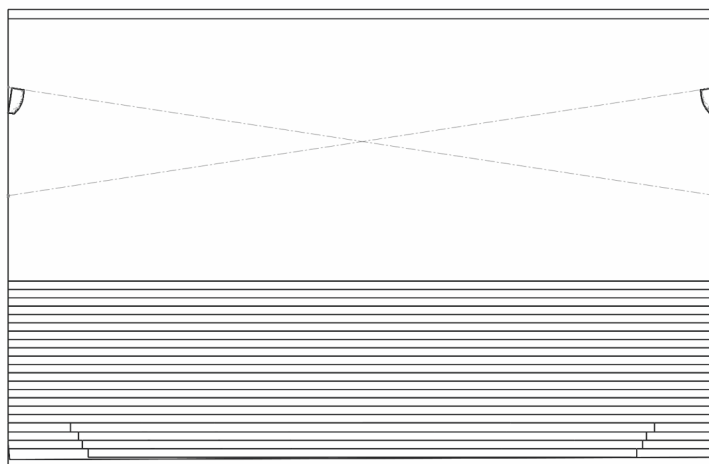

6. Lock the tilt adjustment.
7. Place the laser alignment tool in position two against the rear wall surround speakers.
8. Adjust the tilt of the rear wall surround speakers, using the two-axis wall mount brackets or recommended cables, so that the laser beam hits a target approximately 2.5 m (8 ft.) above the first row.

You may need to rotate the laser alignment tool horizontally.

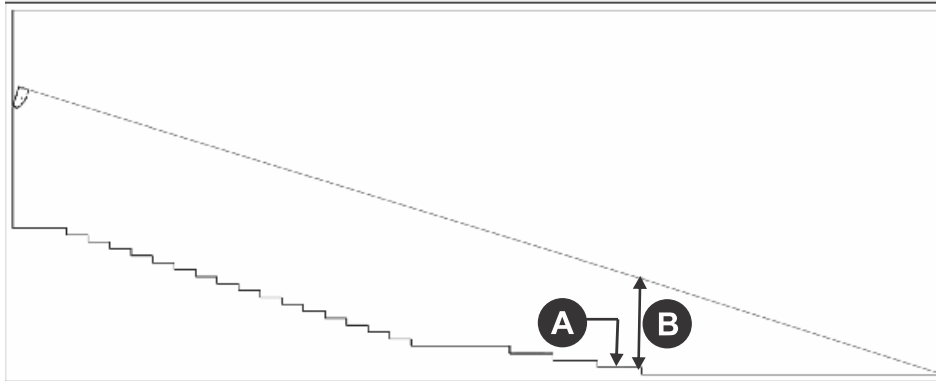

A	First row
B	2.5 m (8 ft.)

9. Lock the tilt adjustment.

Aligning the ceiling surround speakers (Dolby Atmos)

Use this procedure to properly align ceiling surround speakers set up in a Dolby Atmos configuration.

1. Place the laser alignment tool in position three.
2. Adjust the tilt of the ceiling surround speakers, except for the rear most pair, using the three-axis ceiling mount brackets or the recommended cables so that the laser beam hits the back wall, approximately 2.5 m (8 ft.) above the rear floor.
Ensure that you provide adequate coverage of the critical listening area. For more detailed information, refer to *Dolby Atmos Specifications Version 2, sections 4.11 and 4.12.*
3. Lock the tilt adjustment.
4. Place the laser alignment tool in position two against the rear most ceiling surround speakers.
5. Adjust the tilt of the rear most ceiling surround speakers, using the three-axis ceiling mount brackets or recommended cables, so that the laser beam hits a target approximately 2.5 m (8 ft.) above the first row.

You may need to rotate the laser alignment tool horizontally.

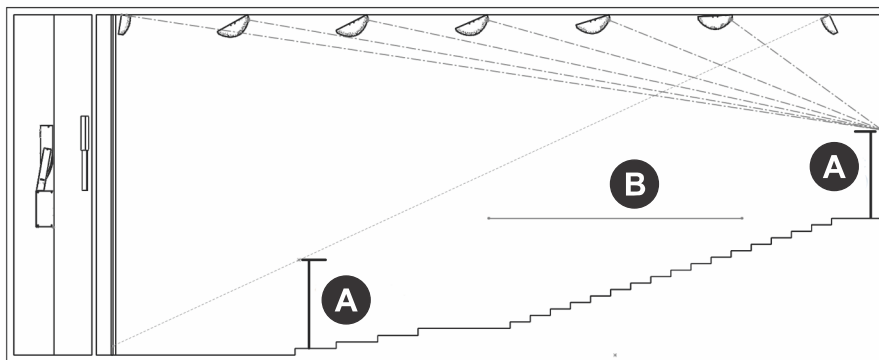

A	2.5 m (8 ft.)
B	Critical listening area

6. Lock the tilt adjustment.
7. Place the laser alignment tool in position three.
8. Adjust the pan of the ceiling surround speakers, using the using the three-axis ceiling mount brackets or recommended cables, so that the laser beam hits the center line of the room.



It is critical that all ceiling surround speakers are aimed to this center line.

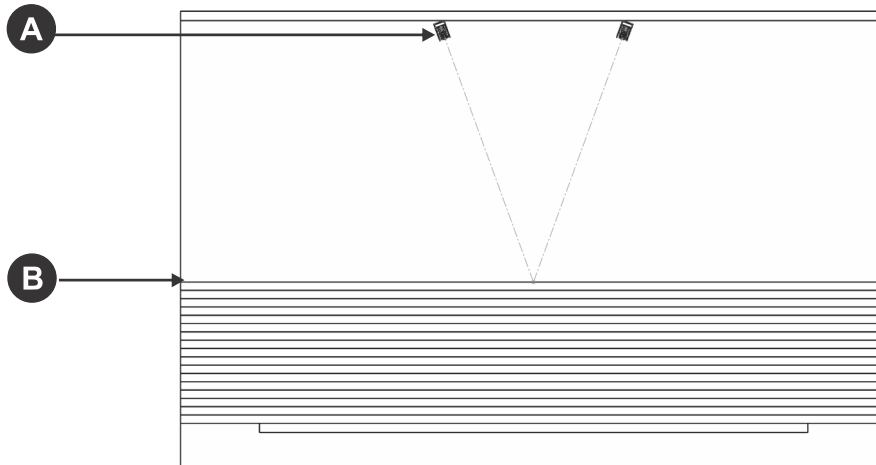

A	Ceiling surround speaker
B	Center line of the room

9. Lock the pan adjustment.
10. Adjust the roll of the ceiling surround speakers, using the using the three-axis ceiling mount brackets or cable kits, so that the speaker outside edges are parallel to each other and also parallel to side walls and ceiling tiles. You can confirm the adjustment by looking up from the floor.

Technical support

- North and South America: +1-800-221-8025 or tech-support@christiedigital.com
- Europe, Middle East, and Africa: +44 (0) 1189 778111 or techsupport-emea@christiedigital.com
- Asia Pacific: tech-asia@christiedigital.com