

MODEL 19020 SERIES

KEY FEATURES

- 10 channels in one device
- 10 sets of sync output and measurement
- ACWV/DCWV/IR 3-in-1 EST test
- Master/Slave control up to 10 units
- Programmable V-output and limits
- OSC (Open/Short Check)
- Flashover detection
- 5kVAC & 6kVDC hipot test
- 1MΩ~50GΩ insulation resistance test
- Standard RS-232/Handler/GPIB interfaces
- Large LCD panel
- Panel lock function
- CE mark

APPLICATIONS

- Power cord
- Capacitor
- Resistance
- Switch
- Connector
- Transformer
- Charger
- Adapter



MULTI-CHANNEL HIPOT TESTER MODEL 19020 SERIES

High Efficiency Hipot Test Solution

The hipot test is one of the major test items in electrical safety testing. All electrical components and products including transformers, capacitors, power supplies, chargers, and home appliances require hipot testing.

With more than 3 decades of experience in developing instruments for test and measurement, Chroma created the 19020 Multi-Channel Hipot Tester with a brand new architecture. It can measure the hipot leakage current of all channels at the same time and conduct tests on up to 100 DUTs simultaneously.

Chroma 19020 saves space on the production line by eliminating the need to purchase multiple hipot testers. Its one-time multi-channel test increases the efficiency of electrical safety testing. It improves manufacturing efficiency and reduces testing risks for products that require only hipot testing.

Chroma 19020 also has powerful functions for Flashover detection and Open/Short Check. With several international patents, it is the best tool for regulatory electrical hipot tests as it not only offers reliable quality, but also creates a highly efficient test platform.

World's First Sync Hipot Test (Patent Registered)

Chroma 19020 comes equipped with the world's first sync hipot test function. One single unit can operate 10 channels simultaneously with synchronized output and measurements. Up to 10 units (master & slave) can be linked to have 100 channels in total. These can be grouped for output as to avoid creating voltage differences caused by adjacent tests as well as to improve productivity.

Apply Chroma 19020 to various electrical products for quality assurance sampling, production line tests, and other previously time consuming testing demands.

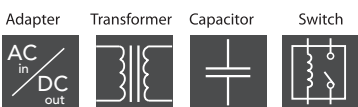

SYNCHRONOUS HI-POT TEST

One issue frequently encountered when testing multiple DUTs for hipot is that the voltage output cannot be synchronized. When planning for a production line or plant automation, facilities are often minimized and space optimized. As a result, the distance between two DUTs is usually quite small. For example, using an output voltage of 5kVac, if the output of the hipot tester is not synchronized, the two DUTs may create a discharge of high voltage difference (up to 14kV peak-peak). This can cause the fixture to be damaged and create erroneous test results. Chroma 19020 synchronizes the output signal, preventing high voltage differences on the adjacent two ends. This not only extends the life of production equipment but also can reduce the occurrence of misjudgments.

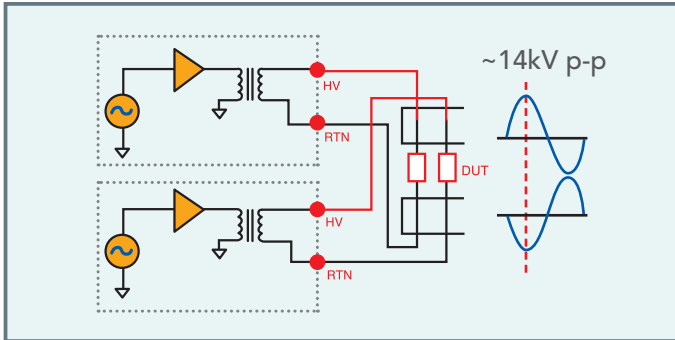

Figure 1 : Unsynchronized Output

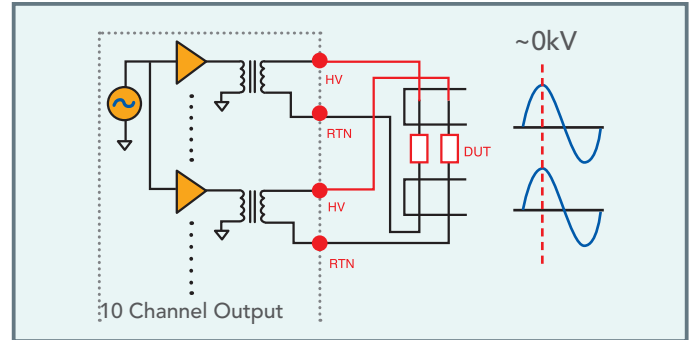

Figure 2 : Synchronized Output

FLASHOVER DETECTION

As with other Chroma EST instruments, the 19020 has a Flashover detection function. Flashover is the electrical discharge generated by a high electric field inside or on the surface of insulation material which causes the DUT to lose its insulation characteristics and form a transient or discontinuous discharge. It can cause a carbonized conductive path, or even damage the product under test. Flashover cannot be detected by only monitoring leakage current. The change rates of the test voltage or leakage current must also be monitored to identify flashover as its detection is one of the most indispensable test items for electrical safety testing.

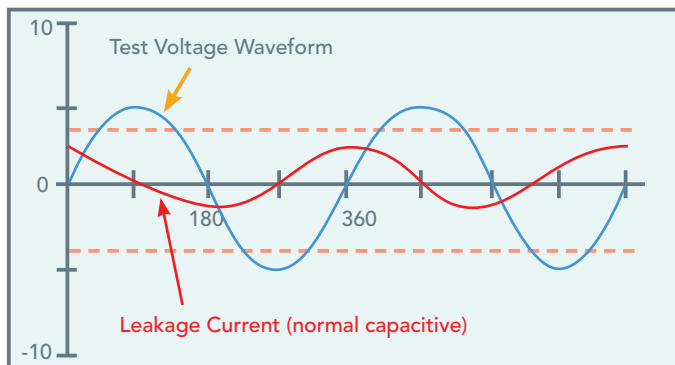

Figure 3 : Normal Leakage Current Waveform

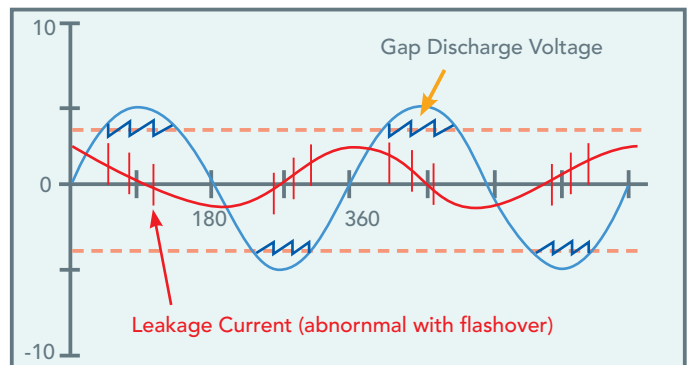

Figure 4 : Leakage Current Waveform when Flashover occurred

OPEN / SHORT CHECK (OSC)

The OSC function checks for any Open (bad connection) or Short (DUT short circuited) errors during testing. If a DUT has an open circuit during testing, the unit might be misjudged as a good product. If a DUT has a short circuit, the OSC function can filter it out early to diminish damage to the fixture and save testing costs.

In general, products under hi-pot test have capacitance (CX). CX could be tens of pF to several μ F under normal operating conditions. When the circuit connection is interrupted, a small capacitance (C_c in Figure 6) will be formed on the broken interface that is usually lower than 10pF. This makes the entire capacitance of the product lower than its normal value. The capacitance of a product may be higher than normal when the product is short-circuited or near a short circuit. Thus, the high/low limits of capacitance variation can be used to identify short circuit errors.

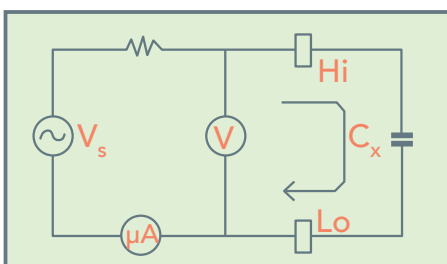

Figure 5 : Normal Connection

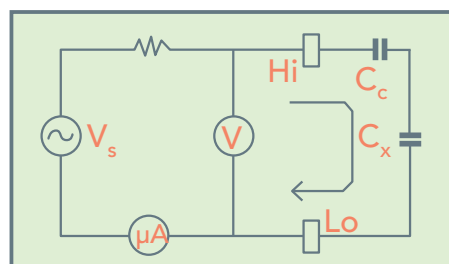

Figure 6 : Connection Open

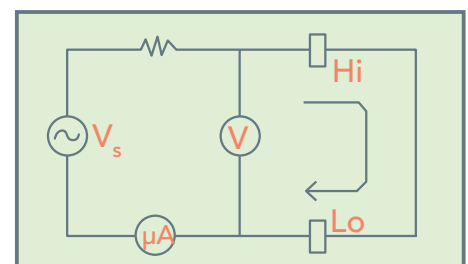

Figure 7 : Connection Short

APPLICATION

Chroma 19020 can be used to test a variety of electrical parts and products. The multi-channel hipot tester can test multiple DUTs at once. Some applications include:

- Power cord and other cable material for automation devices
- Capacitor and resistance for automation devices
- Insulation test of switch and connector
- One-time testing of transformer with multiple pins or multiple units
- Production planning for charger and adapter

Together with the 190201 3-Way Scanner, the 19020 can finish 3 hipot tests at once. Taking a two-terminal inductor as an example, the following three hipot tests can be done at one time within a DUT loading time.

1. Primary to secondary hipot test
2. Primary to core hipot test
3. Secondary to core Hipot test

This can be applied to transformer, power adapter, common mode choke and more.

Chroma has accessories and fixtures available for many test solutions. Please contact your local vendor for further information.



Figure 8 : A190201 with 3 way scanning

PANEL DESCRIPTION

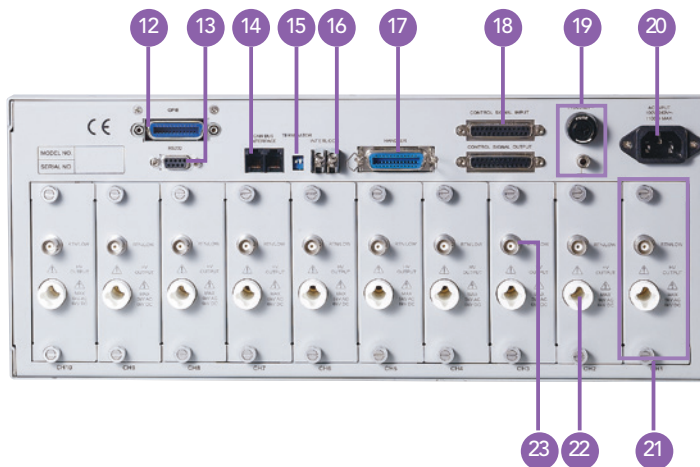
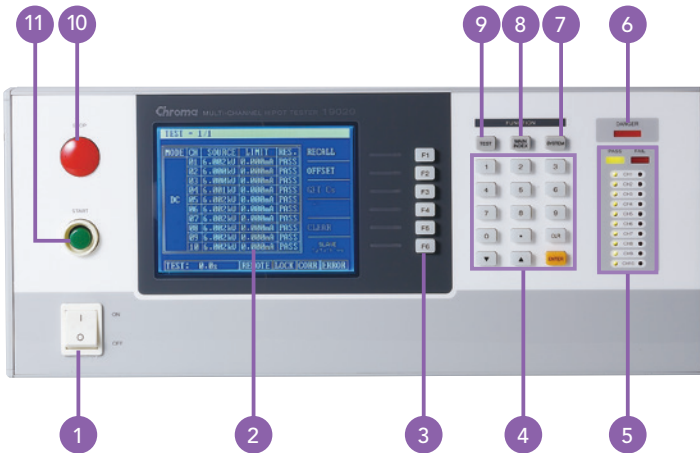

1. Power Switch
2. LCD Display
3. Function Keys
4. Cursor and Enter Keys
5. PASS/FAIL LED Indicator
6. Danger LED indicator
7. System Index Key
8. Main Function Key
9. Test Key
10. STOP Key
11. START Key
12. GPIB Interface
13. RS232 Interface
14. Internal Communication Interface
15. Master/Slave selector
16. Interlock
17. Handler Interface
18. Internal Control Interface
19. Fuse and Earth Terminal
20. AC Input
21. HV Output Module
22. High Voltage Terminal
23. Return/Low Terminal

SPECIFICATIONS

Model	19020	19021	19022	19023-8-20
Mode	ACWV/DCWV/IR/Multi-channel	ACWV/Multi-channel	DCWV/IR/Multi-channel	ACWV/Multi-channel
Withstanding Voltage Test				
Output Voltage	AC : 0.05~5kV ; DC : 0.05~6kV	AC : 0.05~6kV	DC : 0.05~8kV	AC : 0.05~8kV
Load Regulation	≤(1% of setting + 0.1% of full scale)			
Voltage Resolution	2V			
Voltage Accuracy	±(1% of setting + 0.1% of full scale)			
Cutoff Current	AC : 0.01~10mA ; DC : 0.001~5mA	AC : 0.01 ~ 8mA	DC : 0.001 ~ 3.5mA	AC : 0.01 ~ 20mA
Current Resolution	AC : 1 μA, DC : 0.1 μA			
Current Accuracy	±(1% of setting +0.5% of full scale)			
Output Frequency	50Hz / 60Hz			
Flashover Detection	AC : 1mA~20mA ; DC : 1mA~10mA			
Test Time	0.03 ~ 999.9 sec, continue			
Ramp Time	0.1 ~ 999.9 sec, off			
Fall Time	0.1 ~ 999.9 sec, off			
Dwell Time	0.1 ~ 999.9 sec, off			
Waveform	Sine wave			
Insulation Resistance Test				
Output Voltage	DC : 0.05~1kV	-	DC : 0.05~1kV	-
Voltage Resolution	2V			
Voltage Accuracy	±(2% of setting + 0.5% of full range)			
IR Range	1MΩ ~ 50GΩ			
Resistance Accuracy	≥500V	1MΩ~1GΩ : ± 3% of reading + 0.1% of full range 1GΩ~10GΩ : ± 7% of reading + 0.2% of full range 10GΩ~50GΩ : ± 10% of reading + 1% of full range		
	<500V	1MΩ~1GΩ : ± 3% of reading + (0.2*500/Vs)% of full scale		
Test Time	0.3~999.9 sec, continue			
Memory Storage				
Save/Recall	30 instrument setups with up to 10 test steps can be stored into and recalled from the internal memory			
Secure Protection Function				
Fast Output Cut-off	0.4ms after NG happen			
Panel Operation Lock	Present password			
Interlock	YES			
GO/NG Judgment Window				
Indication, Alarm	GO : Short sound, Green LED ; NG : Long sound, Red LED			
Data Hold	Least tests data memories			
Memory Storage	30 instrument setups with up to 10 test steps			
Interface				
RS-232, Handler & GPIB				
CANBus & data control interface are used for max. 10 units of master & slaves connection				
General				
Operation Environment	Temperature : 0°C ~ 45°C ; Humidity : 15%~95% RH @ ≤40°C and no condensation			
Power Consumption	Standby : < 250W ; With rated load : <1000W			
Power Requirements	90~264Vac ; 47~63Hz			
Dimension (HxWxD)	174 x 428 x 600 mm / 6.85 x16.85 x 23.62 inch			
Weight	Approx.40 kg/88.18lbs			

All specifications are subject to change without notice.

ORDERING INFORMATION

19020 : Multi-Channel Hipot Tester (ACWV/DCWV/IR)
 19020-4 : Multi-Channel Hipot Tester (ACWV/DCWV/IR/4CH)
 19021 : Multi-Channel Hipot Tester (ACWV)
 19021-4 : Multi-Channel Hipot Tester (ACWV/4CH)
 19022 : Multi-Channel Hipot Tester (DCWV/IR)
 19022-4 : Multi-Channel Hipot Tester (DCWV/IR/4CH)
 19023-8-20 : Multi-Channel Hipot Tester(8kVAC/4CH)
 A190200 : 19" Rack Mounting Kit for 19020 Series
 A190201 : 3-way Scanner Box (10CH)
 A190202 : 3-way Scanner Box (4CH)
 A190203 : 19020 Series Hipot Tester software

* HV cable is optional for customized requirement

Get more product & global distributor information in Chroma ATE APP



iOS



Android

Search Keyword

19020

HEADQUARTERS
 CHROMA ATE INC.
 66 Huaya 1st Road,
 Guishan, Taoyuan
 33383, Taiwan
 T +886-3-327-9999
 F +886-3-327-8898
 www.chromaate.com
 info@chromaate.com

U.S.A.
 CHROMA SYSTEMS
 SOLUTIONS, INC.
 19772 Pauling,
 Foothill Ranch,
 CA 92610
 T +1-949-600-6400
 F +1-949-600-6401
 www.chromausa.com
 sales@chromausa.com

EUROPE
 CHROMA ATE EUROPE B.V.
 Morsestraat 32,
 6716 AH Ede,
 The Netherlands
 T +31-318-648282
 F +31-318-648288
 www.chroma.eu.com
 salesnl@chroma.eu.com

CHROMA GERMANY GMBH
 Südtiroler Str. 9, 86165,
 Augsburg, Germany
 T +49-821-790967-0
 F +49-821-790967-600
 www.chroma.eu.com
 salesde@chroma.eu.com

JAPAN
 CHROMA JAPAN
 CORP.
 888 Nippa-cho,
 Kouhoku-ku,
 Yokohama-shi,
 Kanagawa,
 223-0057 Japan
 T +81-45-542-1118
 F +81-45-542-1080
 www.chroma.co.jp
 info@chroma.co.jp

KOREA
 CHROMA ATE
 KOREA BRANCH
 3F Richtogether
 Center, 14,
 Pangyoyeok-ro 192,
 Bundang-gu,
 Seongnam-si,
 Gyeonggi-do
 13524, Korea
 T +82-31-781-1025
 F +82-31-8017-6614
 www.chromaate.co.kr
 info@chromaate.com

CHINA
 CHROMA ELECTRONICS
 (SHENZHEN) CO., LTD.
 8F, No.4, Nanyou Tian
 An Industrial Estate,
 Shenzhen, China
 T +86-755-2664-4598
 F +86-755-2641-9620
 www.chroma.com.cn
 info@chromaate.com

SOUTHEAST ASIA
 QUANTEL PTE LTD.
 (A company of Chroma Group)
 25 Kallang Avenue #05-02
 Singapore 339416
 T +65-6745-3200
 F +65-6745-9764
 www.quantel-global.com
 sales@quantel-global.com