



Touchboards

205 Westwood Ave, Long Branch, NJ 07740
Phone: 866-94 BOARDS (26273) / (732)-222-1511
Fax: (732)-222-7088 | E-mail: sales@touchboards.com

10 11 00/CLC
BuyLine 3119
Catalog No. 109



PRODUCT CATALOG

Claridge MAIN OFFICE
AND PRODUCTION FACILITY
601 Highway 62-65 South
P.O. Box 910
Harrison, Arkansas
Zip 72602-0910
Phone: 870-743-2200
Toll Free: 800-434-4610
Fax: 870-743-1908
claridge@claridgeproducts.com

CLARIDGE LOS ANGELES
Manufacturing & Distribution
1477 Davril Circle
Corona, California
Zip 92880-6957
Phone: 951-734-6262
Fax: 951-734-6464
claridge@claridgewest.com

EASTERN DIVISION
Sales and Warehouse
500 Ogden Avenue
P.O. Box 189
Mamaroneck, New York
Zip 10543-0189
Phone: 914-381-5330
Fax: 914-381-2145
east@claridgeproducts.com

MIDWEST DIVISION
Sales and Warehouse
713 South Vermont Street
Palatine, Illinois
Zip 60067-7138
Phone: 847-991-8822
Fax: 847-991-9057
mw@claridgeproducts.com

SOUTH CENTRAL DIVISION
Sales and Warehouse
3248 Towerwood Drive
Farmers Branch, Texas
Zip 75234-2315
Phone: 972-247-8075
Fax: 972-484-8149
sc@claridgeproducts.com

WESTERN DIVISION
Sales and Warehouse
14736 Wicks Boulevard
San Leandro, California
Zip 94577-6770
Phone: 510-351-8183
Fax: 510-351-8241
west@claridgeproducts.com

Factory Built Units

SERIES 1, 3, 4, 5, 8, and 185

Series 1

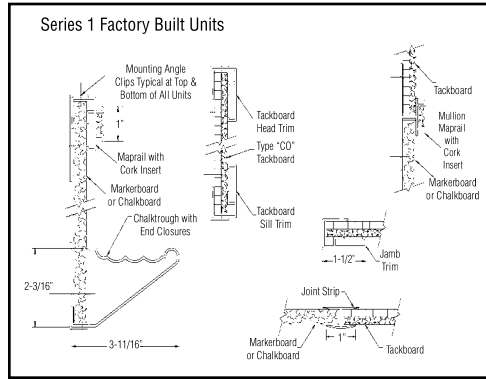

SERIES 1

- Perimeter trim is 1 1/2" wide.
- Furnished with angle clip hangers 2' on center, top and bottom.

Series 3 Factory Built Units

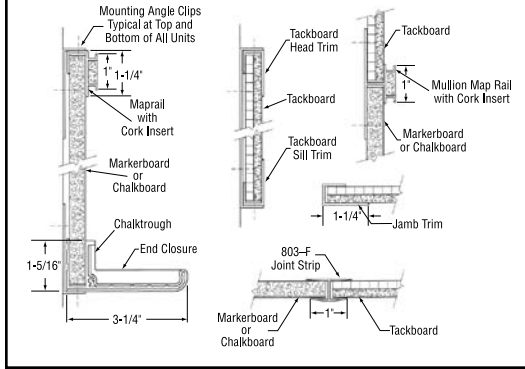

SERIES 3

- Perimeter trim is 1 1/4" wide.
- Furnished with angle clip hangers 2' on center, top and bottom.

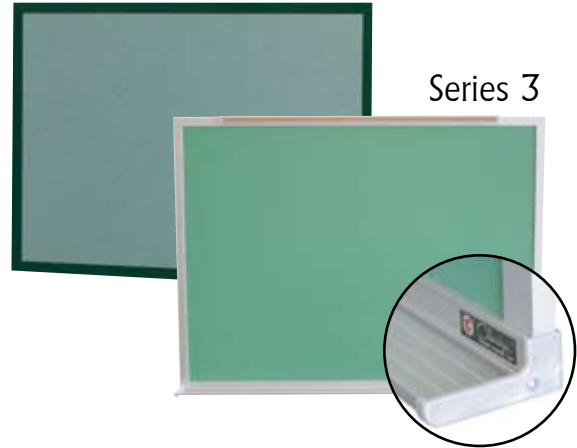

Series 3

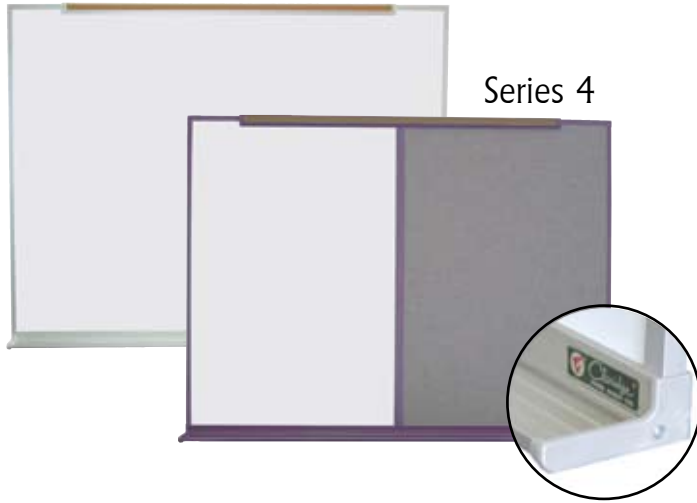

Series 4

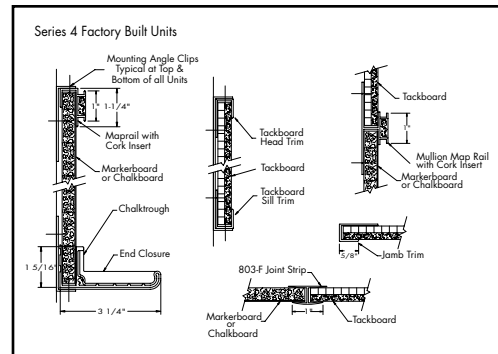

SERIES 4

- Perimeter trim is 5/8" wide.
- Furnished with clip angle hangers 2' on center, top and bottom.

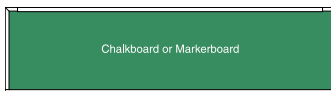

Type A



Type CO

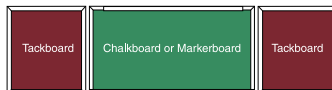

Type C

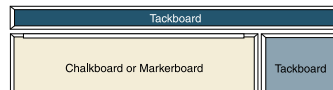

Type ER (Tackboard on Right) — Type EL (Tackboard on Left)

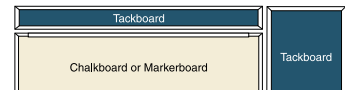

Type GR (Tackboard on Right) — Type GL (Tackboard on Left)

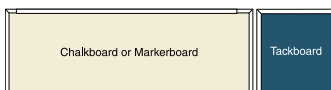

Type BR (Tackboard on Right) — Type BL (Tackboard on Left)

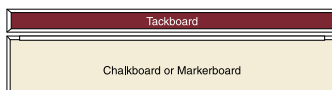

Type D



Type F

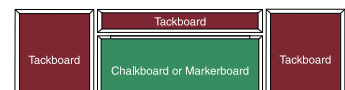

Type H

Typical Markerboard, Chalkboard & Tackboard Arrangements



Series 5

Factory Built Units

Features:

- Porcelain enamel steel LCS markerboards and Vitracite chalkboards
- Claridge Cork, Fabricork, Designer Fabric, Hook-Fab, and Tan Nucork Tackboards
- Satin anodize aluminum frame
- Maximum length, 16'0"; maximum height - Type A and Type CO units - 4'0"
- O.A. panel thickness approx. 1/2"

Options:

- Color anodize or powder coat finish aluminum frames
- Radius corners available, Series 4 units

Finished size of units is 1/4" larger in height and width than sizes listed. If exact overall size is required, specify when ordering.

Installation using 16A adhesive is recommended. Screws or wall anchors are not included.

Freight class 70.

Visit www.claridgeproducts.com for CAD library and specifications.

SERIES 5

- Perimeter trim is 5/8" wide.
- Furnished with steel mounting clips at top and angle clips at bottom, 2' on center.

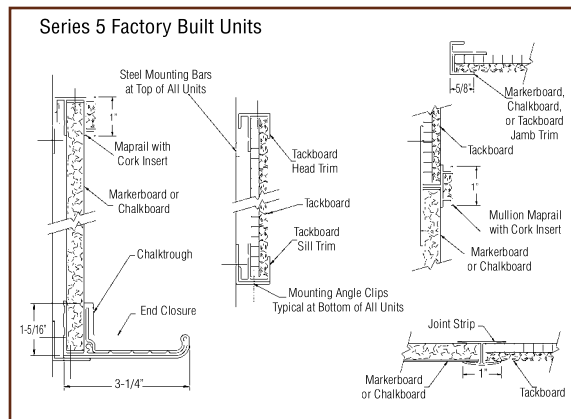

SERIES 8

- Perimeter trim is 5/16" wide.
- Furnished with clip angle hangers 2' on center, top and bottom.

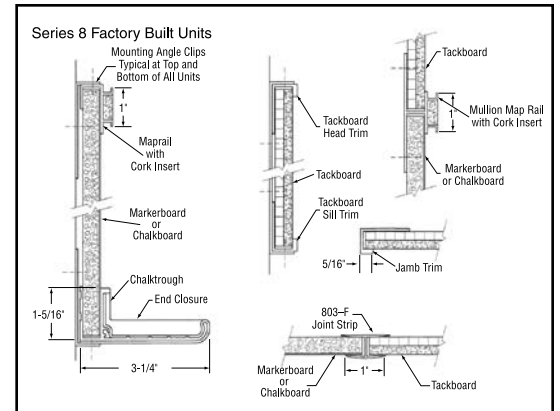
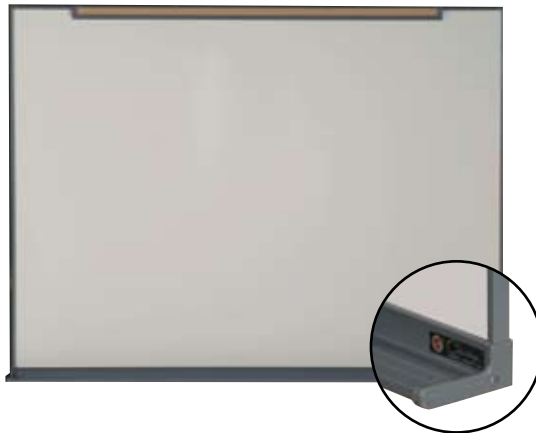

Series 185

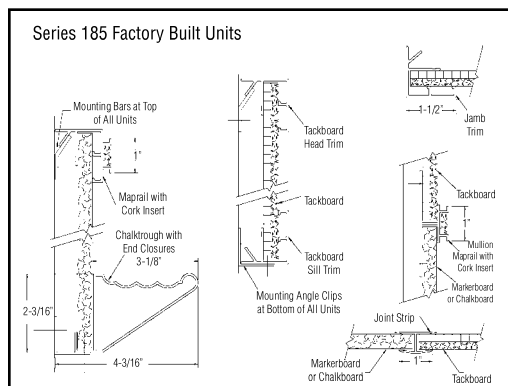

SERIES 185

- Perimeter trim is 1-1/2" wide.
- Furnished with Z-bar clips for top and angle clips for bottom, 2' on center.

Note: Necessary 12" square, 1/2" Duracore blocking pads are furnished.

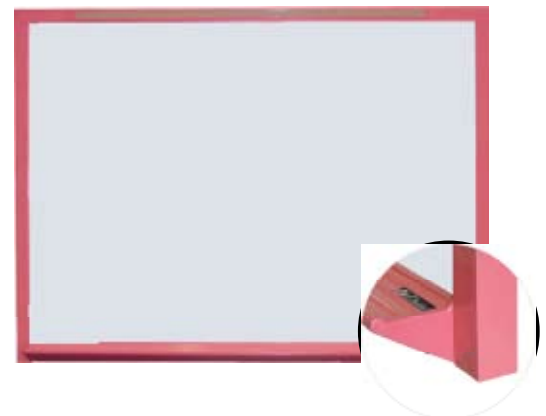

S873 Markerboard and Visual Communication System

Claridge LCS-II low gloss porcelain writing surface combines with 3M's SCP712 Super Close Projector and digital annotation sensor to provide an ideal solution for memorable presentations.

- LCS-II with low-gloss surface for easy writing, clean erasing, and crisp projection; notched aluminum frame for cord management
- Projector mounts above the board virtually eliminating all shadows for interactive markerboard use
- Super Close Projector has single button operation; wall mounting provides for the unit to be positioned and ready to use at a moment's notice



Easy to use, simple to install.

LCS-II Markerboards

- Premium writing surface in either #92 White or #75 Low Gloss, both with a smooth surface for easy writing and clean erasing
- Minimal "hot spot" (#75 Low Gloss can be used as a projection surface)
- Made from enameling grade steel during a 3-coat process
- After pre-cleaning a ground (primer) coat of porcelain is applied to front and back of steel; color cover (finish) coat is applied to face of steel and is fusion bonded to the steel substrate

Claridge now offers *three* porcelain enamel writing surfaces:

- LCS-II markerboard dry-erase writing surface in #92 White or #75 Low Gloss
- LCS markerboard dry-erase writing surface for face sheets and skins
- Vitracite chalkboard writing surface

Vitracite® Chalkboard and LCS® Markerboard Steel Skins

(Made from aluminized steel sheets)

The most practical and economical way to rejuvenate old chalkboards is to install steel skins (face sheets) over existing old, badly-worn chalkboards. Steel skins can be applied on the face of natural slate, composition chalkboard, or slated plaster walls. Converts old defective boards into permanent new markerboards or chalkboards of superior quality which will provide many years of service. Sheets are shipped precut to customer's specifications. Skins can be installed by qualified installer using 16A Adhesive, commercial adhesive, or double-sided tape, in accordance with local building codes.

INTRODUCING LCS EZ STICK SKINS

Designed to make resurfacing existing boards a breeze, EZ Stick Skins are LCS Skins (face sheets) backed with double-sided tape. EZ Stick Skin installations use no solvents, eliminate drying time and are always a consistent thickness. Measure to verify fit, clean old board surface, position new skin, peel and stick - its that easy.



INTRODUCING EZ FIT PANELS

Designed to fit over existing boards, EZ Fit panels are LCS-II in either #92 White or #75 Low Gloss. Porcelain writing surface is mounted on hardboard with moisture barrier back. Panels have 1/2" face satin anodize aluminum frame. Holes are pre-drilled 2" on center; 1" countersink screws included.



L2EBS3 - LCS-II and eBeam System 3 Complete

The world's smallest interactive markerboard solution AND an LCS-II porcelain enamel steel markerboard with a low gloss ideal for writing, erasing and projecting - all at the same time.

- eBeam receiver is permanently attached to the face of the markerboard
- eBeam Complete software and all accessories included
- Satin anodized aluminum frame with 3/8" face provides cord management through a deep, notched design
- Z-bar hangers for easy installation.



LCS-II-217-M No. 75 LCS-II Low-Gloss White Markerboard

Face Sheet
MDF Core
Moisture Barrier Backing

LCS Porcelain Enamel
Steel Markerboard Skins –
2 colors

Vitracite Porcelain
Enamel Steel
Chalkboard Skins –
3 colors

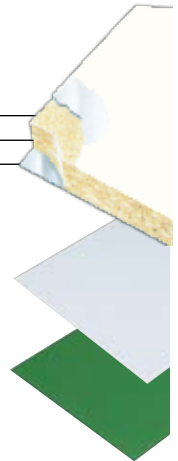

Markerboard and Chalkboard Colors

LCS-II • LCS • Vitracite

LCS-II (use with LCS markers)



No. 75 LOW GLOSS
WHITE

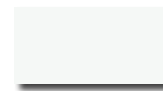

No. 92 LCS-II
WHITE

LCS - for skins or face sheets only
(use with LCS markers)

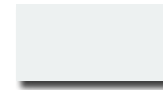

No. 32 LCS
WHITE



No. 41 LCS
LIGHT GRAY

Vitracite (use with chalk)



No. 19 Clearcite
GREEN



No. 13
BLACK



No. 16
CHARCOAL GRAY

Claridge Cork Bulletin Board

- Environmentally friendly, burlap backed cork
- Pure natural ingredients
- Smooth, durable suede-like surface
- Self-healing, soil resistant
- Tacks insert easily, gripped firmly

1/4" Unmounted
Claridge Cork



1/4" Mounted
Claridge Cork



10 11 00/CLC
BuyLine 3119



1105 Desert Sand



1100 Tan



1107 Denim



1111 Smoke



1110 Fawn

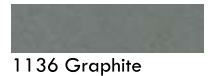

1136 Graphite



1133 Green



1113 Steel Gray



1134 Midnight



1132 Black



1135 Brick



1109 Buff

Fabricork Bulletin Boards

- Wear almost indefinitely
- Entirely washable; spots and soil wash away with household soap and water
- Vinyl fabric meets or exceeds Federal Specification CCC-W-408A

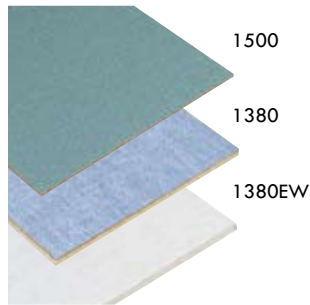

B220 Antique White



B221 Beige



C620 Dover



C621 Opal

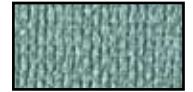

C622 Jade Mist



C623 Slate Gray



F223 Frost



F559 Dawn Blue



F560 Dusk Blue



F571 Champagne

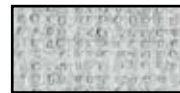

F573 Pearl Gray

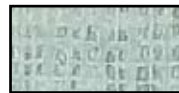

F577 Mist Green

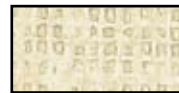

F578 Off White

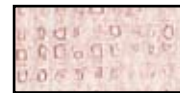

F580 Blush



F581 Academy Gray

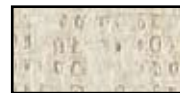

F592 Cream



F593 Mauve



F595 Slate Green



T421 White



T422 Natural

Premium Vinyl Selection



S634 Moonlit



S635 Tobacco



S636 Cranberry



S637 Smokescreen



S638 Spice



S639 Haze

Designer Fabric Bulletin Boards

- Soil and stain resistant
- 100% polyester
- Designer Fabrics have ASTM-E 84 Flame Tunnel Test Class "A" rating

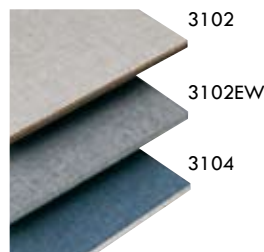

1689 Wedgewood



1694 Blue Topaz



1695 Amethyst



1691 Quartz



1699 Quarry



1698 Pearl



1690 Gray Mix



1697 Mulberry



1696 Thistle



1684 Noir



1692 Wheat



1688 Seafoam

Premium Designer Fabric Selection



1676 Green Apple



1677 Geranium



1678 Straw



1679 Lapis



1680 Angora



1681 Fossil

Hook-Fab Bulletin Boards

- Lightweight and pliable, yet durable
- Soil and stain resistant
- Use with hooktape or thumbtack

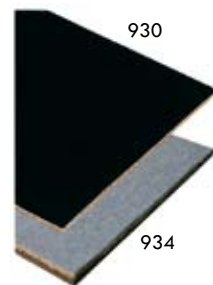

970 Lime



971 Chili Red



972 Sand



973 Silver



974 Dark Blue



975 Lightsout

Tan Nucork Bulletin Board

- Pure grain natural cork without burlap backing
- Smooth, resilient surface
- Punctures heal quickly
- Tacks insert easily, gripped firmly
- Meets Military Spec MIL-C-15116, Type II



Snap-On Aluminum Trim Detail

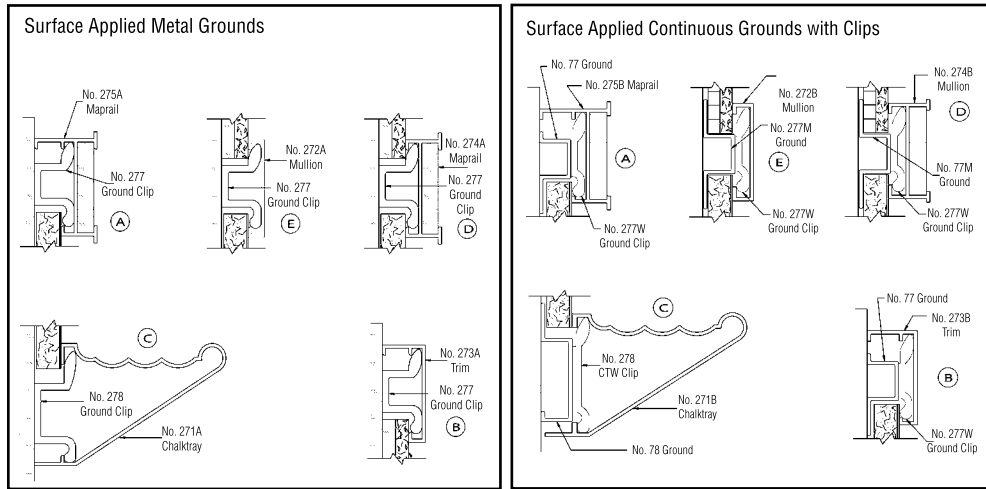

The most versatile of the field assembled trims, snap-on trim, with its wide face and no visible fasteners, adjusts to job conditions and joins in a neat, precision fit.

Trim Selection Elevation

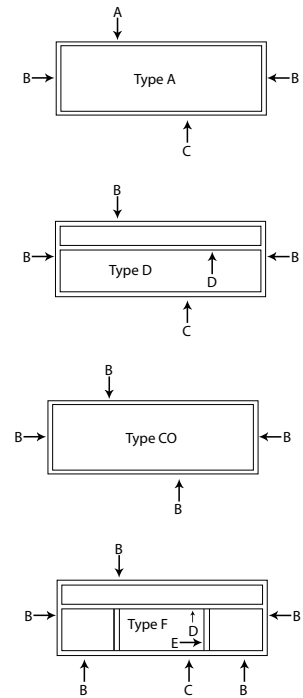

Screw-On Aluminum Trim Detail

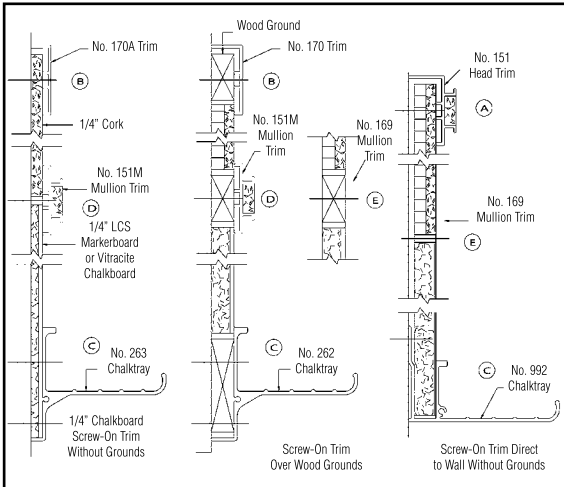

Screw-on aluminum trim, with exposed fasteners, is noted for ease of installation.

Snap-On, Screw-On, and Slip-On aluminum trim is typically furnished in stock lengths to be cut to size and applied in the field.

Slip-On Aluminum Trim Detail

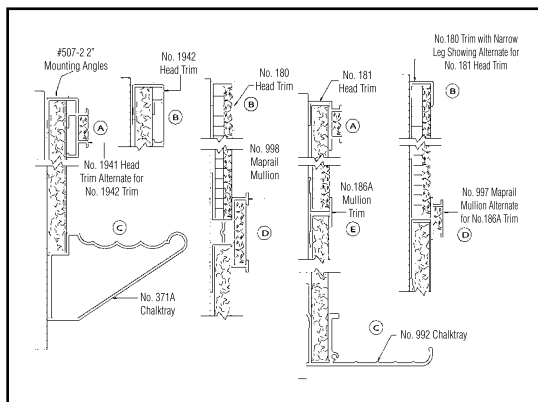

The narrow face of slip-on trim gives it a clean, low-profile appearance.

Divider Bars, Channel Trim & Angle Trim

Divider Bars

Number	Opening	Face	Stock Lengths
803	1/4"	1/2"	10'6" and 12'0"
803A	1/2"	1/2"	10'6" and 12'0"
803F	1/2"	1"	10'6" and 12'0"
12314	7/16"	1"	10'6" and 12'0"

Divider bars weigh approximately 1/4 lb. per lin. ft. Shipped by motor freight. Use freight class 85.

Channel Trim

Number	Opening	Face	Stock Lengths
804	1/4"	1/2"	8'0" and 12'0"
804A	1/2"	5/8"	8'6", 10'6", 12'6", 17'0" and 21'0"

Channel trim weighs approximately 1/4 lb. per lin. ft. 8'0" and 8'6" lengths can ship UPS or Fed Ex Ground. Balance of lengths will be shipped motor freight. Use freight class 85.

Angle Trim

Number	Description	Stock Lengths
160	1" x 1" x 1/16" angle trim	12'6"
161	1" x 1/2" x 1/16" angle trim	12'6"
162	1" x 1" x 1/8" angle trim	12'6"

No. 160 and No. 161 angle trim weighs approx. 1/4 lb. per lin. ft. No. 162 weighs 1/3 lb. Angle trim is shipped by motor freight. Use freight class 85.

Marker Walls

LCS Porcelain Enamel Steel Skins with matched butt joints are ideal for most wall conditions.

- Cover an entire wall, floor-to-ceiling
- Utilize all available space
- Panels butt together for a continuous writing surface

When laminated panels are required, LCS, mounted on 7/16" MDF, has matched butt joints and can be joined with steel spline joints for smooth alignment. For a more finished look use No. 1016 perimeter trim.



Marker Wall Detail

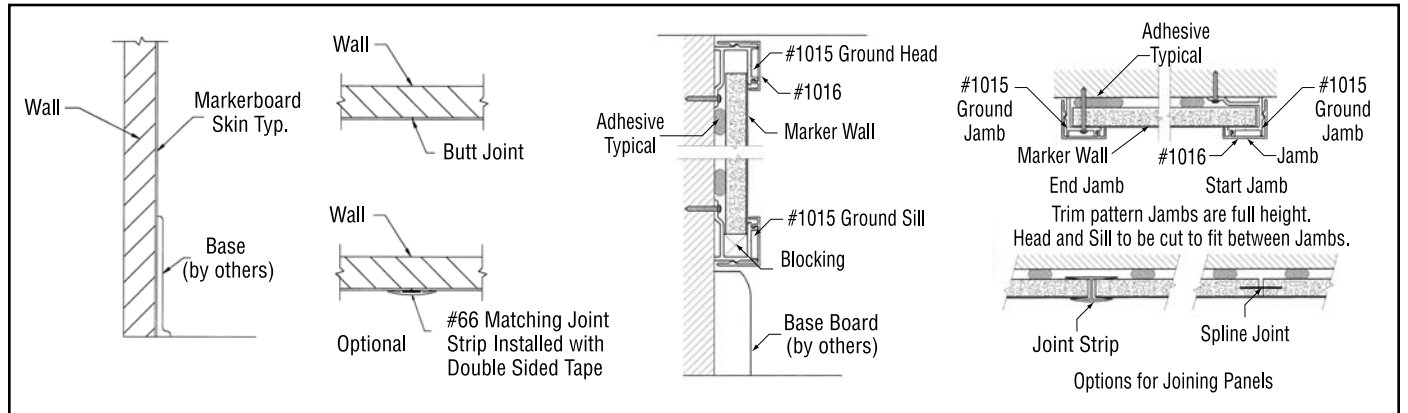

Tack Walls

Edge-wrapped panels of either Fabricork or Designer Fabric butt together to cover an entire wall or work space, floor-to-ceiling.

- Choose from Fabricork and Designer Fabric colors
- Ideal for offices, board rooms, conference rooms, etc.
- Edge-wrapped panels can be custom-made to fit existing walls

Where trim is required, fabric covered H-bars, fabric covered trim and fabric covered inside and outside corners are also available.

Tack Wall Detail

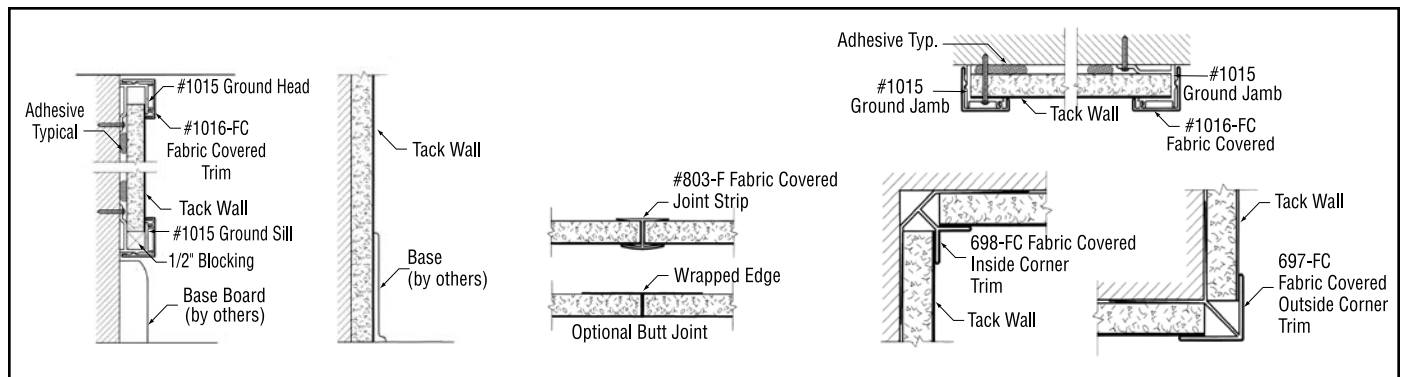



Horizontal Sliding Units

- Manually or Motor Operated Sliding Units
- Fixed back panel with 2, 3 or 4 sliding panels on 2, 3 or 4 tracks
- Sliding panels are top-suspended and glide easily over aluminum track on molded nylon rollers
- Nylon ball bearing rollers at top of unit and nylon guide rollers at bottom eliminate vibration and provide smooth, quiet operation
- Sliding panels and back panel can be: LCS markerboard; Vitracite chalkboard; or Claridge Cork, Fabricork, Designer Fabric, Hook-Fab or Tan Nucork bulletin board; Matte white or glass beaded projection screen; or COM fabrics
- Trim and panel edging are extruded aluminum with satin anodize finish (Powder coat and color anodize finish optional)
- Component parts (sliding panels with track, guide channel, hardware - no housing) available

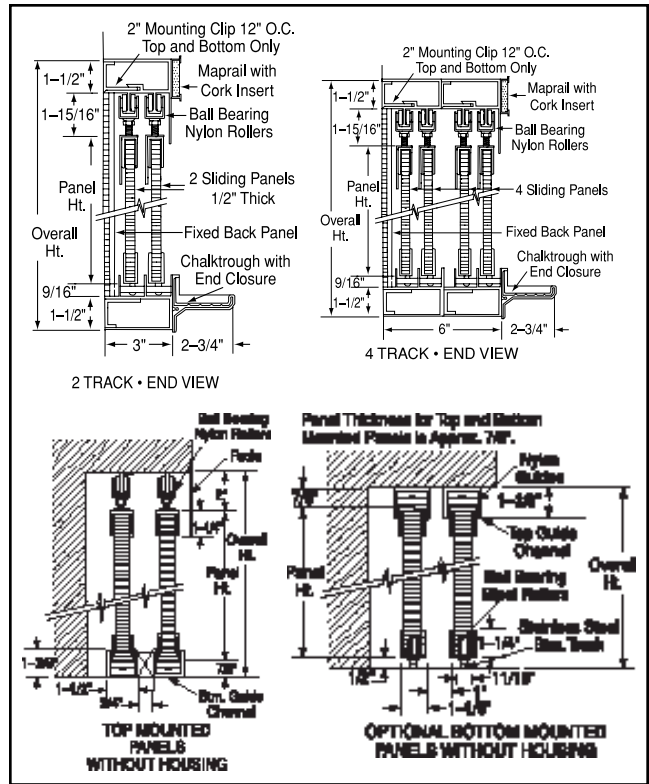

Horizontal Sliding Units

Number	Size (H x W)	Number	Size (H x W)
HS46	4' x 6'	HS414	4' x 14'
HS48	4' x 8'	HS416	4' x 16'
HS410	4' x 10'	HS420	4' x 20'
HS412	4' x 12'	HS424	4' x 24'



Vertical Sliding Units

- Manually or Motor Operated Sliding Units
- Floor and wall mounted (panels on wall mounted units slide from sill or tray to top of unit; panels on floor mounted units slide from floor to top of unit)
- One, two or three 7/8" thick sliding panels (2-panel housing is 6-1/2" deep; face is 4")
- Balanced, lightweight panel construction guards against warpage; provides needed rigidity and eliminates to and fro movement when panels are in use.
- Sliding panels and back panel can be: LCS markerboard; Vitracite chalkboard; or Claridge Cork, Fabricork, Designer Fabric, Hook-Fab or Tan Nucork bulletin board; Matte white or glass beaded projection screen; or COM fabrics
- Trim and panel edging are extruded aluminum with satin anodize finish (Powder coat and color anodize optional)

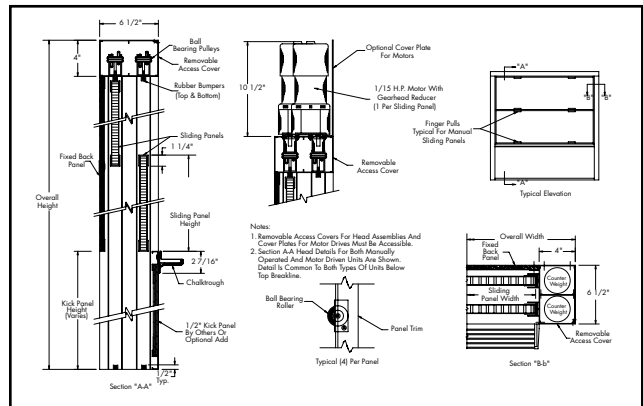

Vertical Sliding Units

Manually Operated

Floor Mounted		Wall Mounted		Motor Operated	
Number	High-Long	Number	High-Long	Number	High-Long
410CS	10' x 4'	48CSW	8' x 4'	410MO	10' x 4'
510CS	10' x 5'	58CSW	8' x 5'	510MO	10' x 5'
610CS	10' x 6'	68CSW	8' x 6'	610MO	10' x 6'
810CS	10' x 8'	88CSW	8' x 8'	810MO	10' x 8'
1010CS	10' x 10'	108CSW	8' x 10'	1010MO	10' x 10'
1210CS	10' x 12'	128CSW	8' x 12'	1210MO	10' x 12'
1410CS	10' x 14'	148CSW	8' x 14'	1410MO	10' x 14'
1610CS	10' x 16'	168CSW	8' x 16'	1610MO	10' x 16'

Optional Kick Panel and optional Wireless remote control. Approved shop drawings required. Freight class 70.

Contemporary Series Bulletin Board Cabinet

Features:

- 1-1/2" x 3" rectangular aluminum perimeter trim, satin anodize finish; inside depth 1-3/4"
- Tackable back panels can be Claridge cork, Fabricork, Designer Fabric, Hook-Fab or Tan Nucork (grooved directory back panels optional)
- 3/16" tempered glass doors with flat key tumbler locks
- Hinged door cabinets have continuous piano hinges; sliding door units, ground-in finger pulls
- Surface mounted units equipped with Z-bar hangers
- Available with header panel



2041 Contemporary Cabinet

Contemporary Cabinets

Number	Size (H x W)	Weight Lbs.
2035	3' x 2'	36
2041	3' x 4'	72
2040	4' x 4'	96
2044	4' x 6'	144
2046	4' x 8'	256
2048	4' x 10'	320
2050	4' x 12'	384

Intermediate sizes available.

Options:

- Fluorescent lights
- Weatherproofing (hinged door only)
- Recessed installation
- Medium or dark bronze anodize or powder coat finish



Note: 3'x2' cabinet has one door; 3'x4' through 4'x6' have two; and 4'x8' through 4'x12' have three.

Weatherproofed Contemporary Cabinet

Contemporary Detail

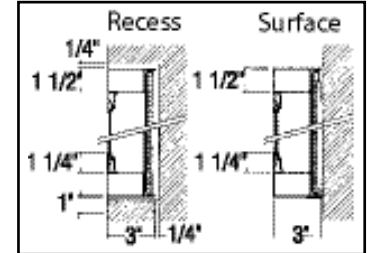

Large Door Contemporary Detail

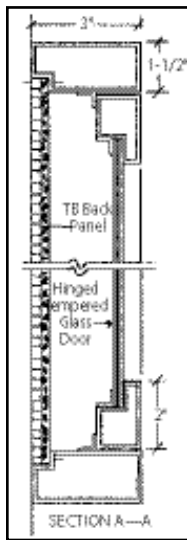

Large Contemporary Series Bulletin Board Cabinet

Features:

- Heavy-gauge rectangular aluminum, satin anodize finish
- Tempered glass doors hung on piano hinges, flat key tumbler locks
- Mitered corners reinforced for rigidity
- Tackable back panels in Claridge Cork, Fabricork, Hook-Fab, Designer Fabric or Tan Nucork
- Angle hangers furnished - top and bottom
- 3" housing - 1-3/4" I.D.; 4" - 2-3/4" I.D.

Options:

- 1-1/2" x 3" or 1-3/4" x 4" housing
- Surface or Recess installation
- Fluorescent light (4" cabinets only)
- Med. or Dk. Bronze Anodize; Powder Coat Finish

Large Contemporary Series

Number	Size (H x W)	Weight Lbs.
2153	5' x 3'	180
2156	5' x 6'	300
2164	6' x 4'	250
2168	6' x 8'	500

Note: 3' and 4' widths have one door; 6' and 8' cabinets have two.

Specify depth - 3" or 4", recess or surface installation (if recess installation, provide finished opening measurements), and type and color for back panel.



Imperial Series Bulletin and Directory Board Cabinet

Features:

- Heavy-gauge satin anodize aluminum; Z-bar hangers
- 3/16" tempered sliding glass doors; tumbler lock
- Claridge Cork, Fabricork, Designer Fabric, Hook-Fab and Tan Nucork tackable panels; Felt or Vinyl directory panels
- 3-1/4" O.A.; inside depth is 1-1/2"
- 6" Translucent plexiglas header panel



Imperial Series

Header Number	With Header	Without Header	Size (H x W)	Weight Lbs.
300	294	294	36" x 48"	80
302	296	296	36" x 72"	120
303	297	297	48" x 60"	135
304	298	298	48" x 72"	160

Options:

- Medium or Dark Bronze anodize, or Powder Coat finish
- Fluorescent light

No. 310 Bulletin Board Cabinet

Features:

- Quality construction; neatly mitered corners
- Natural, Medium or Dark Oak; Walnut, Mahogany, Cherry, and Maple, optional
- Claridge Cork, Fabricork, Designer Fabric or Hook-Fab (Grooved felt and vinyl directory panels optional)
- 3-1/4" perimeter; inside depth is 1-1/4"
- Sliding glass door shoe, channel and track are heavy-gauge extruded aluminum, bronze finish
- Z-bar hangers
- Fluorescent lights are optional



Bulletin Board Number	Size (H x W)	Weight Lbs.
310	36" x 48"	78
310A	36" x 60"	98
310B	36" x 72"	118
310C	48" x 60"	130
310D	48" x 72"	156

Freight class 100.



370 Series Recessed Cases

Sliding Door Number	Hinged Door Number	Size H-W	Weight* Lbs.
372	372H	4' x 4'	135
373	373H	4' x 6'	204
374	374H	4' x 8'	272
375	375H	4' x 10'	340
376	376H	4' x 12'	408
378	378H	4' x 16'	544

4' and 6' cases have 1 pair sliding doors, 8' and 10' cases have 2 pair, and 12' and 16' have 3 pair.

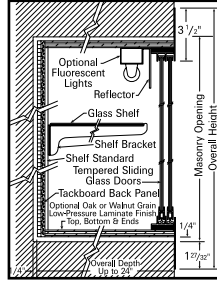

Large Door Display Cases

Number	Size H-W	Shipping* Weight
394	6' x 6'	360 lbs.
395	6' x 8'	480 lbs.
396	6' x 10'	600 lbs.
397	6' x 12'	720 lbs.
398	6' x 14'	840 lbs.
399	6' x 16'	960 lbs.

6' and 8' cases have 2 pair of sliding doors; 10' cases have 3 pair; and 12', 14' and 16' units have 4 pair.

Large Door Detail

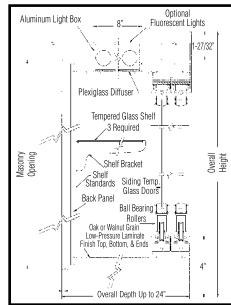

Series 370 and 390 Recessed Trophy Cases

Features:

- Aluminum fronts with satin anodize finish
- Tackable back panels in Claridge Cork, Fabricork, Hook-Fab, Designer Fabric or Tan Nucork
- Low-pressure laminate back panels in Oak or Walnut finish
- 3/16" tempered glass doors with finger pulls, locks and keys
- Three 6, 8, 10 or 12-inch wide adjustable glass shelves with standards and brackets (specify width required when ordering)

Options:

- Wood Box - specify depth (up to 24") - 16" depth standard - and finish - walnut or oak low pressure laminate
- Fluorescent light
- Medium or Dark Bronze Anodize, or Powder Coat Finish
- Hinged Doors, Radius and Fluted Fronts (370 Cases only)
- Custom Styles and Sizes

Masonry opening size for 370 and 390 cases is 3-11/16" smaller in both height and width than O.A. case size.



Series 390

*For weight of unit with wood box, add approx. 5 lbs. per sq. ft. for OA case size to weight shown. Freight Class 125.

Premiere Freestanding or Wall Mounted Display Cases

Features:

- Heavy gauge aluminum frame - satin finish
- 3/16" tempered glass sliding doors with locks
- Three each 6, 8, 10 or 12" wide adjustable glass shelves
- Tackable back panel in Claridge cork, Fabricork, Hook-Fab, Designer Fabric or Tan Nucork
- Low-pressure laminate back panels in Oak or Walnut grain finish
- Aluminum legs and bases of Freestanding cases are 18" high; OA height 5'6"; floor leveling glides included
- Wall mounted cases OA height 4'0"; furnished with angle hangers
- 13-3/4" ID, 16" OD
- Two and three section cases made in one piece

Options:

- Medium or Dark Bronze Anodize or Powder Coat Finish
- Fluorescent Lights
- Intermediate Sizes



Premiere Display Cases

Freestanding Alum. Legs	Wood Base	Wall Mounted	Case Width
456	470	479	3'0"
457	471	481	4'0"
458	472	482	5'0"
463	474	483	6'0"
465	475	485	8'0"
467	476	486	10'0"
469	478	488	16'0"

3', 4', 5' and 6' cases have 1 pair sliding doors; 8' and 10', 2 pair; 12' and 16', 3 pair.

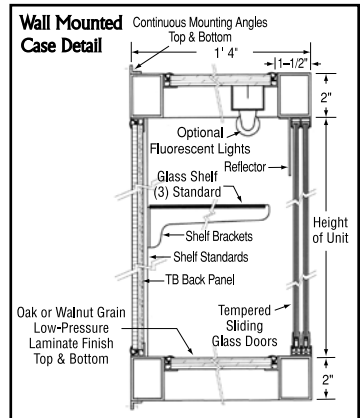

No. 517-4CH



Lecture Unit	Credenza	Size	Type Wood and Finish
508-4WN	604-4WN	4'	Walnut natural lacquer
508-4WO	604-4WO	4'	Walnut with oil
508-6WN	604-6WN	6'	Walnut natural lacquer
508-6WO	604-6WO	6'	Walnut with oil
509-4N	602-4N	4'	Oak natural lacquer
509-4M	602-4M	4'	Oak medium finish
509-4D	602-4D	4'	Oak dark finish
509-6N	602-6N	6'	Oak natural lacquer
509-6M	602-6M	6'	Oak medium finish
509-6D	602-6D	6'	Oak dark finish
512-4MS	603-4MS	4'	Mahogany stained
512-6MS	603-6MS	6'	Mahogany stained
516-4MA	616-4MA	4'	Maple with natural finish
516-6MA	616-6MA	6'	Maple with natural finish
517-4CH	617-4CH	4'	Cherry with stain
517-6CH	617-6CH	6'	Cherry with stain
518-4PL		4'	Plastic Laminate
518-6PL		6'	Plastic Laminate

Conference Room Chalkboards, Markerboards, Tackboards and Combination Units

- 2" dark finish oak frame with black accent strip (natural or medium oak at no additional cost)
- LCS markerboard or Vitracite chalkboard writing surface
- Markerboards, Chalkboards, and Combination units have marker tray
- Tackboards are available with Claridge Cork, Fabricork, Designer Fabric, Hook-Fab and Tan Nucork
- Combination units available with any of the above materials
- Keyhole hangers furnished



No. 210E

Options:

- Genuine walnut, mahogany, maple or cherry optional
- Map rail optional
- Custom match finishes

Chalkboard/ Markerboard	Tackboard	Combination	Size (H - W)
210	213	210E	4' x 4'
210A	213A	210F	4' x 6'
210B	213B	210G	4' x 8'
210C	213C	210H	4' x 10'
210D	213D	210K	4' x 12'

Contemporary Style Lecture Units and Credenzas

Cabinet Features:

- Radius corners (except 518's); square corners optional
- White LCS-II low gloss porcelain enamel writing surface
- 1691 Quartz Designer Fabric bulletin board inside doors (other fabrics and colors optional)
- Concealed hangers for easy and secure installation
- Lecture units 3-3/4" deep; credenzas 16" deep

Credenza Features:

- Radius Corners
- Two Shelves
- Recessed Toe Space
- Hinged Doors; ball catches; wooden door knobs

Accessories:

- 1 white sketching pad
- 4 LCS markers and 1 eraser
- Display Rail with cork insert
- Spring clip hooks for charts

Options:

- Matte White projection screen
- Fluorescent Light
- LCS inside doors in lieu of bulletin board
- Laminate lecture units with square corners
- Lock and Keys

Note: 4' Credenzas have two doors, 6' Credenzas have three.

No. 604-4WN
Credenza with matching
No. 508-4WN Lecture
Unit. Both are walnut
with natural finish.



Wood Finishes

Wood finish color samples are reproduced with reasonable accuracy. If match is critical call or write for actual samples. Custom match finishes optional.



Natural Oak



Medium Oak



Dark Oak



Ebony



Walnut Natural



Walnut Oil



Mahogany Stain



Maple Natural



Cherry Stain

Specification Information

GENERAL

DESCRIPTION OF WORK

Section Includes:

1. Porcelain enamel chalkboards
2. Porcelain enamel markerboards
3. Tackboards and accessories
4. Marker Walls and Tack Walls
5. Vertical and Horizontal sliding units

Related Sections:

1. Directories
2. Display Casework

REFERENCED STANDARDS

- A. ASTM-E 84
- B. ASTM B221

SUBMITTALS

- A. Shop Drawings: Provide shop drawings for each type of visual display board required.
- B. Product Data: Provide technical data for materials specified. Include Material Safety Data Sheets, when applicable.
- C. Samples:
 1. Manufacturer's color charts
 2. Composition samples of face, core, backing material and trim to illustrate finish, color and texture.

OPERATION & MAINTENANCE

Include data on regular cleaning, stain removal, and precautions

REGULATORY REQUIREMENTS

Conform to applicable code for flame/smoke rating in tackboards in accordance with ASTM-E 84.

QUALITY ASSURANCE

Provide items in this section as manufactured by: Claridge Products and Equipment, Inc. Harrison, Arkansas 72602-0910 Phone: 870/743-2200 Fax: 870/743-1908

FIELD CONDITIONS

Field measure prior to preparation of shop drawings and fabrication to ensure proper fit.

WARRANTY

Submit "Life of the Building" warranty, stating that under normal usage and maintenance, and when installed in accordance with manufacturer's instructions and recommendations, Claridge porcelain enamel steel chalkboards and markerboards are guaranteed for the life of the building. Guarantee covers replacement of defective boards but does not include removal or reinstallation cost.

PRODUCTS

MANUFACTURERS

Visual display boards - chalkboards, markerboards, and tackboards - as manufactured by: Claridge Products & Equipment, Inc., Harrison, Arkansas 72602

MATERIALS

- A. All visual display boards shall be Series ____ (architect to select from Series 1, 3, 4, 5, 8 or 185) factory laminated and factory framed chalkboards, markerboards or tackboards.
- B. Porcelain enamel Markerboards/Chalkboards: All porcelain enamel markerboards and chalkboards shall be manufactured in accordance with the Porcelain Enamel Institute's specifications. The steel surface is pre-cleaned to ensure complete bond between the steel and the porcelain surface.
 1. LCS Markerboard and Vitracite Chalkboard: Made from aluminized steel sheets, the porcelain enamel surface is fusion bonded to one side during a single process and is fired at lowest possible temperature to reduce steel and porcelain stresses and achieve superior enamel bond and hardness.
 2. LCS-II Markerboard: Made from cold-rolled steel, during a 3-coat process both steel surfaces receive a ground coat of porcelain enamel. Then, a color cover coat of porcelain is applied to one

surface of the ground coat and is fusion bonded to the steel substrate at temperature necessary to reduce steel and porcelain stresses.

- a. Face Sheet: LCS, LCS-II or Vitracite
 - b. Core Material: 7/16" Medium Density Fiberboard (MDF)
 - c. Backing: Moisture barrier back
3. Laminations: Shall be hot-type neoprene contact adhesive applied to both surfaces automatically. Each substrate to have minimum of 80% covering with 1.5-2.0 dry mils of adhesive. Panel components shall have uniform pressure applied mechanically over entire area. Laminations shall be made by face sheet manufacturer.
 4. Sizes: Standard height is 4 feet. Porcelain markerboards and chalkboards shall be available in single piece lengths up to 16 feet.
- C. Tackboards: Architect to select from tackboards composed of 1/4" thick self-healing, burlap backed Claridge cork; Fabricork vinyl fabric on cork underlay; Hook-Fab fabric on cork underlay; Designer polyester fabric on cork underlay; or 1/4" Tan Nucork, all on 1/4" hardboard backing.
- D. Metal Trim and Accessories: Provide Series ____ aluminum extrusions as manufactured by Claridge Products and Equipment, Inc. Trim shall be heavy gauge extruded aluminum and shall meet or exceed ASTM B221 Alloy Standards. Finish to be etched and anodized satin finish standard. Color Anodized and Powder Coat Paint finished trim optional.

- Chalktray/Marker Tray: Standard continuous, solid type aluminum Chalk Tray/Marker Tray with ribbed section and injection molded end closures, or standard continuous hollow tray with injection molded end closures; metal end closures optional.
- Map Rail: Standard continuous 1" (2" optional) map rail with cork insert and end stops at the top of each chalkboard or markerboard, complete with the following accessories:
1. Map Hooks: Provide 2 map hooks for each 4 feet of map rail.
 2. Roller Brackets: Provide ____ per map rail.
 3. Flag Holder: Provide ____ per map rail.
- E. Colors: As selected from manufacturer's standard colors. Color charts on request.
 - F. Adhesive: As recommended by manufacturer.

FABRICATION

- A. Shop assembly: Provide factory assembled chalkboard, markerboard, and tackboard units, except where field assembled units are required.
 1. LCS or LCS-II Porcelain Enamel Steel Markerboards or Vitracite Porcelain Enamel Steel Chalkboards
 - a. Face Sheet: Porcelain Enamel Steel
 - b. Core: 7/16" MDF
 - c. Backing: Moisture barrier back
 2. Claridge Cork Tackboards
 - a. Face Sheet: 1/4" cork
 - b. Binder: burlap
 - c. Backing: 1/4" hardboard

EXECUTION

PROJECT CONDITIONS

- A. Verify before installation that interior moisture and temperature approximate normal occupied conditions.
- B. Verify that wall surfaces are prepared and ready to receive boards.

INSTALLATION

- A. Deliver factory built units completely assembled in one piece without joints wherever possible. Where dimensions exceed panel size, provide 2 or more pieces of equal length as acceptable at the factory,

disassemble for delivery, and make final joints at the job site. Use H-bar at joints to maintain alignment.

- B. Follow manufacturer's instructions for storage and handling of units before installation.
- C. Install level and plumb, keeping perimeter trim straight in accordance with manufacturer's recommendations.

ADJUST AND CLEAN

- A. Verify that all required accessories are installed for each unit.
- B. At completion of work, clean surfaces and

trim in accordance with manufacturer's recommendations, leaving all materials ready for use.

See www.claridgeproducts.com for complete specifications and CAD library.

Touchboards

205 Westwood Ave, Long Branch, NJ 07740
Phone: 866-94 BOARDS (26273) / (732)-222-1511
Fax: (732)-222-7088 | E-mail: sales@touchboards.com