

**TOLERANCES** (Unless otherwise stated)

Decimals	Angles (±0.2°)
500 < ≤2000mm	±0.20mm
200 < ≤500mm	±0.15mm
< 200mm	±0.10mm
500 < ≤2000mm	±0.15mm
< 500mm	±0.10mm

**THIRD ANGLE PROJECTION**

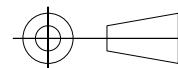

<b>Model No.</b>	6065K+	<b>Scale</b>	1:1	<b>Notes:</b>
<b>Part No.</b>	CTI-6065K+UH20	<b>Rev.</b>	1.0	
<b>Part Name</b>		<b>Size</b>	Free	
<b>Unit</b>	mm	<b>Sheet</b>	1/1	
<b>Material</b>		<b>Chk'd</b>		
<b>Surface</b>		<b>App'd</b>		
<b>Drawn</b>				

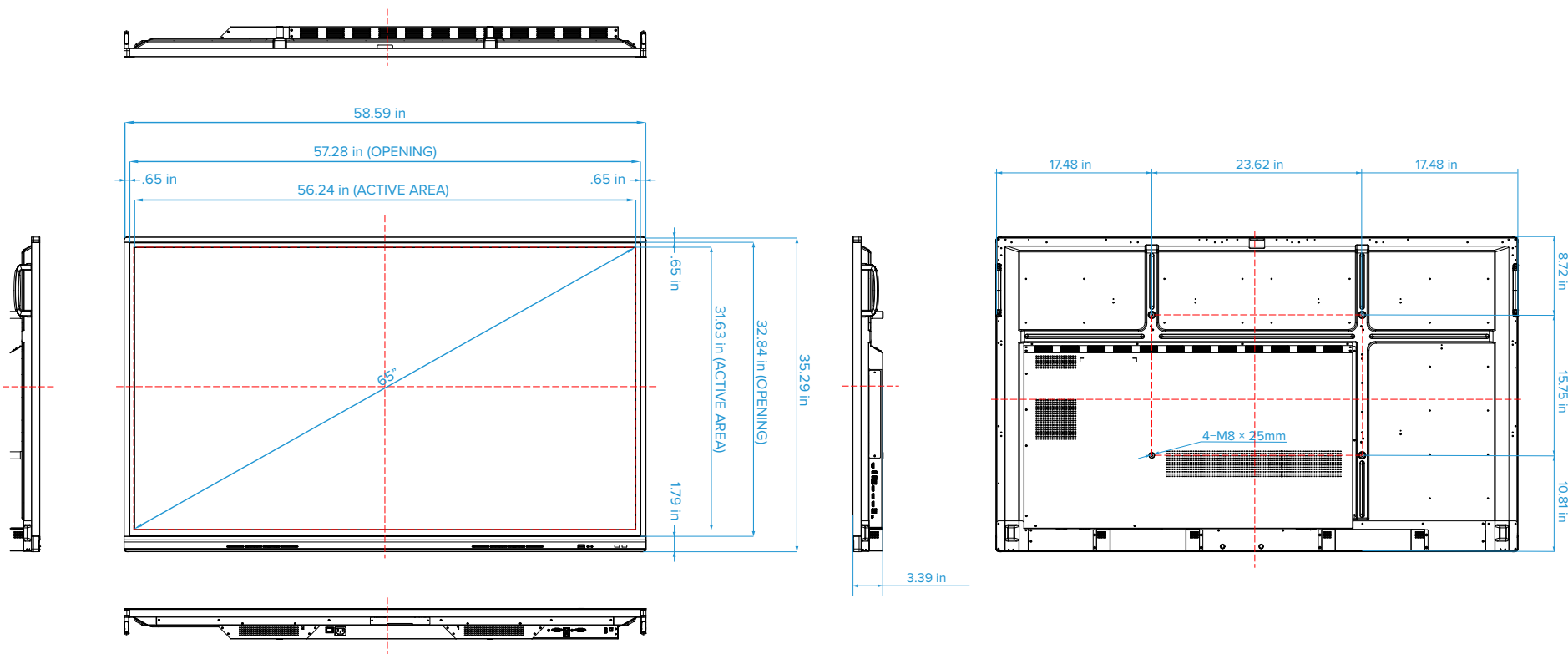

**TOLERANCES** (Unless otherwise stated)

Decimals	Angles ( $\pm 0.2^\circ$ )
500 < $\leq$ 2000mm	$\pm 0.20$ mm
200 < $\leq$ 500mm	$\pm 0.15$ mm
< 200mm	$\pm 0.10$ mm
500 < $\leq$ 2000mm	$\pm 0.15$ mm
< 500mm	$\pm 0.10$ mm

**THIRD ANGLE PROJECTION**

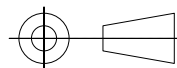

<b>Model No.</b>	6065K+	<b>Scale</b>	1:1	<b>Notes:</b>
<b>Part No.</b>	CTI-6065K+UH20	<b>Rev.</b>	1.0	
<b>Part Name</b>		<b>Size</b>	Free	
<b>Unit</b>	in	<b>Sheet</b>	1/1	
<b>Material</b>		<b>Chk'd</b>		
<b>Surface</b>		<b>App'd</b>		
<b>Drawn</b>				