

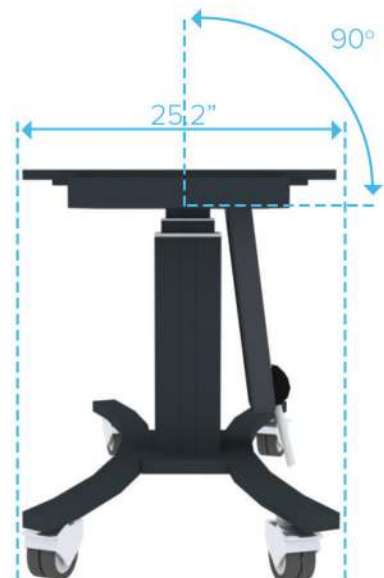

CONVERTIBLE MOBILE STAND

**MOTORIZED HEIGHT/TILT ADJUSTMENT
FOR USE WITH MODELS UP TO 6075U+**

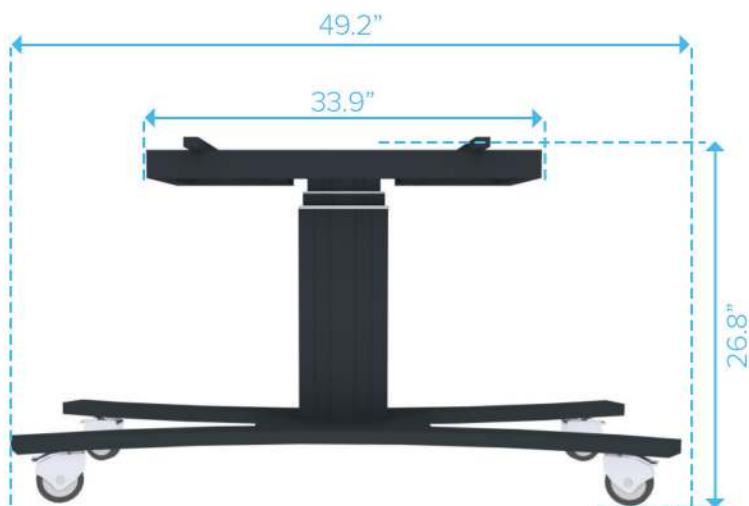

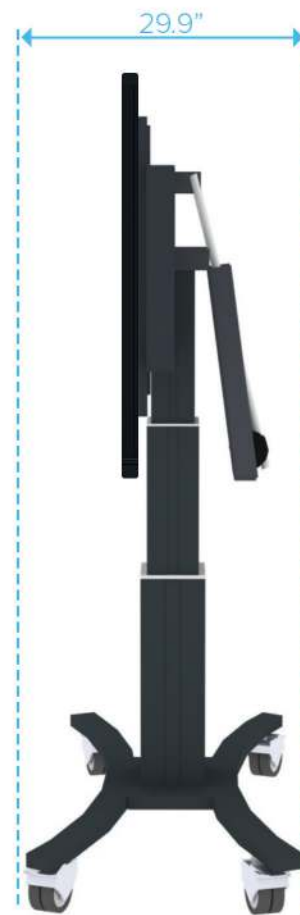
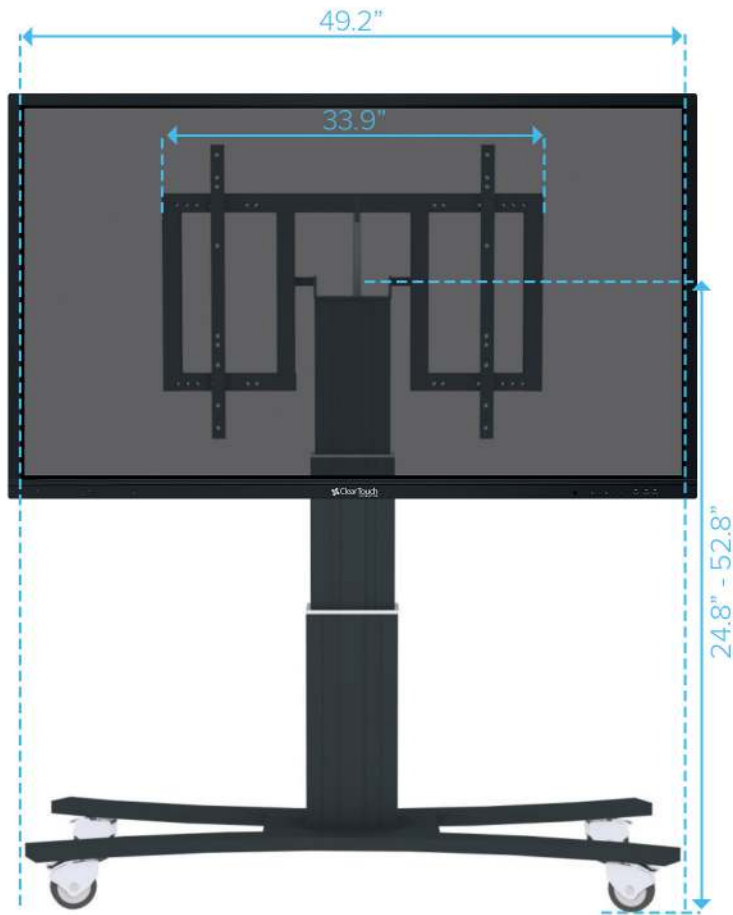

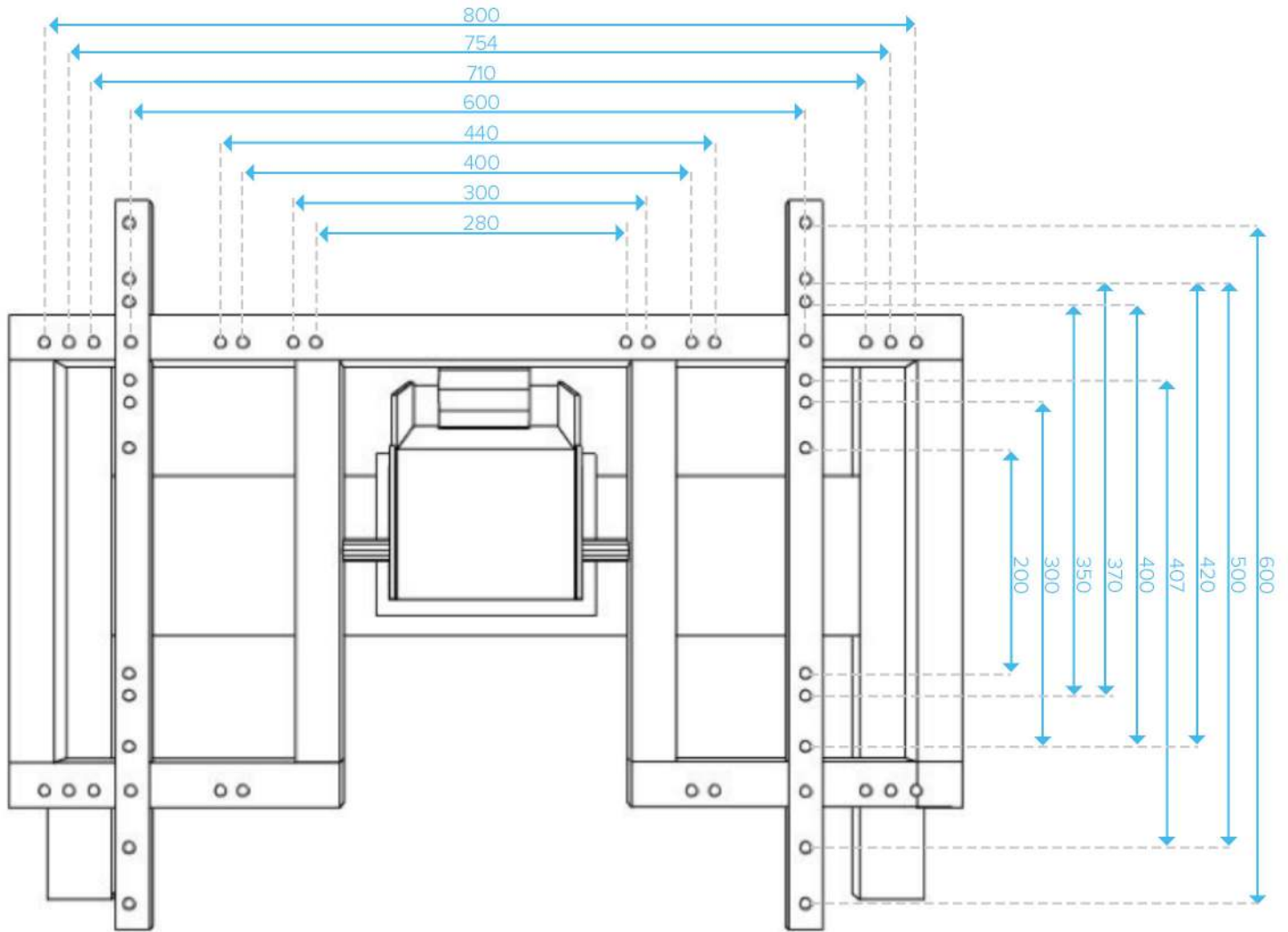

CONVERTIBLE MOBILE STAND PRODUCT FEATURES

- Motorized mobile stand offering height & tilt adjustment
- Designed for use with 55"–75" displays with max.
- VESA 200x200 up to 800x600
- Weight load capacity 300 lbs
- 28" height adjustment
- Display mount with external actuator, offering 90° tilt, with 2 "Lock & Release" brackets
- Mobile base with C-style open frame
- UL 60950-1 certified
- ADA compliant
- Complete system in color black
- 5 year warranty on all components



PART NO.	DESCRIPTION	PACKING DIMENSIONS	NET WEIGHT	GROSS WEIGHT
CTI-STAND-MCCM	Motorized Center Column Multi – 3 Tier Motorized Column (24.8" to 52.8")	32.3" x 10.6" x 8.7"	49.5 lbs	53.0 lbs
CTI-MOUNT-TADM-V2	Display Mount, Tilt Acuator with Four Button Control	35.0" x 30.3" x 18.9"	48.7 lbs	59.1 lbs
CTI-STAND-MBBL-V2	Mobile Base, C-Style Open Frame, Recessed	53.1" x 30.7" x 4.7"	28.2 lbs	34.2 lbs
			126.4 lbs	146.2 lbs