

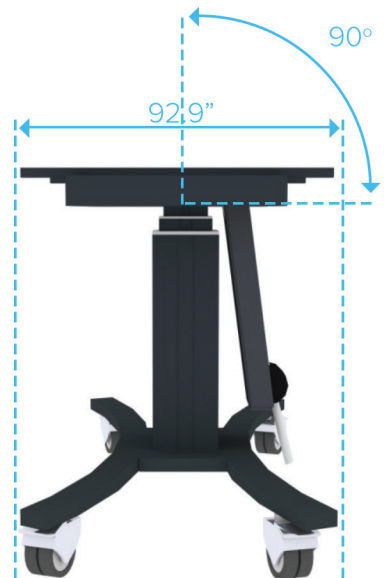

CONVERTIBLE MOBILE STAND

MOTORIZED HEIGHT/TILT ADJUSTMENT FOR USE WITH MODELS UP TO 5084+

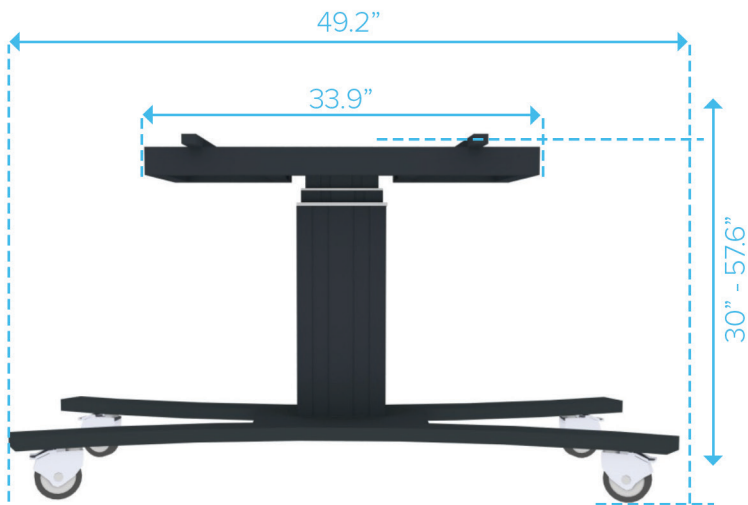

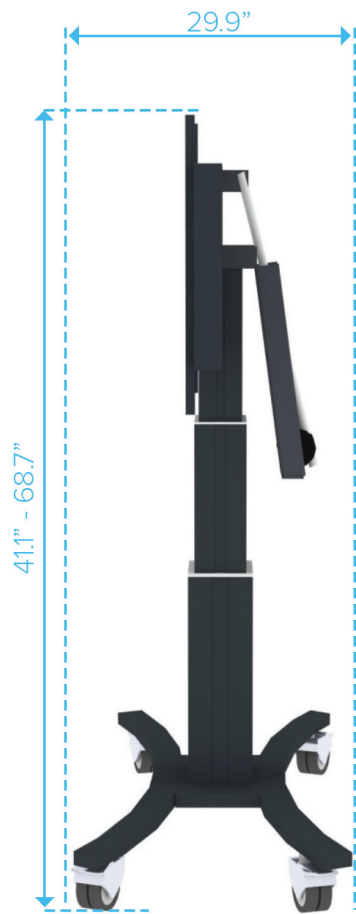
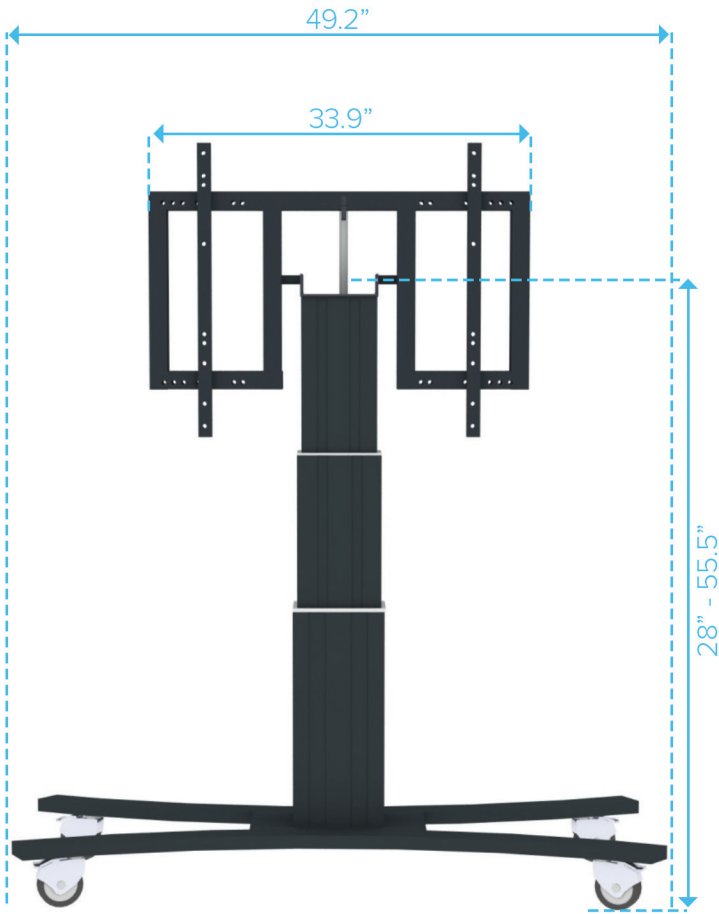

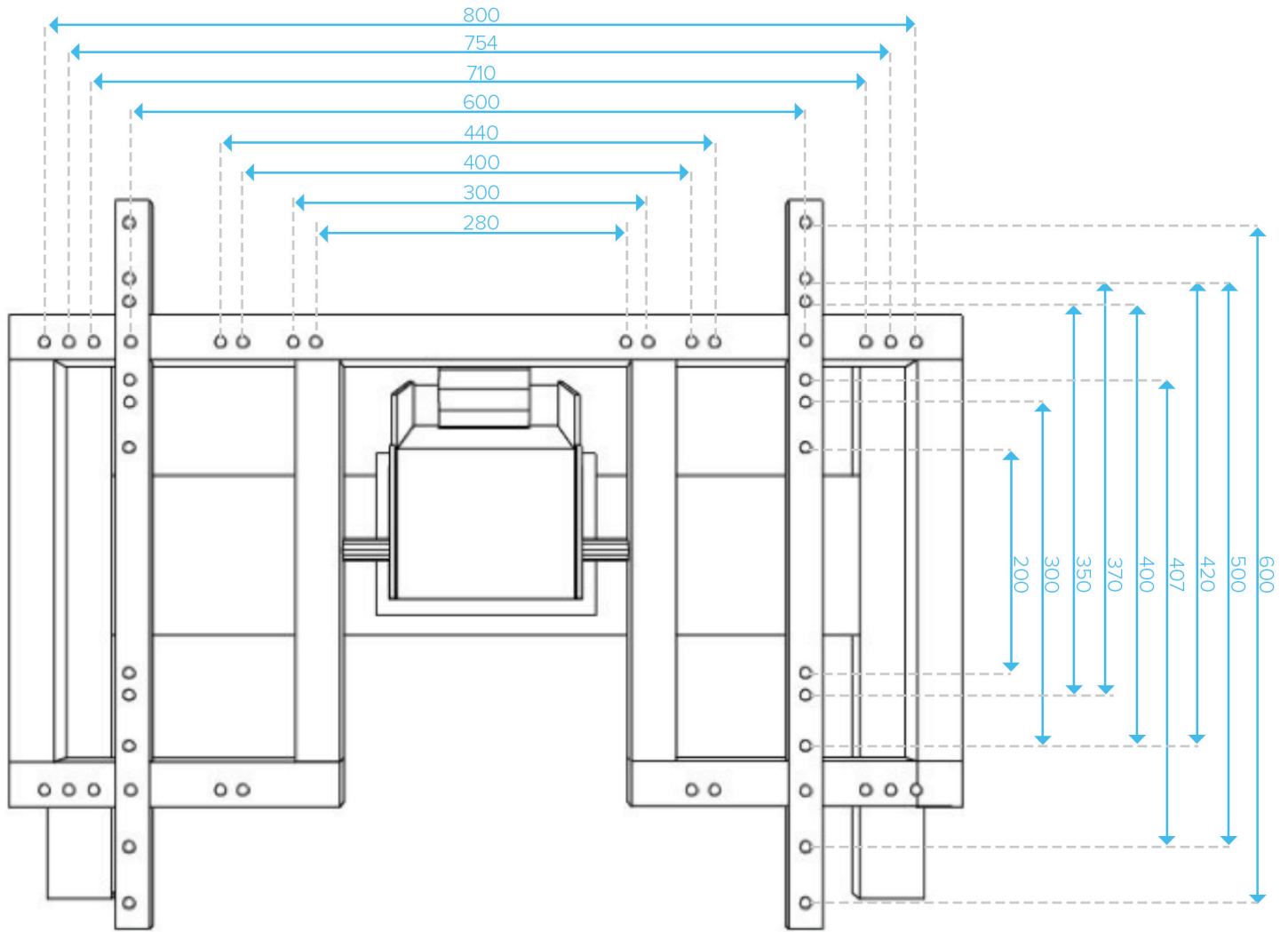

CONVERTIBLE MOBILE STAND PRODUCT FEATURES

- Motorized mobile stand offering height & tilt adjustment
- Designed for use with 55" – 84" displays with max. VESA 800x600
- Weight load capacity 330 lbs
- 28" height adjustment
- Display mount with external actuator, offering 90° tilt, with 2 "Lock & Release" brackets
- Mobile base with C-style open frame
- ADA compliant
- Complete system in color black
- 3 year warranty on motorized parts
- 5 year warranty on base and display mount

PART NO.	DESCRIPTION	PACKING DIMENSIONS	NET WEIGHT	GROSS WEIGHT
CTI-STAND-MCCM	Motorized Center Column Multi – 3 Tier Motorized Column (29.75" to 57.25")	32.3" x 10.6" x 8.7"	49.5 lbs	52.9 lbs
CTI-STAND-TADM	Display Mount, Tilt Acuator with Four Button Control	35.0" x 30.3" x 18.9"	48.7 lbs	59.1 lbs
CTI-STAND-MBBL	Mobile Base, C-Style Open Frame	53.1" x 30.7" x 4.7"	28.2 lbs	34.1 lbs
			126.4 lbs	146.1 lbs