



ADJUSTABLE MOBILE STAND

MOTORIZED HEIGHT ADJUSTMENT FOR USE WITH MODELS UP TO 5084+



100%
MOBILE

3'-5'
HEIGHT

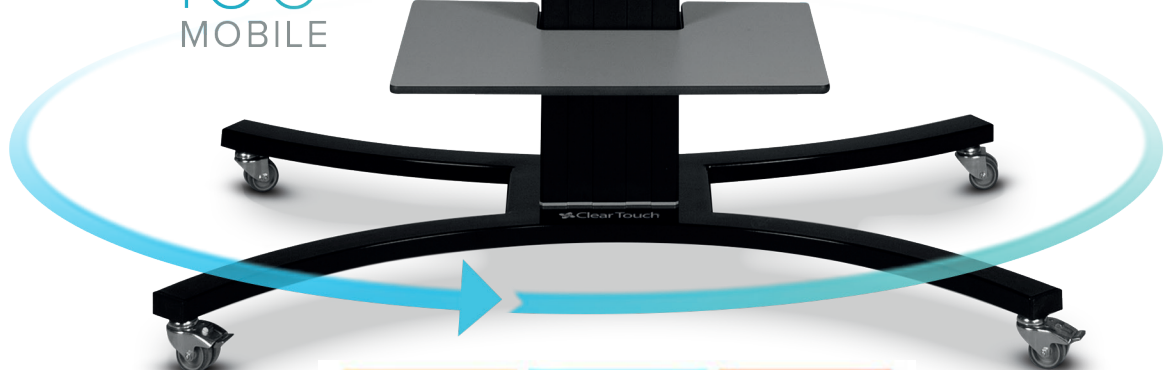

205 Westwood Ave, Long Branch, NJ 07740
Phone: 866-94 BOARDS (26273) / (732)-222-1511
Fax: (732)-222-7088 | E-mail: sales@touchboards.com

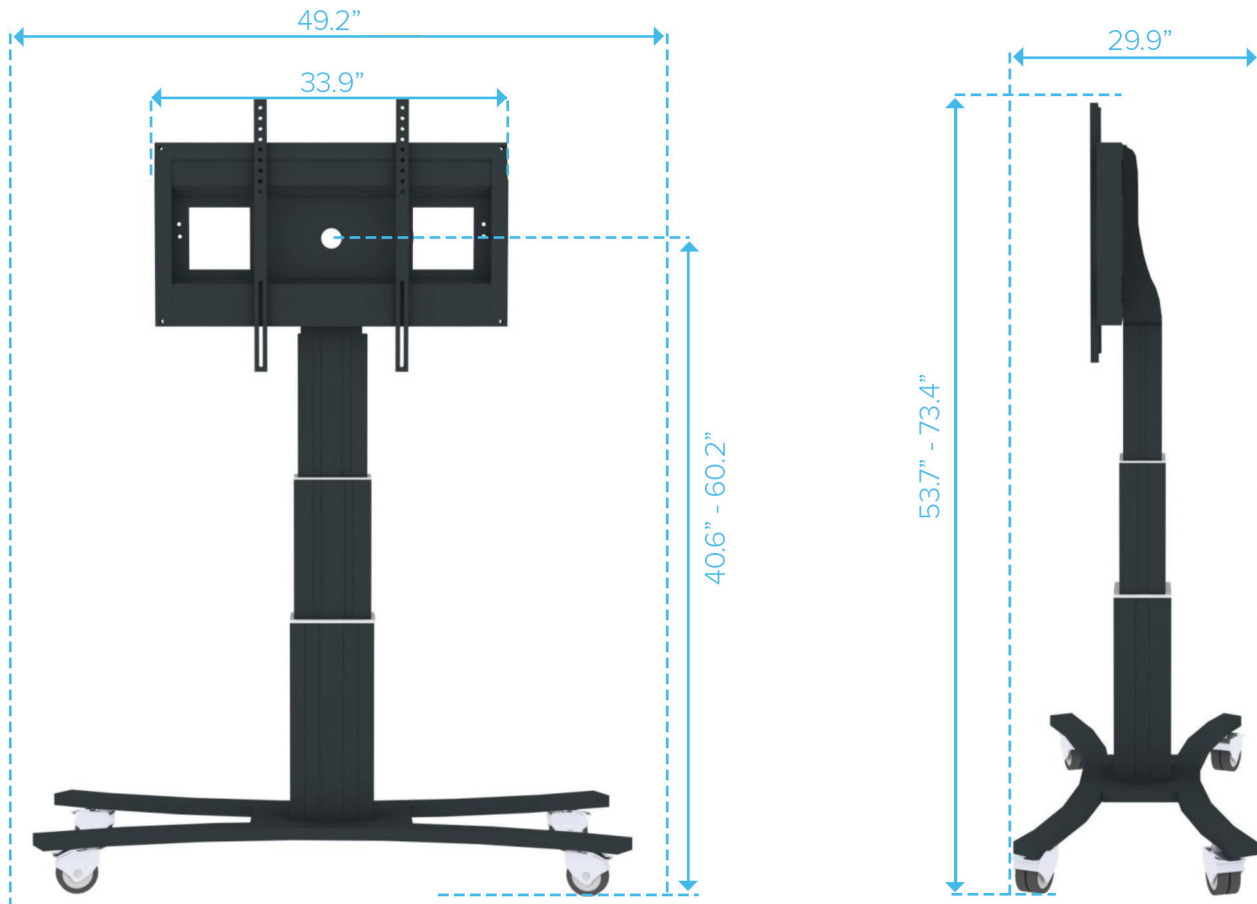

ADJUSTABLE MOBILE STAND PRODUCT FEATURES

- Motorized mobile stand with actuator integrated in aluminum center column, color black
- Designed for use with 55" – 84" displays with max. VESA 800x600
- Weight load capacity 330 lbs
- 28" height adjustment
- Mobile base with C-style open frame
- ADA compliant
- Complete system in color black
- 3 year warranty on motorized parts
- 5 year warranty on base and display mount

PART NO.	DESCRIPTION	PACKING DIMENSIONS	NET WEIGHT	GROSS WEIGHT
CTI-STAND-MCCM	Motorized Center Column Multi – 3 Tier Motorized Column (19.75" to 57.25")	32.3" x 10.6" x 8.7"	49.5 lbs	52.9 lbs
CTI-STAND-FXDM	Display Mount, Fixed with Four Button Control	6.3" x 34.3" x 17.7"	26.5 lbs	30.9 lbs
CTI-STAND-MBBL	Mobile Base, C-Style Open Frame	53.1" x 30.7" x 4.7"	28.2 lbs	34.1 lbs
			104.2 lbs	117.9 lbs