



## PRODUCT SPECIFICATIONS

# Hand-Adjustable Mobile Stand

### Features:

Supports all Clear Touch® panels up to 86"

Adjustable height for all ages

3-year warranty on all components

Manually adjustable stand makes accommodation simple, no power connection needed

C-shaped mobile base provides greater accessibility for all users

Included accessory shelf

27.6" adjustment range

ADA compliant

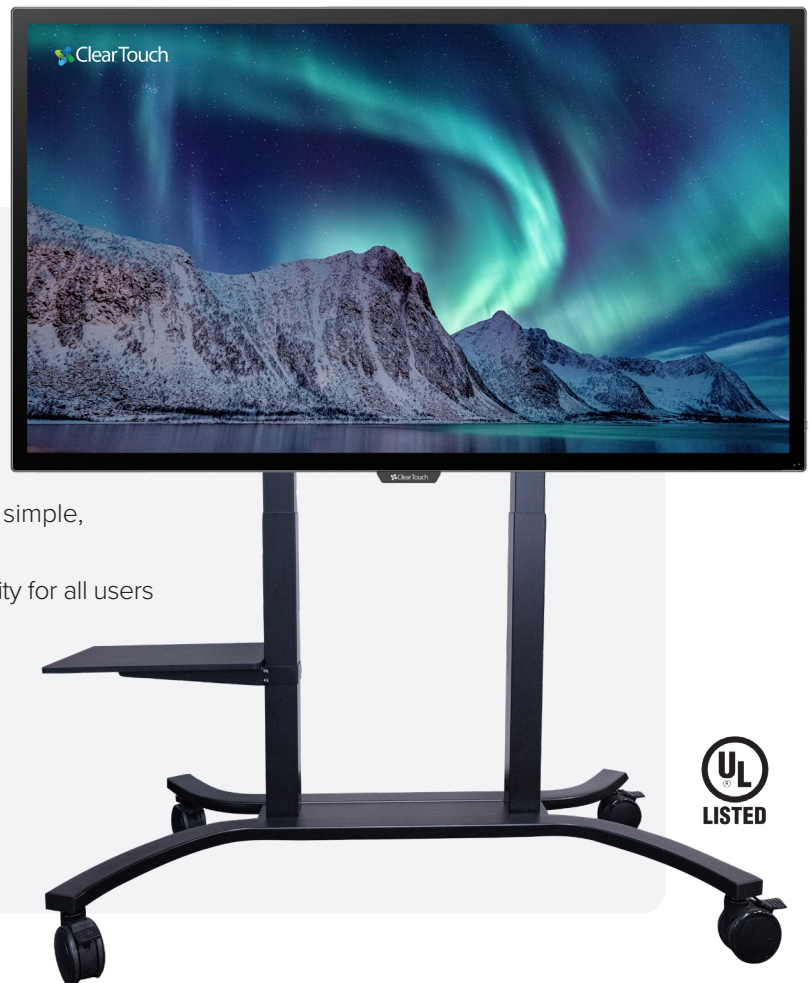

Specification:	
<b>Dimension (LxWxH)</b>	49.57" × 26.46" × (38.39" - 58.07") / 1259 × 672 × (975-1475) mm
<b>Dimension with Package (LxWxH)</b>	53.54" × 29.92" × 3.74" / 1360 × 760 × 95 mm
<b>Net Weight</b>	62.83 lbs / 28.5 kg
<b>Gross Weight</b>	69.67 lbs / 31.6 kg
<b>Max Loading Weight</b>	220.46 lbs / 100 kg
<b>Lifting Distance</b>	19.68" / 500 mm
<b>Castor</b>	4 inch, muting wheels
<b>Matching Wall Mount</b>	Standard Match Wall Mount

Front view



Back view

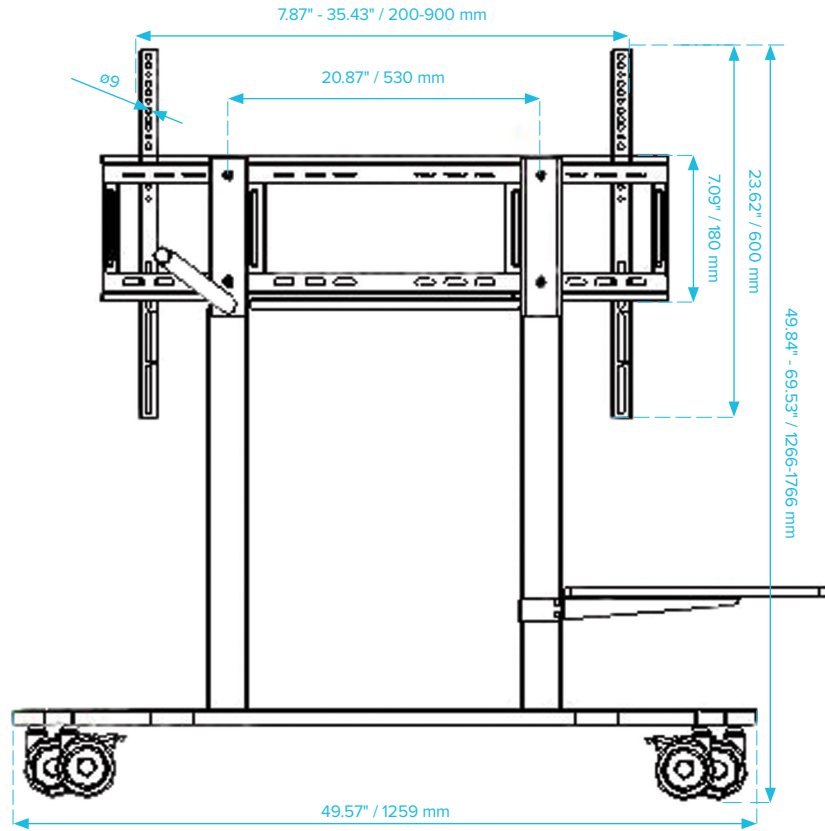

Left-side view

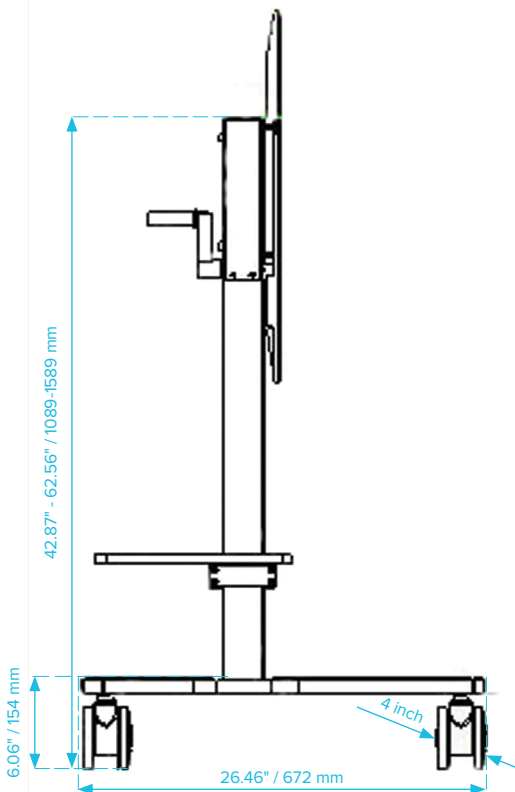

Top-down view

