

INSTRUCTION MANUAL

For

**BULK CURRENT
INJECTION PROBE**

Model: **CLCI-100**

and

CALIBRATION FIXTURE

Model: **FCLC-100**

(optional)

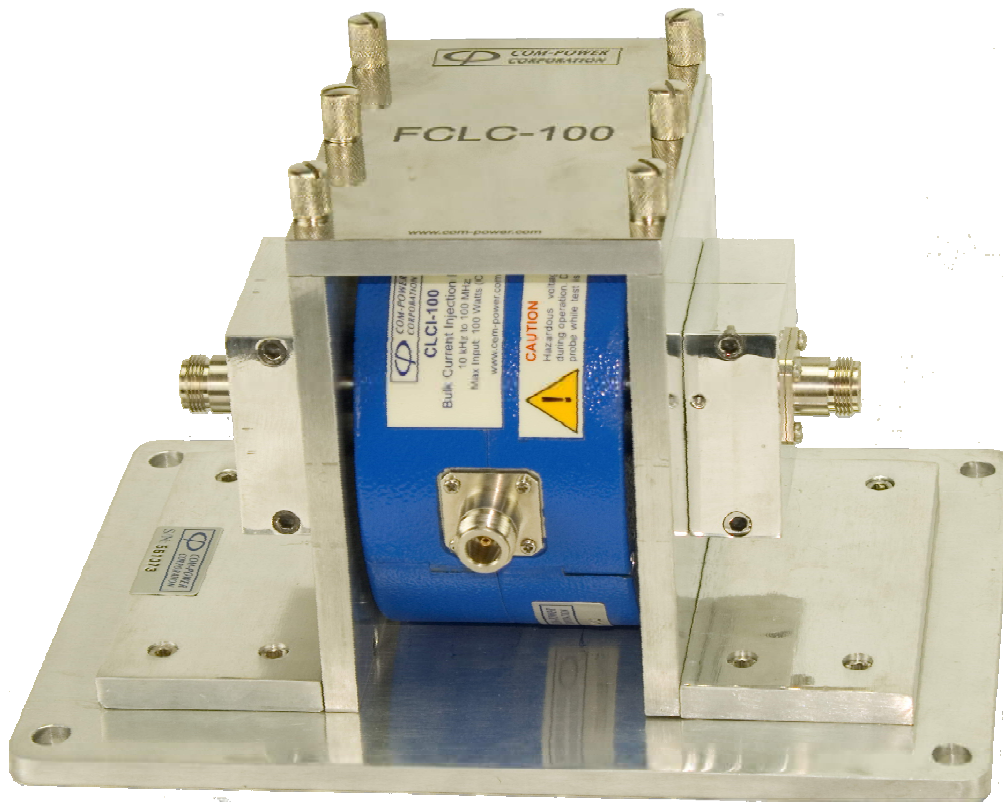

Table of Contents

1.0 Introduction	4
2.0 Products Available from Com-Power	5
3.0 Product Information	6
3.1 Incoming Inspection	6
3.2 Package Inventory	6
3.3 Product Safety Information	7
3.3.1 Product Hazard Symbols Definitions.....	7
3.3.2 Product Warning/Caution Statements.....	7
3.3.3 General Safety Instructions.....	7
3.4 Product Features	8
3.4.1 Description of CLCI-100 Bulk Current Injection Probe Features	8
3.4.2 Description of FCLC-100 Calibration Fixture Features.....	9
3.5 Product Specifications	10
3.5.1 Specifications for CLCI-100 Bulk Current Injection Probe.....	10
3.5.2 Specifications for FCLC-100 Calibration Fixture	10
3.6 Product Dimensional Diagrams	11
3.6.1 Dimensions of CLCI-100 Bulk Current Injection Probe.....	11
3.6.2 Dimensions of FCLC-100 Calibration Fixture	12
4.0 Using the CLCI-100 Probe with the FCLC-100 Fixture.....	13
4.1 Installation of CLCI-100 Probe into FCLC-100 Fixture	13
4.2 Insertion Loss/Coupling Factor Measurement.....	14
4.3 Transfer Impedance Factors	15
4.4 Conducted Immunity Test Level Calibration (IEC 61000-4-6)	16
4.4.1 Test Generator Equipment (Method A vs Method B)	16
4.4.2 Calibration-related Calculations.....	18
4.4.2.1 Test Level Calculations	18
4.4.2.2 Test Level Offset Calculations	19
4.4.2.3 Test Frequency Calculations	19
4.4.3 Equipment Setup	20
4.4.4 Level Setting Process.....	22
4.4.5 Amplifier Saturation Check.....	23
4.4.6 Running the Test	24
4.5 Conducted Susceptibility Test Level Calibration (50Ω System).....	26
5.0 Warranty.....	27
6.0 Typical CLCI-100 Calibration Data.....	28

List of Figures

FIGURE 1 -	CLCI-100 Bulk Current Injection Probe Features	8
FIGURE 2 -	FCLC-100 Calibration Fixture Features	9
FIGURE 3 -	Dimensional Diagram for CLCI-100 Bulk Current Injection Probe	11
FIGURE 4 -	Dimensional Diagram for FCLC-100 Calibration Fixture	12
FIGURE 5 -	Installation of CLCI-100 Probe into FCLC Calibration Fixture	13
FIGURE 6 -	Setup for Insertion/Coupling Loss in a 50 Ω System (100 Ω Loop)	14
FIGURE 7 -	Setup for Insertion/Coupling Loss in a 150 Ω System (300 Ω Loop)	14
FIGURE 8 -	Equivalent Schematic of Calibration Circuit	15
FIGURE 9 -	Examples of Test Generator Systems	16
FIGURE 10 -	Setup for Calibration Accessories for 150 Ω System	20
FIGURE 11 -	IEC 61000-4-6 (Method A) Test Level Calibration Setup	20
FIGURE 12 -	IEC 61000-4-6 (Method B) Test Level Calibration Setup	21
FIGURE 13 -	IEC 61000-4-6 (Method A) Test Setup	24
FIGURE 14 -	IEC 61000-4-6 (Method B) Test Setup	25
FIGURE 15 -	Test Level Calibration into 50 ohm System	26

1.0 Introduction

This manual includes descriptions of the CLCI-100 Bulk Current Injection Probe connections, product specifications, safety precautions, operational instructions, calibration instructions, measurement guidelines and warranty information.

Information contained in this manual is the property of Com-Power Corporation. It is issued with the understanding that the material may not be reproduced or copied without the express written permission of Com-Power.

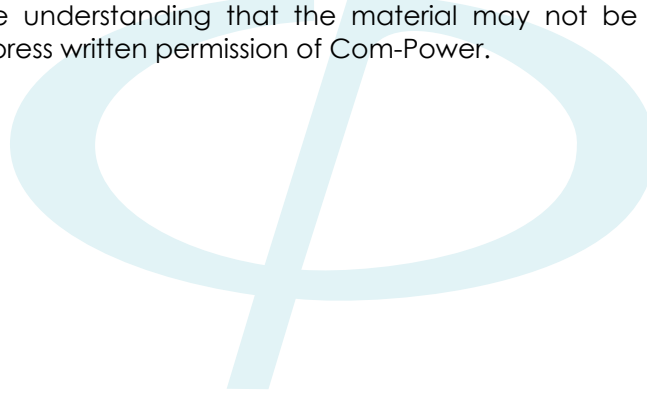

2.0 Products Available from Com-Power



www.com-power.com

3.0 Product Information

3.1 Incoming Inspection

If there is any evidence of shipping damage. If shipping damage to the product or any of its accessories is suspected, or if the package contents are not complete, contact Com-Power or your Com-Power distributor.

Please check the contents of the shipment against the package inventory in section 3.2 to ensure that you have received all applicable items.

3.2 Package Inventory

STANDARD ITEMS:

- ✓ CLCI-100 Bulk Current Injection Probe
- ✓ Calibration Certificate and Associated Data

OPTIONAL ITEMS:

- ✓ FCLC-100 Calibration Fixture
- ✓ ADA-515-2 150Ω to 50Ω Adapter Set
- ✓ ATTN-06-100W Power Attenuator (6 dB, 100W)
- ✓ ATTN-30-100W Power Attenuator (30 dB, 100W)
- ✓ TERM-100W Termination (50Ω)
- ✓ DCD-1000-100W Dual Directional Coupler

3.3 Product Safety Information

3.3.1 Product Hazard Symbols Definitions

The hazard symbols appearing on the product exterior are defined below.



The yellow triangle with an exclamation mark indicates the presence of important operating and/or maintenance (servicing) instructions in the literature accompanying the product.

3.3.2 Product Warning/Caution Statements

CAUTION: Hazardous voltages present during operation. Do not handle probe while test is in progress.

3.3.3 General Safety Instructions

The following safety instructions have been included in compliance with safety standard regulations. Please read them carefully.

- **READ AND RETAIN INSTRUCTIONS** - Read all safety and operating instructions before operating the instrument. Retain all instructions for future reference.
- **HEED WARNINGS** - Adhere to all warnings on the instrument and operating instructions.
- **FOLLOW INSTRUCTIONS** - Follow all operating and use instructions.
- **WATER AND MOISTURE** - Do not use the instrument near water.
- **WALL OR CEILING MOUNTING** - Do not mount the instrument on a wall or ceiling.
- **HEAT** - The instrument should be situated away from heat sources such as heat registers or other instruments which produce heat.
- **POWER SOURCES** - Connect the instrument only to the type of power source described in the operating instructions or as marked on the instrument.
- **POWER CORD PROTECTION** - Place power supply cords so that they are not likely to be walked on or pinched by items placed on them or against them.
- **CLEANING** - Clean the instrument only as recommended by the manufacturer.
- **DEFECTS AND ABNORMAL STRESS** - Whenever it is likely that the normal operation has been impaired, make the equipment inoperable and secure it against further operation.
- **DAMAGE REQUIRING SERVICE** - Instrument should be serviced by qualified personnel when:
 - ✓ The power supply cord or the plug has been damaged.
 - ✓ Objects have fallen or liquid has been spilled into the instrument.
 - ✓ The instrument has been exposed to rain.
 - ✓ The instrument does not appear to operate normally.
 - ✓ The instrument has been dropped, or the enclosure has been damaged.
- **SITTING OR CLIMBING** - Do not sit or climb upon the instrument or use it as a step or ladder.

3.4 Product Features

3.4.1 Description of CLCI-100 Bulk Current Injection Probe Features

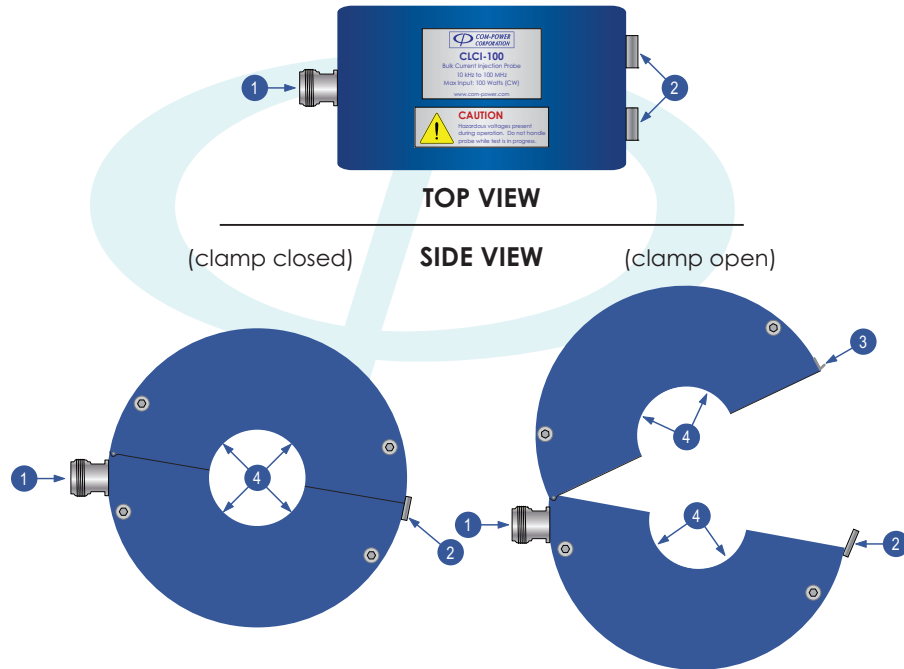

FIGURE 1 - CLCI-100 Bulk Current Injection Probe Features

- 1 Input/Output Port**
When used for bulk current injection, this is the input port of the probe. When used as a measuring device, this is the probe's output port. It is fitted with an N-type coaxial connector.
- 2 Spring-loaded Clasps**
These two (2) clasps, when secured over their respective brackets, lock the clamp into its closed position.
- 3 Clasp Brackets**
These two (2) brackets anchor the respective clasp brackets in order to lock the clamp into its closed position.
- 4 Clamp Window**
This clamp window is an aperture in the center of the clamp through which the wire(s), cable(s) or cable bundle(s) to be tested are passed through.

3.4.2 Description of FCLC-100 Calibration Fixture Features

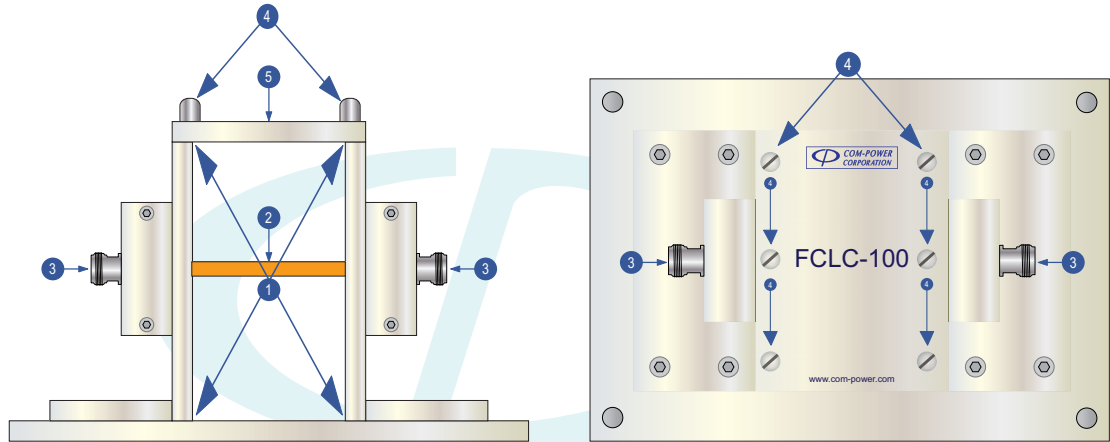

FIGURE 2 - FCLC-100 Calibration Fixture Features

- 1 Fixture Opening**
The CLCI-100 is installed within this opening so that the center conductor rod of the fixture passes through the approximate center of the probe aperture.
- 2 Center Conductor Rod**
This is the fixture's center conductor.
- 3 Calibration Fixture Coaxial Ports**
These are female N-type coaxial connectors providing input/output connections to the fixture.
- 4 Thumb Screws for Removable Top Plate**
These (6) screws secure the fixture's top plate to the fixture assembly.
- 5 Removable Top Plate of Fixture**
In order to install/remove the clamp into/from the calibration fixture, the top plate must be removed by removing the six (6) thumb screws. The top cover and thumb screws must be replaced prior to the performance of tests.

3.5 Product Specifications

3.5.1 Specifications for CLCI-100 Bulk Current Injection Probe

Technical

Product	Bulk Current Injection Probe
Model	CLCI-100
Frequency Range	10 kHz to 100 MHz
Standard(s)	IEC 61000-4-6, MIL-STD 461x, RTCA-DO-160x, etc
Impedance	50Ω (nominal)
Transfer Impedance Factors	see graph(s) located in Section 6
Maximum Input Power	100 Watts (continuous)

Mechanical

Coaxial RF Connector	N-type (female)
Dimensions (H)x(W)x(L)	5" x 2.75" x 5.78" (12.75 x 7 x 14.7 cm)
Probe Aperture Diameter	1.575" (4 cm)
Weight	4.5 lbs (2.04 kg)

Environmental

Operating Temperature	40°F to 104°F (5°C to 40°C)
-----------------------	------------------------------------

3.5.2 Specifications for FCLC-100 Calibration Fixture

Technical

Product	Calibration Fixture	
Model	FCLC-100	
Frequency Range	10 kHz to 100 MHz	
Standard(s)	IEC 61000-4-6, MIL-STD 461x, RTCA-DO-160x, etc	
Impedance	50Ω (nominal)	
VSWR	0.01-2.5 MHz	≤ 1.01 : 1
	2.5-10 MHz	≤ 1.04 : 1
(empty fixture – no probe installed)	10-30 MHz	≤ 1.1 : 1
	30-100 MHz	≤ 1.4 : 1

Mechanical

Coaxial RF Connectors	(2) N-type (female)
Dimensions (H)x(W)x(L)	6.4" x 7" x 10" (16.3 x 17.8 x 25.5 cm)
Weight (empty fixture)	8 lbs. (3.63 kg)

Dimensional Accommodations for Current Probes

Max. Probe Diameter	5.63" (14.3 cm)
Min. Probe Aperture Diameter	0.79" (2 cm)
Max. Probe Width	2.83" (7.2 cm)

Environmental

Operating Temperature	40°F to 104°F (5°C to 40°C)
-----------------------	------------------------------------

3.6 Product Dimensional Diagrams

3.6.1 Dimensions of CLCI-100 Bulk Current Injection Probe

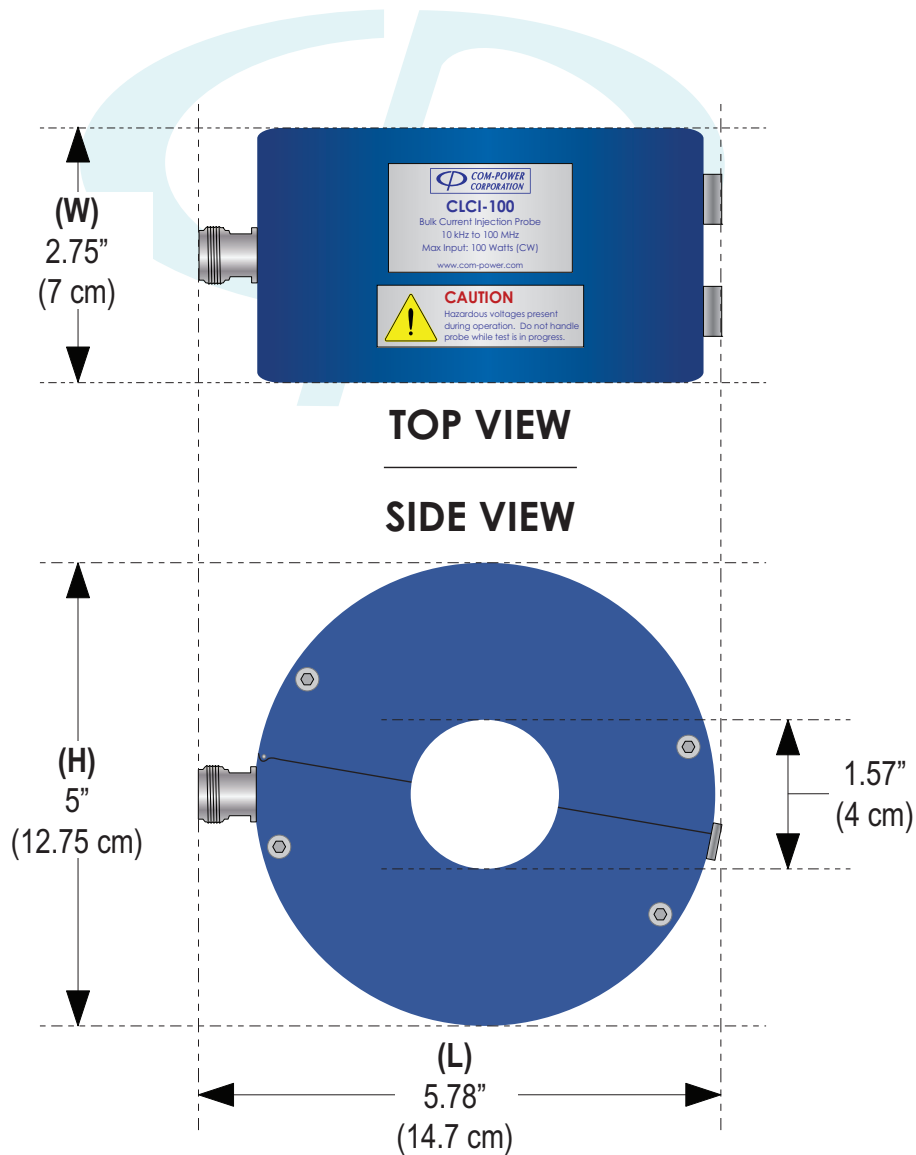

FIGURE 3 - Dimensional Diagram for CLCI-100 Bulk Current Injection Probe

3.6.2 Dimensions of FCLC-100 Calibration Fixture

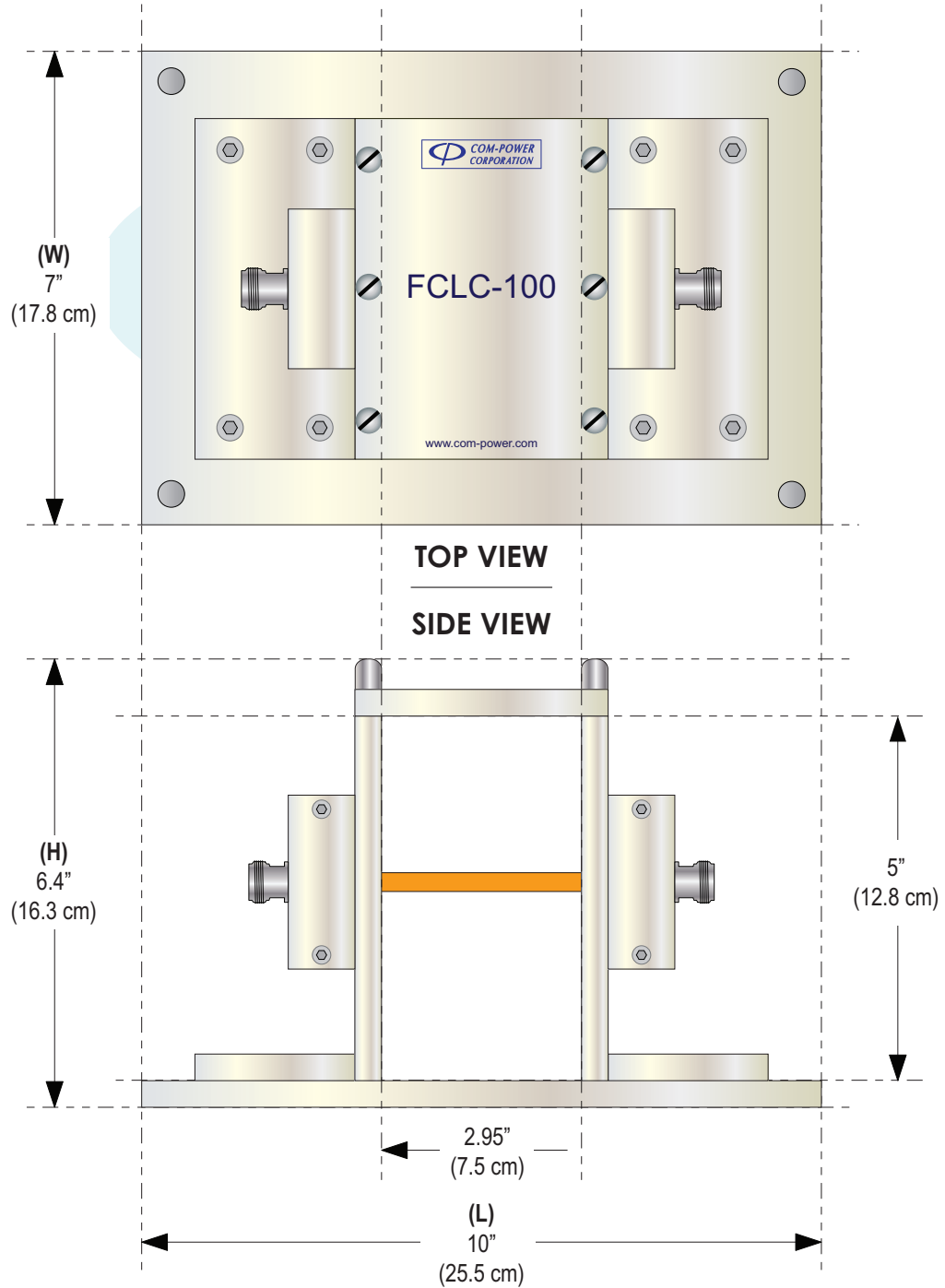

FIGURE 4 - Dimensional Diagram for FCLC-100 Calibration Fixture

4.0 Using the CLCI-100 Probe with the FCLC-100 Fixture

Calibration fixtures provide a means by which current probes, including bulk current injection (BCI) probes, can be calibrated to determine the transfer impedance, insertion/coupling loss. Fixtures are also used to establish, or calibrate, power drive levels into 50Ω or 150Ω systems for various conducted susceptibility/immunity tests performed using BCI probes. These applications are discussed in more detail in the following sections.

The FCLC-100 Fixture is specifically designed for use with the CLCI-100 BCI probe. The intent of the fixture is to maintain the coaxial structure of the transmission line, while allowing the probe to be installed around the center conductor of the coaxial line.

4.1 Installation of CLCI-100 Probe into FCLC-100 Fixture

Illustrated in Figure 5 is the procedure to be followed for installing the CLCI-100 BCI Probe into the FCLC Calibration Fixture.

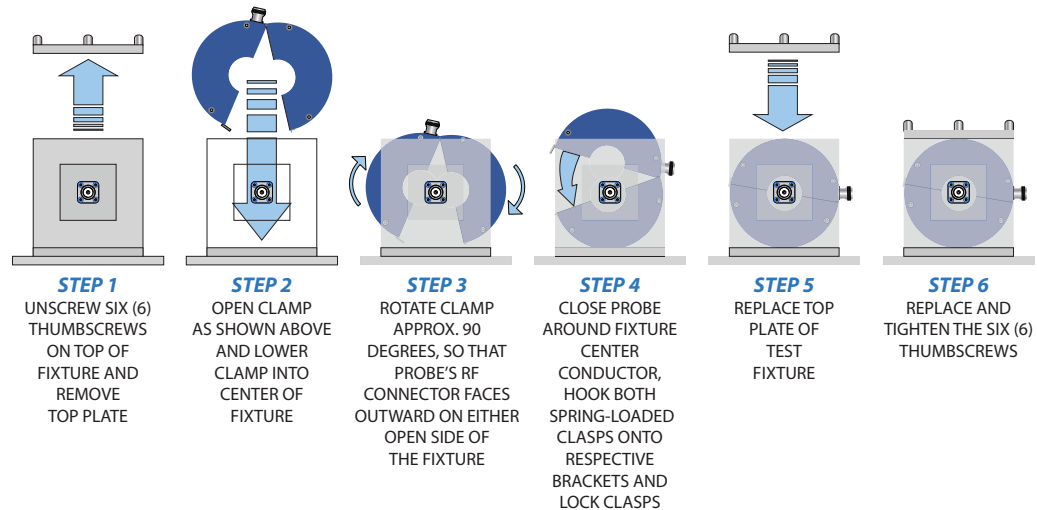

FIGURE 5 - Installation of CLCI-100 Probe into FCLC Calibration Fixture

4.2 Insertion Loss/Coupling Factor Measurement

Illustrated in Figures 6 and 7 are typical setups for the measurement of a current probe's insertion loss, also known as coupling factor. Figure 6 shows the setup for a 50 ohm system (100 ohm loop); and Figure 7 shows the setup for a 150 ohm system (300 ohm loop).

The insertion loss/coupling factor is essentially the difference between the voltage present on the conductor(s) passing through the current probe aperture and the voltage present at the output of the probe. These two quantities are depicted as V_1 and V_2 , respectively, in Figure 8; where $V_2 - V_1 = \text{Insertion Loss/Coupling Factor}$.

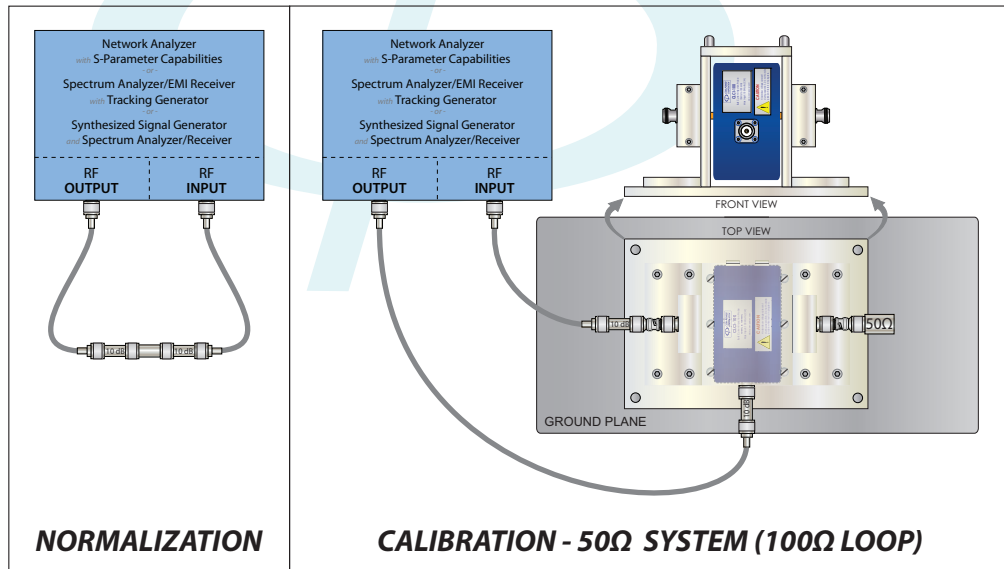

FIGURE 6 - Setup for Insertion/Coupling Loss in a 50Ω System (100Ω Loop)

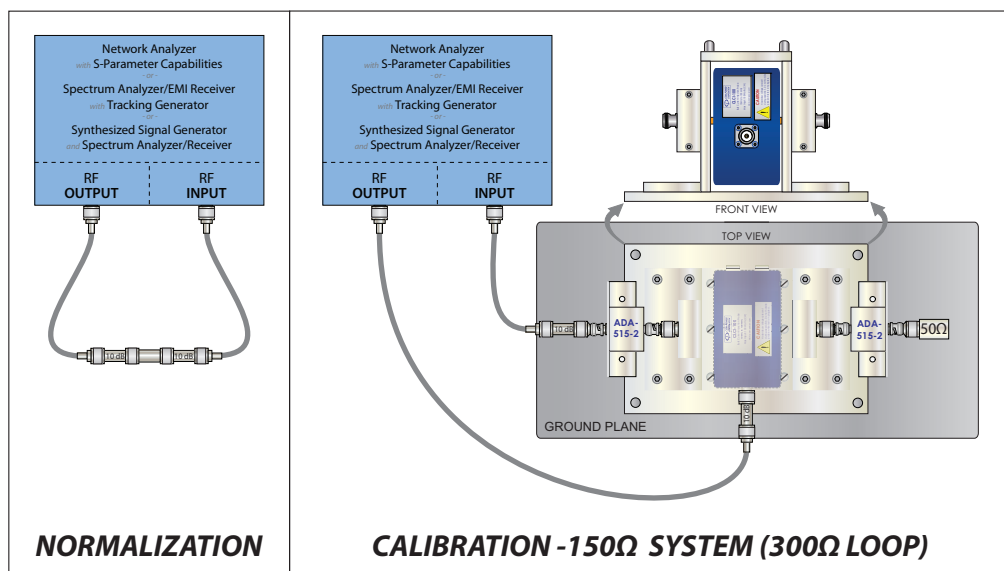

FIGURE 7 - Setup for Insertion/Coupling Loss in a 150Ω System (300Ω Loop)

4.3 Transfer Impedance Factors

When performing current measurements, the conductor(s) under test are passed through the aperture of the current probe. The RF port of the current probe is connected to the 50 ohm RF input of a spectrum analyzer or EMI receiver, where a voltage value is measured.

The transfer impedance factor includes the loss of the probe (see section 4.2), and also converts the measured voltage value to a current value corresponding to the current flowing on the conductor(s) under test.

Illustrated in Figure 8 is a diagram of the equivalent calibration circuit, along with the associated calculations.

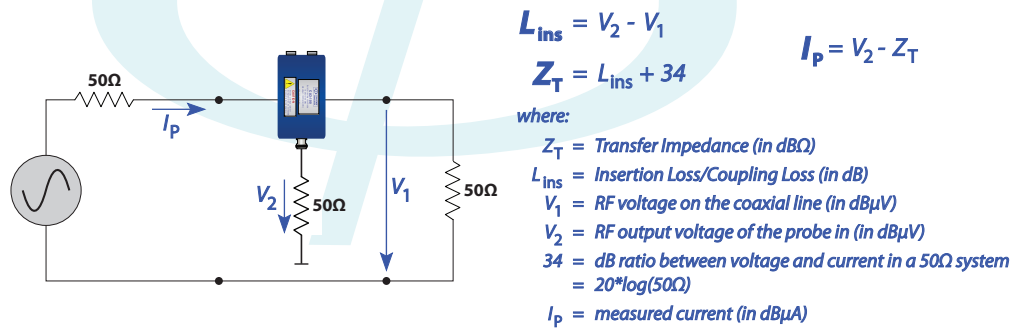

FIGURE 8 - Equivalent Schematic of Calibration Circuit

4.4 Conducted Immunity Test Level Calibration (IEC 61000-4-6)

Calibration of test levels per IEC 61000-4-6 is performed with the **CLCI-100 Bulk Current Injection Probe** installed in the **FCLC-100 Calibration Fixture**. The calibration is performed into a 150 ohm system, rather than the standard 50 ohm system employed by other standards, such as Mil-Std 461 and RTCA DO-160.

To realize a 150 ohm system, **ADA-515-2 150Ω to 50Ω Adapters** are installed on either side of the test fixture.

4.4.1 Test Generator Equipment (Method A vs Method B)

Per the IEC 61000-4-6 standard, there are two acceptable procedures for quantifying the Test Generator power when the appropriate test level is measured during the calibration at any given frequency, so that the same level can be reproduced during the actual testing process. For the purposes of this procedure, we will refer to these as **METHOD A (Signal Generator Output Method)** and **METHOD B (Forward Power Method)**. Illustrated in Figure 9 are example diagrams of the respective test generator systems.

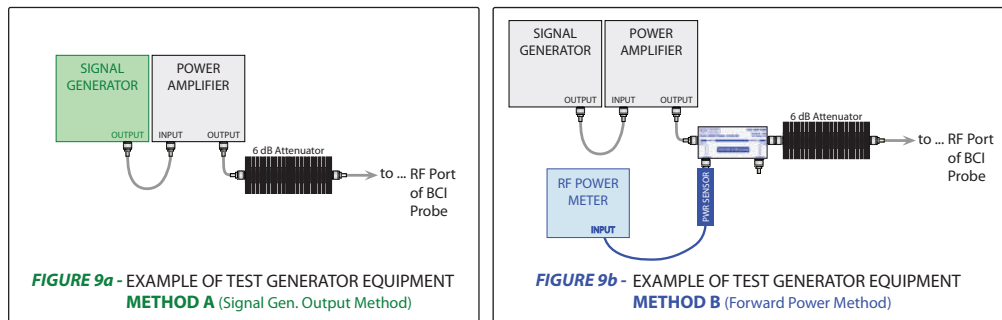

FIGURE 9 - Examples of Test Generator Systems

For each method, the RF power is injected into RF port of the bulk current injection probe, and the amplitude is measured at the output of the 150Ω to 50Ω Adapter (ADA-515-2) connected to one side of the test fixture (through a power attenuator). For each test frequency, the amplitude of the injected RF is adjusted incrementally until the measured amplitude reaches the appropriate level (**U_{mr}**).

Method A: For method A, once the appropriate amplitude is measured during calibration process, the signal generator output level is recorded with respect to the test frequency.

During the test, the signal generator output level at any given test frequency is equal to the respective signal generator output level recorded during the calibration.

Method B: For method B, once the appropriate amplitude is measured during the calibration process, the forward power of the test generator is recorded. The forward power is measured with an RF power meter and power sensor, typically connected to the forward port of a directional coupler installed in series with the RF output of the power amplifier.

During the test, the signal generator output level is adjusted so that the forward power measured on the power meter at any given frequency is equal to the respective forward power level recorded during the calibration.

In the following sections, instructions are included for both methods:

Instructions common for both METHOD A and METHOD B are shown in BLACK text.

Any instructions which apply only for METHOD A are shown in GREEN text.

Any instructions which apply only for METHOD B are shown in BLUE text.

4.4.2 Calibration-related Calculations

The following sets of calculations are indispensable to the proper application of the calibration process. These calculations apply only to calibrations performed per the IEC 61000-4-6 standard. Please refer to the IEC 61000-4-6 standard for further information.

4.4.2.1 Test Level Calculations

Prior to the start of the calibration process, (**U_{mr}**) must be calculated. (**U_{mr}**) represents the voltage to be measured at the output of the ADA-515-2 150Ω to 50Ω Adapter connected to one side of the test fixture, and must not be confused with the open circuit test level (**U_o**) for the calibration (i.e.: 1 Vrms, 3 Vrms, 10 Vrms, etc.) The relationship between (**U_{mr}**) and (**U_o**) is given below:

$$U_{mr} = \frac{U_o}{6} \quad (\text{in linear quantities}) \quad \text{- or -} \quad U_{mr} = U_o - 15.6 \text{ dB} \quad (\text{in logarithmic quantities})$$

So, for instance, if calibration is being performed for a test level of 10 Vrms:

Open Circuit Test Level	Voltage at Output of 150Ω to 50Ω Adapter
$U_o = \begin{matrix} 10 \text{ V}_{rms} \\ 140 \text{ dB}\mu\text{V} \end{matrix}$	$U_{mr} = \begin{matrix} 1.67 \text{ V}_{rms} & (U_{mr} = U_o / 6) \\ 124.5 \text{ dB}\mu\text{V} & (U_{mr} = U_o - 15.6 \text{ dB}) \end{matrix}$

Due to the fact that, in our example, there is a 30 dB attenuator between the output of the 150Ω to 50Ω Adapter and the input of the spectrum analyzer, the (**U_{mr}**) value must also be corrected for the attenuation.

Voltage at Output of 30 dB Attenuator Connected to 150Ω to 50Ω Adapter
$U_{mr-30dB} = \begin{matrix} 0.053 \text{ V}_{rms} \\ 94.5 \text{ dB}\mu\text{V} \end{matrix} \quad (U_{mr-30dB} = U_{mr} - 30 \text{ dB})$

NOTE: Attenuators other than 30 dB may also be used, assuming that any corrections will be adjusted accordingly.

4.4.2.2 Test Level Offset Calculations

If the CLCI-100 Bulk Current Injection Probe will be used for multiple test levels (1 Vrms, 3 Vrms, 10 Vrms, etc.), calibration should be performed at the highest test level. Calibration data for the lower test levels can then be calculated as shown below:

$$U_{\text{offset}} \text{ (in dB)} = 20 \cdot \log \left(\frac{U_{\text{cal}} \text{ (in Vrms)}}{U_{\text{calc}} \text{ (in Vrms)}} \right) \quad \text{- or -} \quad U_{\text{offset}} \text{ (in dB)} = U_{\text{cal}} \text{ (in dB)} - U_{\text{calc}} \text{ (in dB)}$$

where: U_{cal} = calibration test level
 U_{calc} = calculated test level

The offset factor calculated above can then be applied to the calibration data as shown below:

$$SG_{\text{out}_{\text{calc}}} \text{ (in dBxx)} = SG_{\text{out}_{\text{cal}}} \text{ (in dBxx)} - U_{\text{OFFSET}} \text{ (in dB)}$$

$$FWDpwr_{\text{calc}} \text{ (in dBm)} = FWDpwr_{\text{cal}} \text{ (in dBm)} - U_{\text{OFFSET}} \text{ (in dB)}$$

where: $SG_{\text{out}_{\text{calc}}}$ = calculated signal generator output for lower test level
 $SG_{\text{out}_{\text{cal}}}$ = signal generator output determined during calibration at highest test level
 $FWDpwr_{\text{calc}}$ = calculated forward power for lower test level
 $FWDpwr_{\text{cal}}$ = forward power measured during calibration at highest test level

4.4.2.3 Test Frequency Calculations

The frequency range of the test is, in most cases, 150 kHz to 80 MHz; and, in some cases, 150 kHz to 230 MHz. The calibration and test is performed at discrete, logarithmically spaced frequencies (as opposed to a frequency sweep). The logarithmic spacing of the test frequencies means that the actual step size increases after each step. The maximum step size at any given frequency is equal to 1% of the present frequency. Below is a truncated example of the test frequencies, showing the respective step sizes.

TEST FREQUENCY (MHz)	STEP SIZE (Hz)	TEST FREQUENCY (MHz)	STEP SIZE (Hz)	TEST FREQUENCY (MHz)	STEP SIZE (Hz)	TEST FREQUENCY (MHz)	STEP SIZE (Hz)	TEST FREQUENCY (MHz)	STEP SIZE (Hz)	
1	0.15	1.5		21	0.18328506	1.8328506		31	0.202177337	2.02177337
2	0.1514	1.514		22	0.18485871	1.8485871		32	0.204199111	2.041991102
3	0.153015	1.53015		23	0.186707379	1.86707379		33	0.206241102	2.062411018
4	0.15454515	1.5454515		24	0.188574453	1.885744528		34	0.208303513	2.083035128
5	0.156090602	1.560906015		25	0.190460197	1.904601973		35	0.210386548	2.103865479
6	0.157651508	1.576515075		26	0.192364799	1.923647973		36	0.212494819	2.124904154
7	0.159228024	1.592280224		27	0.194288447	1.942884472		37	0.214615318	2.144153175
8	0.160820503	1.608205028		28	0.196231332	1.962313317		38	0.2167471471	2.167614707
9	0.162428504	1.624285058		29	0.198193645	1.981936445		39	0.218892085	2.189290854
10	0.164052791	1.640527909		30	0.200175581	2.001755815		40	0.221118374	2.211183743
								41	0.223329258	2.23329258
								42	0.225528564	2.25528564
								43	0.227716484	2.277164842
								44	0.230096660	2.30096660
								45	0.232397636	2.323976357
								46	0.234721810	2.347218121
								47	0.237068976	2.37068976
								48	0.239439516	2.394395165
								49	0.241833912	2.418339112
								50	0.244252251	2.442522508

Step Size = Present Frequency * 0.01

Next Test Frequency = Present Frequency + (Present Frequency * 0.01)

4.4.3 Equipment Setup

On a conductive ground plane, connect the FLC-100 Calibration Fixture with the CLCI-100 Bulk Current Injection Probe installed to the Calibration Accessories, Adapters and Attenuators as shown in Figures 10. The bottom surface of test fixture should be flush against the top surface of the ground plane, and should either be: bolted directly to the ground plane (through their respective mounting holes); or should be bonded to the ground plane using copper tape with conducted adhesive (3M #1181 HD recommended).

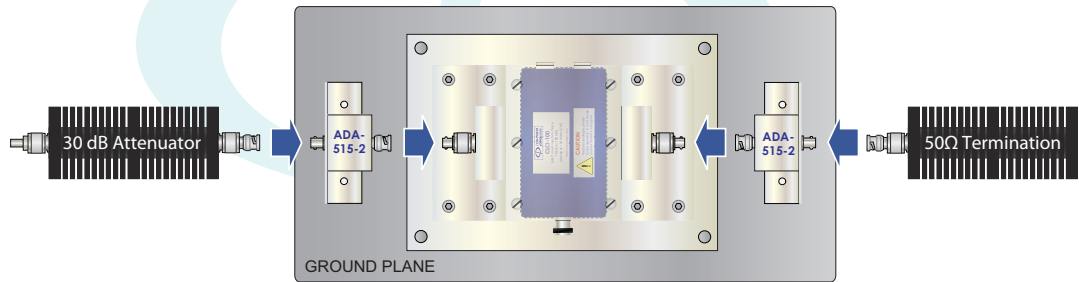

FIGURE 10 - Setup for Calibration Accessories for 150Ω System

As shown in **Figure 11 (for METHOD A)**; or, as shown in **Figure 12 (for METHOD B)**, as appropriate, complete the calibration setup.

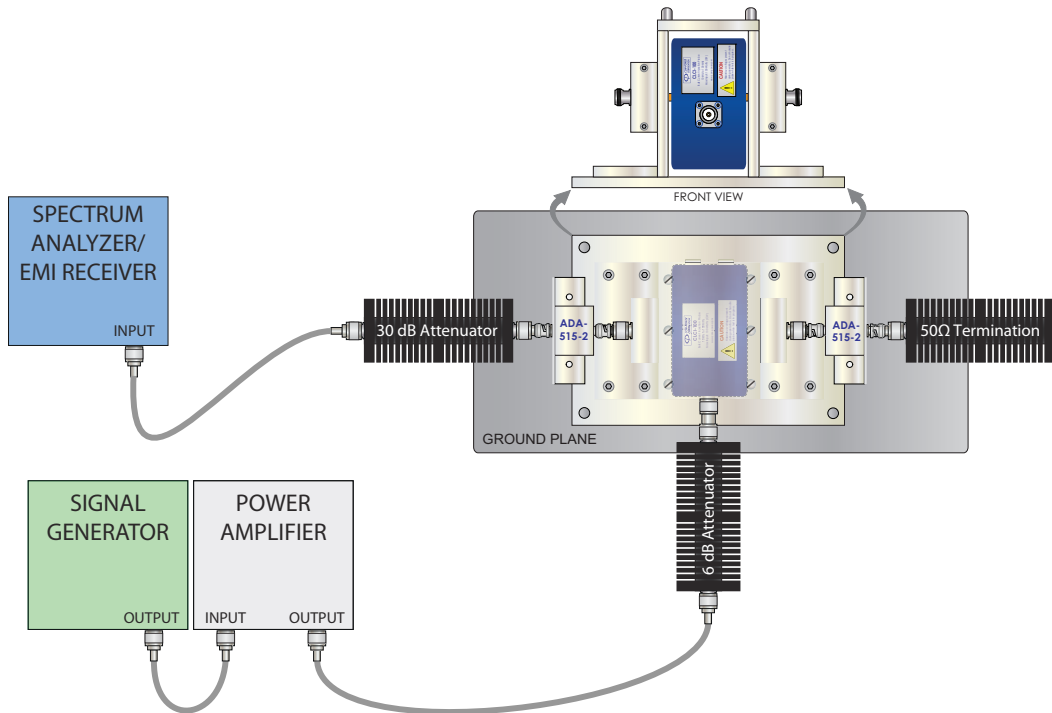

FIGURE 11 - IEC 61000-4-6 (Method A) Test Level Calibration Setup

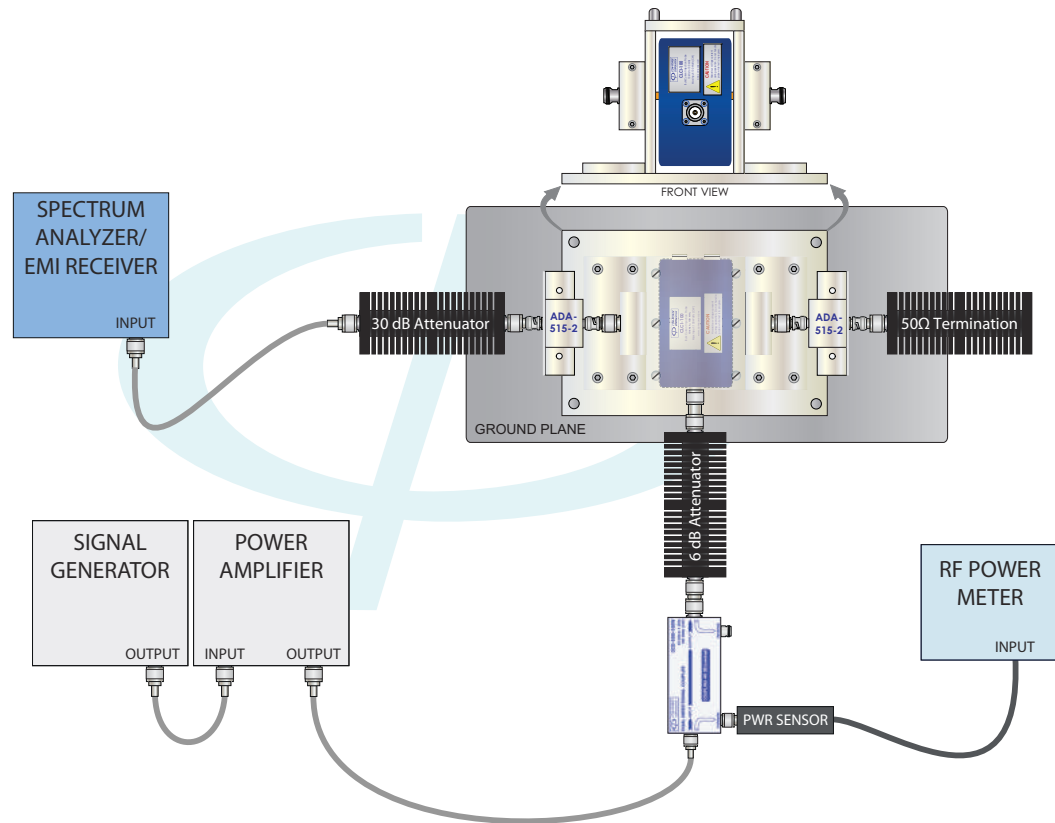

FIGURE 12 - IEC 61000-4-6 (Method B) Test Level Calibration Setup

4.4.4 Level Setting Process

- 1) With the calibration test setup configured as shown in **Figure 11** or **Figure 12**, set the frequency of the signal generator to 150 kHz (without modulation).
- 2) WITHOUT exceeding [the 1 dB gain compression point of the power amplifier minus 5.1 dB], adjust the amplitude setting of the signal generator until the amplitude measured on the spectrum analyzer is equal to the (**U_{mr-30dB}**) value (± 1.5 dB) calculated for the open circuit test level (**U_o**) for which calibration is being performed (see section 4.4.2.1).
- 3) **Record either:**
 - (a) the frequency (fx) and amplitude setting of the signal generator (SGout)

-or-

 - (b) the frequency (fx) and forward power measured using the power meter/sensor (FWDpwr).

See examples of calibration data tables on the right.

CALIBRATION DATA TABLE EXAMPLES

#	TEST FREQ (fx) (MHz)	SIGNAL GEN OUTPUT SGout (dBxx)
1	0.15	xx.xx
2	0.1515	xx.xx
3	0.153015	xx.xx
...
633 or 739	80 or 230	xx.xx

#	TEST FREQ (fx) (MHz)	FORWARD POWER FWDpwr (dBxx)
1	0.15	xx.xx
2	0.1515	xx.xx
3	0.153015	xx.xx
...
633 or 739	80 or 230	xx.xx

- 4) Increase the frequency by a maximum of 1% of the present frequency (see section 4.4.2.3).
- 5) Repeat steps (2) through (4) until the next frequency in the sequence would exceed the highest frequency of the test. For tests up to 80 MHz, there should be at least 633 test frequencies; and for tests up to 230 MHz, there should be at least 739 test frequencies.

4.4.5 Amplifier Saturation Check

- 1) With the calibration test setup configured as shown in **Figure 11** or **Figure 12**, set the frequency of the signal generator to 150 kHz (without modulation).
- 2) **Adjust the signal generator output to either:**
 - a) the respective SG_{out} value determined during calibration for the present test frequency;
 - or-
 - b) the level at which the power indicated by the power meter is equal to the respective FWD_{pwr} value determined during calibration for the present test frequency.
- 3) Record the amplitude measured on the spectrum analyzer as (U_{mr}).
- 4) Increase the signal generator output by 5.1 dB, and record the amplitude measured on the spectrum analyzer as ($U_{mr(inc)}$). The difference between (U_{mr}) and $U_{mr(inc)}$ must be between 3.1 dB and 7.1 dB.
- 5) Increase the frequency of the signal generator to the next test frequency.
- 6) Repeat steps (2) through (5) until the next frequency in the sequence would exceed the highest frequency of the test.

4.4.6 Running the Test

Examples of the test setup are shown in **Figure 13 (for METHOD A)** and **Figure 14 (for METHOD B)**.

The same Test Generator equipment used for the calibration is used to inject the RF energy onto the EUT lines under test via the CLCI-100 Bulk Current Injection probe. The calibration data table is used to set the signal generator output at any given frequency to either:

- a) the respective S_{Gout} value determined during calibration for the present test frequency; or,
- or-
- b) the level at which the power indicated by the power meter is equal to the respective FWD_{pwr} value determined during calibration for the present test frequency.

Typically, the test is performed from the lowest test frequency to the highest test frequency, one test frequency at a time, with a one to three second dwell time at each test frequency. The RF carrier is typically 80% amplitude modulated with a 1 kHz sine wave.

As the calibration is performed into a 150 ohm system, and the impedance of the line(s) under test is largely uncontrolled, the injected current must be monitored during the test using a current monitoring device to ensure that the current does not exceed the (I_{max}) limit:

$$I_{max} = \frac{U_o}{150\Omega}$$

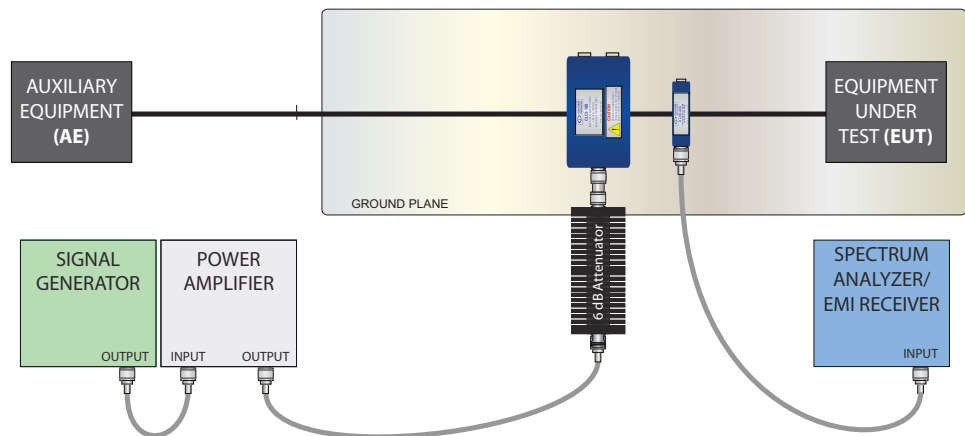

FIGURE 13 - IEC 61000-4-6 (Method A) Test Setup

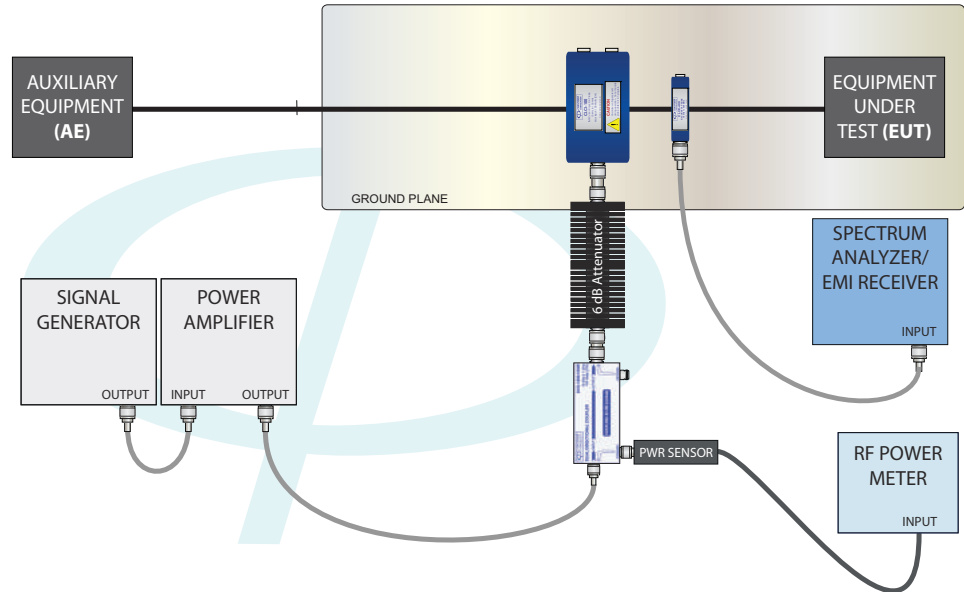

FIGURE 14 - IEC 61000-4-6 (Method B) Test Setup

4.5 Conducted Susceptibility Test Level Calibration (50Ω System)

Illustrated in Figure 15 is a typical test setup for test level calibrations performed into a 50 ohm system. This calibration is typically employed for tests according to Mil-Std 461, RTCA DO-160, and other standards.

Please refer to the applicable standards for guidance on the performance of these calibrations/tests.

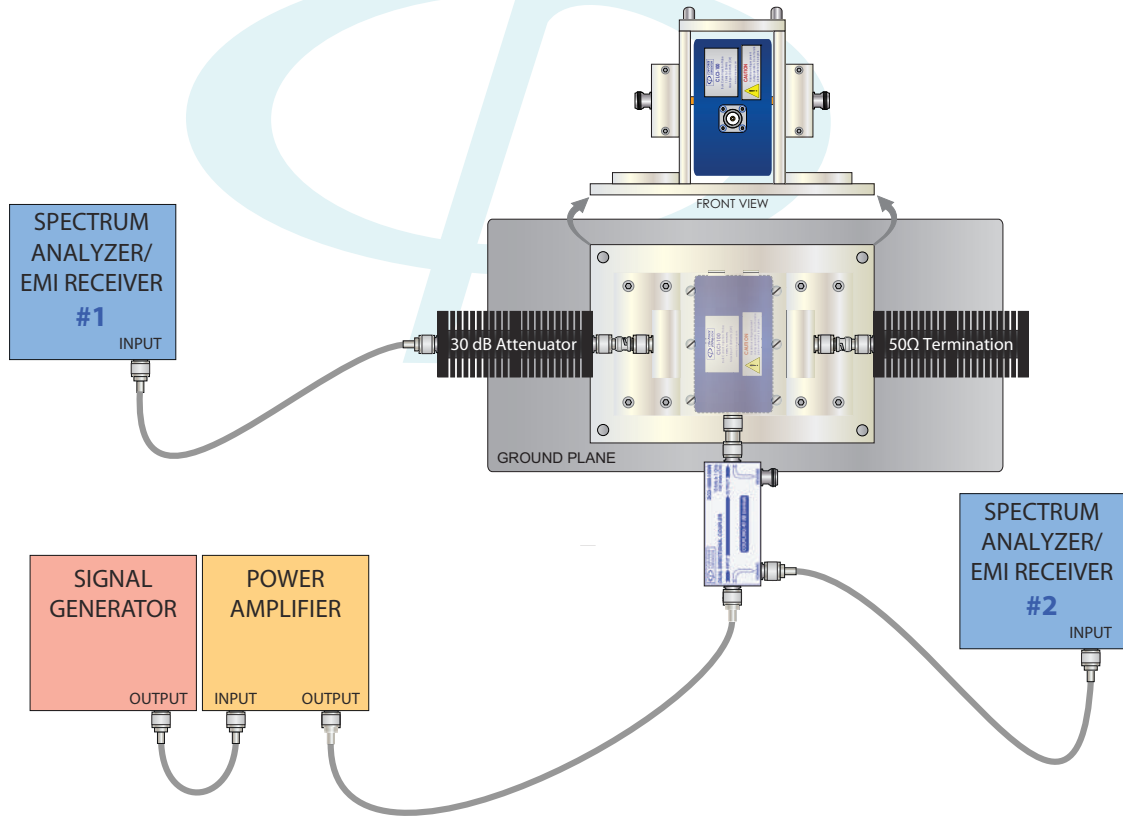

FIGURE 15 - Test Level Calibration into 50 ohm System

5.0 Warranty

Com-Power warrants to its Customers that the products it manufactures will be free from defects in materials and workmanship for a period of three (3) years. This warranty shall not apply to:

- Transport damages during shipment from your plant.
- Damages due to poor packaging.
- Products operated outside their specifications.
- Products Improperly maintained or modified.
- Consumable items such as fuses, power cords, cables, etc.
- Normal wear
- Calibration
- Products transported outside the United States without the prior knowledge of Com-Power.

In addition, Com-Power shall not be obliged to provide service under this warranty to repair damage resulting from attempts to install, repair, service or modify the instrument by personnel other than Com-Power service representatives.

Under no circumstances does Com-Power recognize or assume liability for any loss, damage or expense arising, either directly or indirectly, from the use or handling of this product, or any inability to use this product separately or in combination with any other equipment.

When requesting warranty services, it is recommended that the original packaging material be used for shipping. Damage due to improper packaging will void warranty.

In the case of repair or complaint, Please visit our website www.com-power.com and fill out the RMA form (<http://com-power.com/repairservicereq.asp>). Our technical assistance personnel will contact you with RMA number. The RMA number should be displayed in a prominent location on the packaging and on the product, along with a description of the problem, and your contact information.

6.0 Typical CLCI-100 Calibration Data

