

SELECTION TABLES OF TEMPERATURE, HUMIDITY, PRESSURE CO₂ TRANSMITTERS Txxxx, Pxxxx

INDUSTRIAL TRANSMITTERS of Txxxx, Pxxxx family:

MEASURED VALUE / OUTPUT	4 to 20mA	0 to 10V	RS485	RS232	Ethernet
temperature	P0120 figure 2 page 42	T4211 figure 3 page 47	T0410 figure 4 page 49	T0310 figure 4 page 51	P86xx figure 2 page 53
	Px1x1 figure 1 page 42		T4411 figure 3 page 49	T4311 figure 3 page 51	P85xx figure 2 page 55
	T0110 figure 4 page 43				T0510 figure 4 page 57
	T4111 figure 3 page 43				T4511 figure 3 page 59
humidity	T1110 figure 5 page 43				
atmospheric pressure	T2114 figure 3 page 45	T2214 figure 3 page 45	T2414 figure 3 page 49	T2314 figure 3 page 51	T2514 figure 3 page 59
temperature+humidity	T3110 figure 5 page 43	T0210 figure 5 page 47	T3411 figure 5 page 49	T3311 figure 5 page 51	T3510 figure 5 page 57
	T3113 figure 6 page 43	T0213 figure 6 page 47	T3413 figure 6 page 49	T3313 figure 6 page 51	T3511 figure 8 page 59
	T3117 figure 7 page 43	T0211 figure 8 page 47	T3417 figure 7 page 49	T3319 figure 8 page 51	
	T3111 figure 8 page 43		T3419 figure 8 page 49		
temperature+humidity +atmospheric pressure			T7410 figure 5 page 49	T7310 figure 5 page 51	
CO ₂	T5140 figure 3 page 46	T5240 figure 3 page 47	T5440 figure 3 page 49	T5340 figure 3 page 51	T5540 figure 3 page 57
	T5141 figure 8 page 46	T5241 figure 8 page 47	T5441 figure 8 page 49	T5341 figure 8 page 51	T5541 figure 8 page 59
temperature+humidity+ CO ₂			T6440 figure 5 page 49	T6340 figure 5 page 51	T6540 figure 5 page 57

Pxxxx, Txxxx

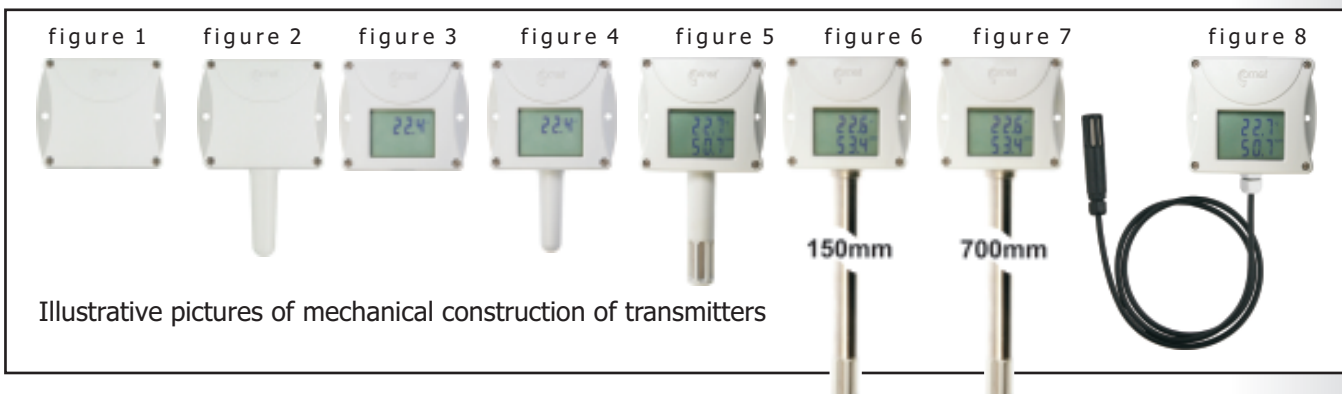

INTERIOR TRANSMITTERS of Txx18 family

MEASURED VALUE / OUTPUT	4 to 20mA page 63	0 to 10V page 63	RS485 page 65	RS232 page 65
temperature	T0118	T0218	T0418	T0318
atmospheric pressure	T2118	T2218		
temperature + humidity	T3118	T3218	T3418	T3318
temperature + humidity + atmospheric pressure			T7418	T7318



TECHNICAL PARAMETERS OF TRANSMITTERS T3118, T3218

Measuring range of relative humidity:	5 to 95%
Accuracy of relative humidity measurement:	$\pm 2.5\%$ RH from 5 to 60%RH, $\pm 3.0\%$ RH from 60 to 95%RH at 23°C
Accuracy and range of temperature measurement:	$\pm 0.5^\circ\text{C}$ from 0 to $+50^\circ\text{C}$, switchable to degrees Fahrenheit
Accuracy and range of dew point temperature:	$\pm 1.6^\circ\text{C}$ at ambient temperature $< 25^\circ\text{C}$ and RH $>30\%$, range -60 to $+80^\circ\text{C}$
Accuracy and range of absolute humidity:	$\pm 3\text{g/m}^3$ at ambient temperature $T < 40^\circ\text{C}$, range 0 to 400 g/m^3
Accuracy and range of specific humidity:	$\pm 2\text{g/kg}$ at ambient temperature $T < 35^\circ\text{C}$, range 0 to 550 g/kg
Accuracy and range of mixing ratio:	$\pm 2.2\text{g/kg}$ at ambient temperature $T < 35^\circ\text{C}$, range 0 to 995 g/kg
Accuracy and range of specific enthalpy:	$\pm 3.5\text{kJ/kg}$ at ambient temperature $T < 25^\circ\text{C}$, range 0 to 995 kJ/kg

Any measured value - temperature, relative humidity, dew point temperature, absolute humidity, specific humidity, mixing ratio or specific enthalpy can be assigned to any of the two outputs of T3118 or T3218 transmitter. Also identical value can be assigned to both outputs. Outputs are adjusted to maximum range from the manufacturer (0 to 50°C , 0 to 100%RH). Output range is user adjustable from the PC by means of the optional cable SP003 - see below.

Free configuration program TSensor for transmitter adjustment is ready to download anytime.

If different adjustment of outputs and output ranges are required, please specify required output values (RH, T, Tdp, ..) and required ranges.

Barometer T2118 or T2218 enables to measure sea level pressure by setting of correction to altitude above sea level.

Ordering example: Transmitter T3118, output 1: RH 10 to 90%, output 2: temperature 0 to 35°C

Interior sensors

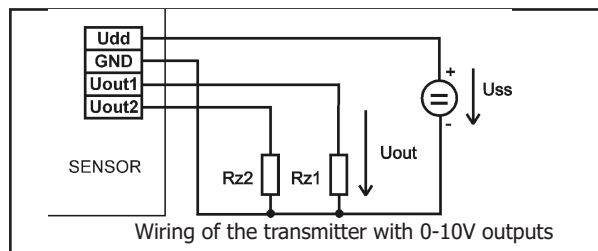
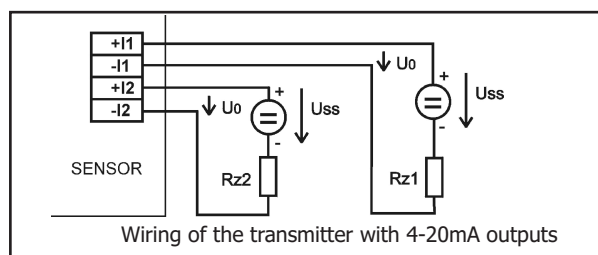
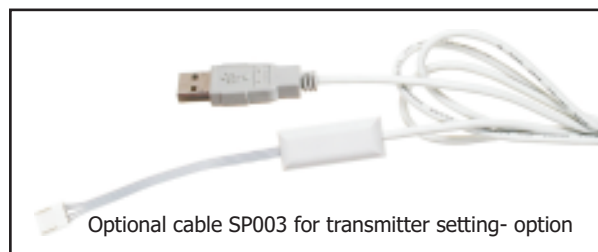
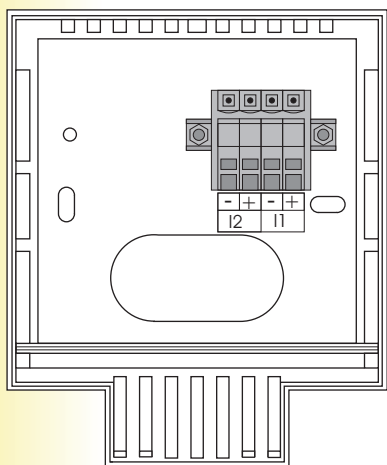
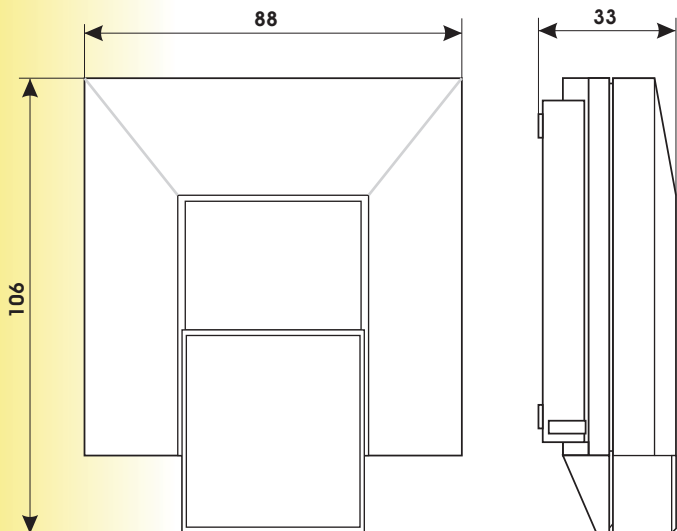

Included accessory:

Traceable calibration certificate from the manufacturer, instruction manual. Calibration certificate with declared metrological traceability of etalons is based on requirements of EN ISO/IEC 17025 standard.

Free program TSensor for configuring of the transmitter is ready to be downloaded from www.cometsystem.cz.

Transmitters are directly compatible with sixteen channel Comet data acquisition system MSx.

INTERIOR TEMPERATURE, HUMIDITY, PRESSURE TRANSMITTERS with serial RS485, RS232 output

temperature*barometric pressure*relative humidity*dew point temperature* absolute humidity*specific humidity*mixing ratio*specific enthalpy

APPLICATIONS - measuring of temperature, humidity and pressure at:

- residential and official buildings
- building energy management and HVAC systems
- pharmaceutical industry
- museums, archives, galleries
- wireless data acquisition via GSM

Temperature, humidity, barometric pressure transmitters are specially designed for use in exacting interiors in building energy management and HVAC systems. Are designed for easy installation on ordinary KU68 wiring boxes for household switches and sockets.

Large dual line LCD for display of temperature, humidity, barometric pressure or other computed value is an advantage. Display is possible to switch off. Computerized design ensures temperature compensation of the humidity and pressure sensors and fail indication.

Measured value is converted to digital serial output with the RS485 or RS232 link parameters. The RS485 transmitter circuitry is galvanically isolated from power circuitry to prevent collision in RS485 network. The transmitter works with ModBus RTU communication protocol or with Advantech ADAM compatible protocol.

Serial link enables to read actual readings and modify transmitter configuration. Wireless data acquisition system via GSM can be built easily with Comet software package Database Sensor Monitor.



TECHNICAL PARAMETERS

Operating temperature range:	0 to +50°C
Accuracy and range of temperature measurement:	±0.5°C from 0 to +50°C, switchable to degrees Fahrenheit
Measuring range of relative humidity:	5 to 95%RH
Accuracy of relative humidity measurement:	±2.5% RH from 5 to 60%RH, ±3.0% RH from 60 to 95%RH at 23°C
Accuracy and range of dew point temperature:	±1.6°C at ambient temperature < 25°C and RH>30%,range -60 to +80°C
Accuracy and range of absolute humidity:	±3g/m³ at ambient temperature T < 40°C, range 0 to 400 g/m³
Accuracy and range of specific humidity:	±2g/kg at ambient temperature T < 35°C, range 0 to 550 g/kg
Accuracy and range of mixing ratio:	±2.2g/kg at ambient temperature T < 35°C, range 0 to 995 g/kg
Accuracy and range of specific enthalpy:	± 3.5kJ/kg at ambient temperature T < 25°C, range 0 to 995 kJ/kg
Accuracy and range of barometric pressure:	± 1,3hPa at 23°C, range: 600 to 1100 hPa
Communication protocols:	ModBus RTU, ADAM Advantech, HW group
Communication speed:	110 to 115200 Bd
Power:	9-30Vdc, consumption with RS485 approximately 0,5W,with RS232 6mA
Dimensions (W x H x D):	88 x 106 x 33mm
Protection:	IP20
Material of the case:	ABS, white
Warranty:	two years

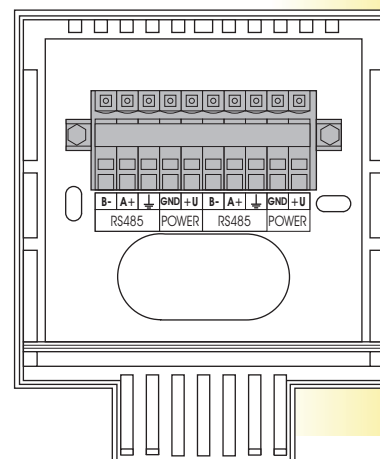
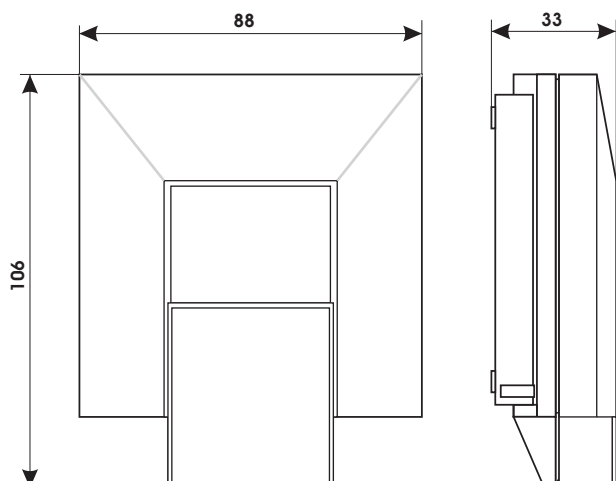

temperature*barometric pressure*relative humidity*dew point temperature*
absolute humidity*specific humidity*mixing ratio*specific enthalpy

TRANSMITTERS WITH RS485 OUTPUT

- communication circuitry is GALVANICALLY ISOLATED from power circuitry to prevent collision in RS485 network

TYPE	MEASURED VALUE	DESCRIPTION
T0418	temperature	Air temperature transmitter. Display reading and temperature output is user selectable in degrees Celsius or Fahrenheit.
T3418	temperature humidity	Air temperature and humidity transmitter. Measured temperature and relative humidity are converted to other humidity interpretation - dew point temperature, absolute humidity, specific humidity, mixing ratio or specific enthalpy. Air temperature, humidity, pressure transmitter.
T7418	temperature humidity atmospheric pressure	Measured temperature and relative humidity are converted to other humidity interpretation - dew point temperature, absolute humidity, specific humidity, mixing ratio or specific enthalpy. Display reading and pressure output is user selectable in these units: hPa, kPa, mbar, mmHg, inHg, inH ₂ O, PSI, oz/in ² Barometer enables to measure sea level pressure by setting of correction to altitude above sea level.

TRANSMITTERS WITH RS232 OUTPUT

- communication circuitry is GALVANICALLY CONNECTED to power circuitry

TYPE	MEASURED VALUE	DESCRIPTION
T0318	temperature	Air temperature transmitter. Display reading and temperature output is user selectable in degrees Celsius or Fahrenheit.
T3318	temperature humidity	Air temperature and humidity transmitter. Measured temperature and relative humidity are converted to other humidity interpretation - dew point temperature, absolute humidity, specific humidity, mixing ratio or specific enthalpy.
T7318	temperature humidity atmospheric pressure	Air temperature, humidity, pressure transmitter. Measured temperature and relative humidity are converted to other humidity interpretation - dew point temperature, absolute humidity, specific humidity, mixing ratio or specific enthalpy. Display reading and pressure output is user selectable in these units: hPa, kPa, mbar, mmHg, inHg, inH ₂ O, PSI, oz/in ² Barometer enables to measure sea level pressure by setting of correction to altitude above sea level.

Included accessory:

Traceable calibration certificate from the manufacturer, instruction manual. Calibration certificate with declared metrological traceability of etalons is based on requirements of EN ISO/IEC 17025 standard.

Free program TSensor for configuring of the transmitter is ready to be downloaded from www.cometsystem.cz.







Free program SensorReader for logging values from one thermometer to a PC disk file is ready to download. Recorded values in CSV format are easy to process in e.g. Excel.

For acquiring values from several transmitters, third party software is possible to use. Tested functionality is with programs LabVIEW from National Instruments, TIRS.NET, ControlWeb, EasyView.

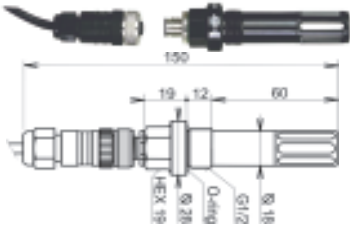



Optional accessory:

Transmitters Tx418 with RS485 output are directly compatible with sixteen channel Comet data logger MS.

OPTIONAL ACCESSORIES FOR HUMIDITY TRANSMITTERS

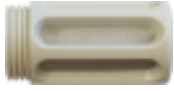
<p>New - probe for compressed air</p>	<p>Order code</p>	
	<p>TxxxxP Hxxxx1P</p>	<p>Optional temperature, humidity, dew-point probe designed for compressed air measurement up to 25 bars. Cable lengths 1, 2 or 4m available. Length 110mm, diameter 18mm, G1/2 thread. Available with TxxxxP, HxxxxP transmitters.</p>
	<p>SH-PP</p>	<p>Flow chamber for compressed air measurement up to 25 bars - stainless steel DIN 1.430. Inlet and outlet connection - G1/8 thread. Humidity probe connection - G1/2 thread. Screw-coupling not included.</p>
	<p>TxxxxL HxxxxL</p>	<p>Transmitter version with watertight male connector IP67 Lumberg RSFM4 instead of cable gland for easy connection/disconnection of the output. Specify please your order with letter L behind model code - e.g. T3110L or H3020L</p>
	<p>K1427</p>	<p>Female connector ELKA 4012PG7 for TxxxxL, HxxxxL transmitters with male connector Lumberg for easy connection/disconnection of the output. Cable is easily connected to screw terminals of the connector. IP67 protection.</p>
	<p>without LCD</p>	<p>Transmitter version with blind lid without LCD. Specify please the requirement in your order.</p>
	<p>OEM</p>	<p>Transmitters are also available without Comet logo as OEM products. Specify please the requirement in your order. Minimum order of OEM transmitters without Comet logo is 100 pcs.</p>
	<p>F8000</p>	<p>Solar radiation shield for transmitters with T+RH probe on a cable.</p>

OPTIONAL ACCESSORIES FOR HUMIDITY TRANSMITTERS

	Order code	
	F5200	grey sensor cover with filter from stainless steel mesh, filtering ability 0,025mm
	F5200B	black sensor cover with filter from stainless steel mesh, filtering ability 0,025mm
	SP003	Cable for transmitter adjustment via USB port - for models Tx1xx, Tx2xx with analog outputs and models Hx0xx.
	PP4	flat plastic circular flange for duct mounting
	PP90	right-angled stain-less steel flange for wall mounting
	SP004	plastic gland for direct mounting of the humidity probe to a 29 mm diameter hole
	SP005	tool for easy wire connection to WAGO terminals Wago - for transmitters with current and voltage output
	SP006	tool for easy wire connection to WAGO terminals Wago - for Txxxx transmitters with serial output RS485 and RS232 and Hxxxx transmitters
	MD036	self adhesive Dual Lock for easy installation
	A1515	ac/dc adapter 230V-50Hz/12Vdc for Ethernet transmitters Tx5xx, Hx5xx - with co-axial connector
	A1510	ac/dc adapter 230V-50Hz/12Vdc for serial output Txxxx transmitters and Hxxxx transmitters - for connection to terminals
	MD046 HM023 HM024	ACCESSORIES FOR EASY RELATIVE HUMIDITY CALIBRATION AND ADJUSTMENT anodized duraluminum vessel for relative humidity calibration and adjustment set of 5 humidity standards 10% RH with 5 application pads set of 5 humidity standards 80% RH with 5 application pads