



Instruction Manual

T3111

T3111L

T3111P

T3111Ex

Programmable transmitter of temperature, relative humidity and other calculated humidity values with external probe and 4 - 20 mA outputs

© Copyright: COMET System, Ltd.

It is prohibited to copy and make any changes in this manual, without explicit agreement of company COMET System, Ltd. All rights reserved.

COMET System, Ltd. makes constant development and improvement of their products. Manufacturer reserves the right to make technical changes to the device without previous notice. Misprints reserved.

Manufacturer is not responsible for damages caused by using the device in conflict with this manual.

To damages caused by using the device in conflict with this manual can not be provide free repairs during the warranty period.

Read carefully instruction manual before the first device connection.

Table of contents

GENERAL DESCRIPTION	4
T3111EX TRANSMITTER	5
FACTORY SETTINGS	6
DEVICE INSTALLATION	7
INFO MODE	8
MODIFICATION OF DEVICE ADJUSTMENT	9
ERROR STATES OF THE DEVICE	10
TECHNICAL SUPPORT AND SERVICE	11
TECHNICAL DATA	12
MEASURED VALUES	12
CALCULATED HUMIDITY VALUES	13
GENERAL	14
OPERATING CONDITIONS	16
END OF OPERATION	16
DIMENSIONS.....	17
TYPICAL APPLICATION WIRING	19
APPENDIX A	21

General description

The transmitters T3111 are designed for measurement of ambient temperature and relative humidity of air without aggressive substances. Measured values are converted to other humidity interpretation: dew point temperature, absolute humidity, specific humidity, mixing ratio and specific enthalpy. The transmitters are equipped with an external humidity and temperature probe on a cable.

Measured and computed values are displayed on a two-line LCD display. The first line displays temperature (°C / °F). Value displayed on the second line is selectable among relative humidity and computed value. It is also possible to display both readings with cyclic overwriting (4 seconds interval) or to switch off the LCD display at all.

The transmitter communicates by means two galvanically separated current loop 4-20mA. Each loop has two-wire connection and each loop requires power from evaluation device. It is always necessary to connect loop I1 which is designed for supplying of measuring part of the device. Using the configuration software can be assigned to each current loop any measured or computed value.

All transmitter setting is performed by means of the PC connected via the optional SP003 communication cable (not included in delivery). Using TSensor software (see www.cometsystem.cz) you can assign to each output any measured or computed value and to set its measuring range. It is also possible to assign both outputs to the same value (with the same range), if two evaluation devices are necessary to connect. The program supports make the adjustment of the device too. This procedure is described at file „*Calibration manual.pdf*“ which is installed commonly with the software.

Device versions:

T3111	transmitter with cable gland for output cable connection
T3111L	device version with watertight male connector instead of a cable gland for easy connection/disconnection of the output cable (protection IP67)
T3111P	transmitter for measuring the moisture of compressed air with pressure up to 25 bar
T3111Ex	intrinsically safe transmitter for use in potentially explosive environments
T3111Z	this marking is intended for a non-standard versions of the transmitters. Description is not included in this manual.

T3111Ex transmitter

Transmitter T3111Ex is designed and certified for use in hazardous areas. In compliance with European Directive 94/9/EC (ATEX 100a) the T3111Ex transmitter conforms to European Standards EN 60079-0:2012 and EN 60079-11:2012.

Transmitter is suitable for use in potentially explosive atmospheres (Apparatus Groups IIC) in applications requiring devices category 3G.

Type Examination Certificate number FTZÚ 13 ATEX 0189X is available at www.cometsystem.cz.

Factory settings

If special setting was not required in the order device is set from the manufacturer to the following parameters:

value at output I1:	relative humidity range 4-20 mA corresponds 0 to 100 %RH
value at output I2:	temperature range 4-20 mA corresponds -30 to +105 °C
display:	switched ON
temperature unit:	°C
value displayed at line 2:	relative humidity

Device installation

The housing with electronics is designed for wall mounting with two screws or bolts. The mounting position of the housing with electronics and of the probe is arbitrary. To measure temperature and humidity of compressed air (T3111P) is suitable to use the flow chamber SH-PP (see Appendix A).

The connecting terminals are accessible after unscrewing the four screws in the corners of the case and removing the lid. Pass the connecting cable through released gland and connect the wires to terminals (see “*Typical application wiring*”). Tighten the gland and screw the lid (check the integrity of the seal). The female connector for connecting T3111L transmitter connect according to diagram at “*Typical application wiring*”.

For device connection it is recommended to use a shielded cable with a maximum length of 1200m. External diameter of the cable for T3111, T3111P and T3111Ex connection is 4 to 8 mm. For T3311L connection use cable with respect to female connector parameters (do not connect shielding at connector side). When selecting the type of a cable for T3111Ex connection and when choosing a location for T3111Ex mounting it is necessary to observe the conditions for safe installation in potentially explosive environments. The cables should be located as far as possible from potential interference sources.

It is not recommended to use the device for long time under condensation conditions or water aerosol conditions. It could be the cause of water steam condensation inside the sensor’s cover with a consequential increase of response time to humidity changes. It can cause sensor damage too. If this effect may occur, it is necessary to use the probe at operation position with sensor cover downwards.

Devices don’t require special operation and maintenance. It is recommend to keep clean sensor cover and periodically to verify the accuracy of measurement.

Warning

- Installation, commissioning and maintenance may only be carried out by personnel with qualification by applicable regulations and standards.
 - Ambient temperature of the housing with electronics of T3111Ex transmitter is not allowed exceed 60 °C.
 - Don’t connect transmitter while power supply voltage is on.
 - Under certain extreme circumstances, the plastic enclosure of T3111Ex transmitter may store an ignition-capable level of electrostatic charge. The device shall not be installed in a location where the external conditions are conducive to the build-up of electrostatic charge. The equipment shall only be cleaned with a damp cloth.
-

Info mode

Several settings of installed transmitter are possible to verify without a use of the computer. It is necessary to connect at least power of current loop I1. Unscrew the transmitter lid and shortly press button between display and interconnection terminals by means of a tool (e.g. screwdriver).



The LCD display shows the type of value assigned to 1. output (here „%RH“ = relative humidity and „1“ = loop I1). Upper line displays value of the current corresponding to measured value on the lower line (here 4 mA corresponds to 0 %RH).



Press button again to get value for upper point of the 1. output (here „%RH“ = relative humidity and „1“ = loop I1). Upper line displays value of the current corresponding to measured value on the lower line (here 20 mA corresponds to 100 %RH).



After next press of the button LCD display shows the type of value assigned to 2. output (here „°C“ = temperature and „2“ = loop I2). Upper line displays value of the current corresponding to measured value on the lower line (here 4 mA corresponds to -30 °C).



Press button again to get value for upper point of the 2. output (here „°C“ = temperature and „2“ = loop I2). Upper line displays value of the current corresponding to measured value on the lower line (here 20 mA corresponds to 80 °C).

Press button again to end info mode and display actual measured values.

Warning

- During info mode no measurement and no output current generation proceed. The transmitter stays at info mode 15 s, and then automatically goes back to measuring cycle.
 - The verifying of settings of the T3111Ex transmitter is permitted only in non-hazardous area.
-

Modification of device adjustment

Device adjustment is performed by means of the optional SP003 communication cable, connected to USB port of the PC. It is necessary to have installed configuration program Tsensor on the PC (program is free to download at www.cometsystem.cz). During installation please take care about installation of driver for USB communication cable.

- unscrew four screws of the device lid and remove the lid. If device is already installed to measuring system, disconnect wires from terminals
- connect SP003 communication cable to the PC. Installed USB driver detect connected cable and create virtual COM port inside the PC
- run installed Tsensor program and continue in accordance with his instructions
- when new setting is saved and finished, disconnect the cable from the device, connect wires into its terminals and place the lid back to the device

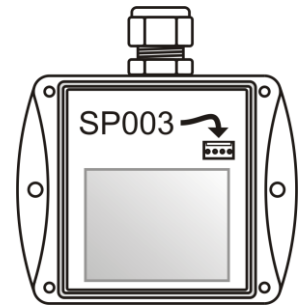

Warning

- Modification of adjustment of the T3111Ex transmitter using a cable SP003 is permitted only in non-hazardous area.
-

Error states of the device

Device continuously checks its state during operation. In case error is found LCD displays corresponding error code:

- Error 0** - first line displays „Err0“ (output current value is < 3.8 mA). Check sum error of stored setting inside device's memory. This error appears if incorrect writing procedure to device's memory occurred or if damage of calibration data appeared. At this state device does not measure and calculated values. It is a serious error, contact distributor of the device to fix.
- Error 1** - there is a reading „Err1“ on LCD display (output current value is > 22 mA). Measured or computed value is higher than upper limit. This state appears in case of:
- measured temperature is higher than approximately 600 °C (i.e. high non-measurable resistance of temperature sensor, probably opened circuit)
 - relative humidity value is higher than 100 %, i.e. damaged humidity sensor, or humidity calculation of humidity is not possible (due to error during temperature measurement)
 - calculation of the computed value is not possible (error during measurement of temperature or relative humidity or value is over range)
- Error 2** - there is a reading „Err2“ on LCD display (output value is < 3.8 mA). Measured or computed value is below lower limit of allowed full scale range. This state appears in case of:
- measured temperature is lower than approximately -210 °C (i.e. low resistance of temperature sensor, probably short circuit).
 - relative humidity value is lower than 0 %, i.e. damaged sensor for measurement of relative humidity, or calculation of relative humidity is not possible (due to error during temperature measurement)
 - calculation of the computed value is not possible (error during measurement of temperature or relative humidity)
- Error 3** - there is a reading „Err3“ on LCD display upper line. Error of internal A/D converter appeared (converter does not respond, probably damage of A/D converter). No measurement and calculations of values are proceeded. It is a serious error, contact distributor of the instrument.

Technical support and service

Technical support and service is provided by distributor. For contact see warranty certificate. You can use discussion forum at web address www.forum.cometsystem.cz.

Technical data

Measured values

Temperature:

Accuracy:	$\pm 0.4\text{ }^{\circ}\text{C}$
Measuring range:	0 to $+105\text{ }^{\circ}\text{C}$
Resolution:	$0.1\text{ }^{\circ}\text{C}$
Response time:	$t_{90} < 6\text{ min}$ T3111 $t_{90} < 6\text{ min}$ T3111L $t_{90} < 6\text{ min}$ T3111Ex $t_{90} < 16\text{ min}$ T3111P (temperature step $20\text{ }^{\circ}\text{C}$)

Relative humidity:

Accuracy:	$\pm 2.5\text{ \%RH}$ from 5 to 95 %RH at $23\text{ }^{\circ}\text{C}$
Measuring range:	0 to 100 %RH
Resolution:	0.1 \%RH
Response time:	$t_{90} < 30\text{ s}$ (humidity step 65 %RH, constant temperature)

Accuracy data are valid for values displayed on LCD display. For accuracy of analog outputs are valid this data in case, when the output range is set within the range of measurement.

Relative humidity and temperature restriction:

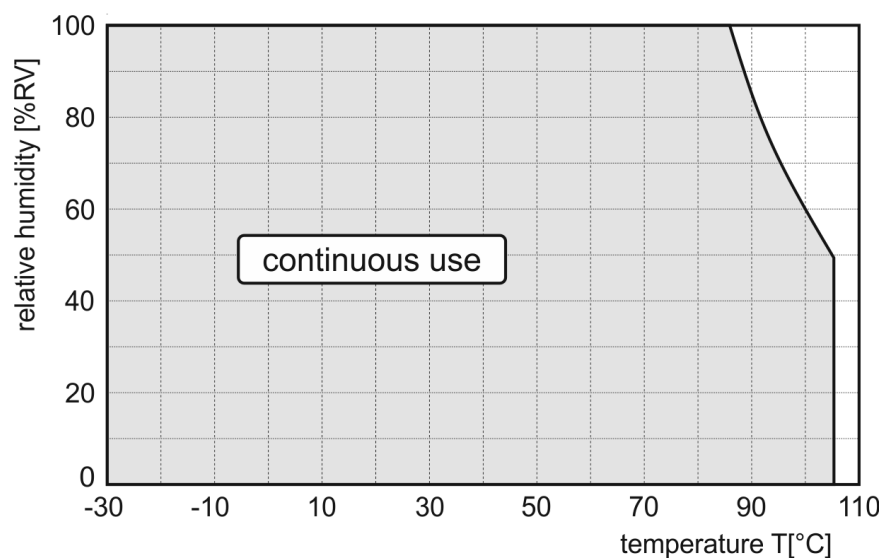

Calculated humidity values

Dew point temperature::

Accuracy: $\pm 1.5^{\circ}\text{C}$ at ambient temperature $T < 25^{\circ}\text{C}$ and $\text{RH} > 30\%$, for more details see graphs

Measuring range: -60 to $+80^{\circ}\text{C}$

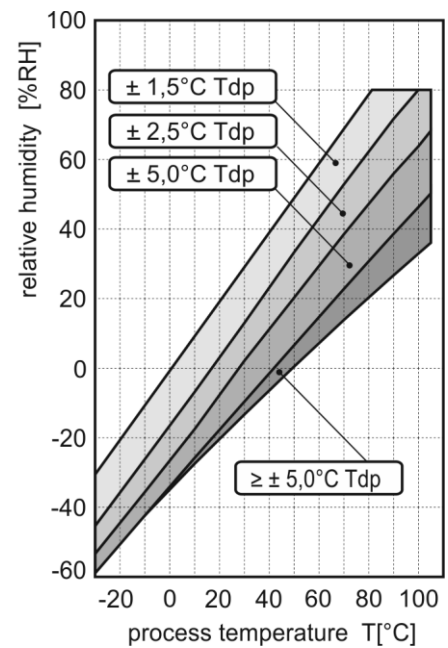
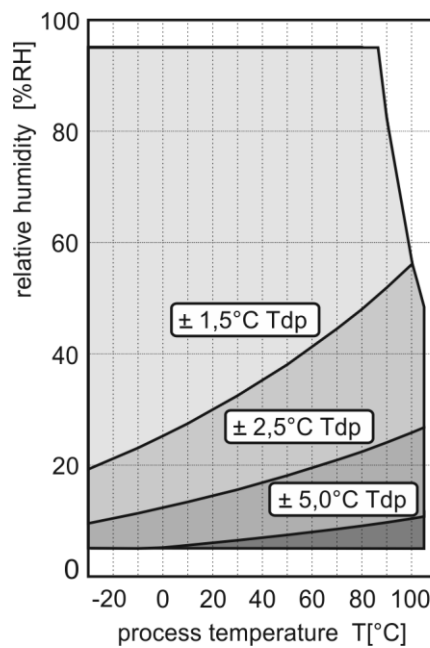

Absolute humidity:

Accuracy: $\pm 1.5 \text{ g/m}^3$ at ambient temperature $T < 25^{\circ}\text{C}$, for more details see graph

Measuring range: 0 to 400 g/m^3

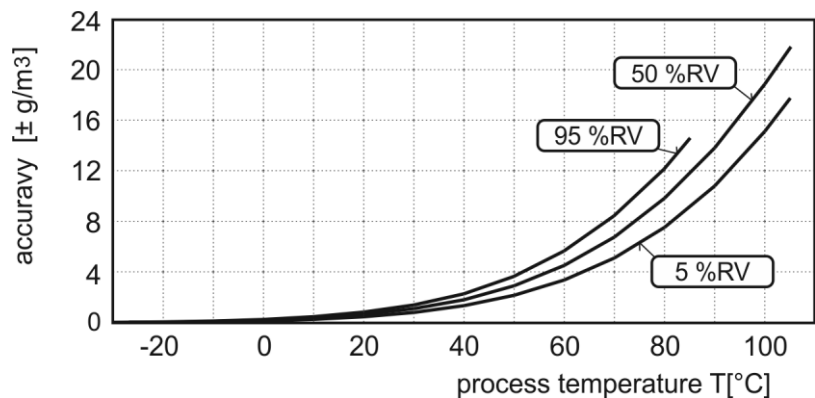

Specific humidity

This value depends on atmospheric pressure. Pressure for quantities calculation is stored in device memory. Default value is 1013hPa and can be changed by software.

Accuracy: ± 2 g/kg at ambient temperature $T < 35$ °C
Measuring range: 0 to 550 g/kg

Mixing ratio

This value depends on atmospheric pressure. Pressure for quantities calculation is stored in device memory. Default value is 1013hPa and can be changed by software.

Accuracy: ± 2 g/kg at ambient temperature $T < 35$ °C
Measuring range: 0 to 995 g/kg

Specific enthalpy

This value depends on atmospheric pressure. Pressure for quantities calculation is stored in device memory. Default value is 1013hPa and can be changed by software.

Accuracy: ± 4 kJ/kg at ambient temperature $T < 35$ °C
Measuring range: 0 to 995 kJ/kg

The values computed from ambient temperature and relative humidity including their accuracy you can exactly determine by the program **Conversions**. It is free to download at www.cometsystem.cz.

General

Power supply voltage:

9 to 30 Vdc

Current output in case of error:

< 3.8 mA or > 22 mA

Recommended calibration interval:

1 year (*relative humidity 1 year, temperature 2 years*)

Protection:

housing with electronics IP65, sensors are located in cover with IP40 protection

Mechanical connection of probe T3111P:

G1/2 with O-ring

Storage temperature range:

-30 to +80 °C

Storage relative humidity range:

5 to 95 %RH (no condensation)

Certification of T3111Ex transmitter:

Certificate: FTZÚ 13 ATEX 0189X

Marking:  II 3G Ex ic IIC T6 Gc

Compliance with standards: EN 60079-0:2012 and EN 60079-11:2012

Intrinsically safe parameters of current loops I1 and I2:

$U_i = 30 \text{ V}$, $I_i = 100 \text{ mA}$, $I_o = 22 \text{ mA}$, $C_i \sim 0$, $L_i \sim 0$

Special condition for safe use (sign "X"): Under certain extreme circumstances, the plastic enclosure may store an ignition-capable level of electrostatic charge. The device shall not be installed in a location where the external conditions are conducive to the build-up of electrostatic charge. The equipment shall only be cleaned with a damp cloth.

Electromagnetic compability:

EN 61326-1

Weight: approximately

T3111, T3111L, T3111Ex probe 1m	210 g
T3111, T3111L, T3111Ex probe 2m	250 g
T3111, T3111L, T3111Ex probe 4m	330 g
T3111P probe 1m	260 g
T3111P probe 2m	300 g
T3111P probe 4m	380 g

Housing material:

ABS

Material of the probe T3111P:

duralumin with the black eloxal surface finish

Operating conditions

Temperature operating range of housing with electronics:

-30 to +80 °C **T3111**
-30 to +80 °C **T3111L**
-30 to +80 °C **T3111L**

Ambient temperature range of the housing with electronics:

-30 to +60 °C **T3111Ex**

Temperature operating range of the probe:

-30 to +105 °C

Relative humidity operating range:

0 to 100 %RH (no condensation)

Operating pressure range of the probe T3111P:

up to 25 bar

Air flow velocity (T3111P probe):

up to 25 m/s at a pressure of 1 bar (1m/s at a pressure of 25 bar)

End of operation

Dispose of the device according to statutory regulations.

Dimensions

T3111
T3111Ex

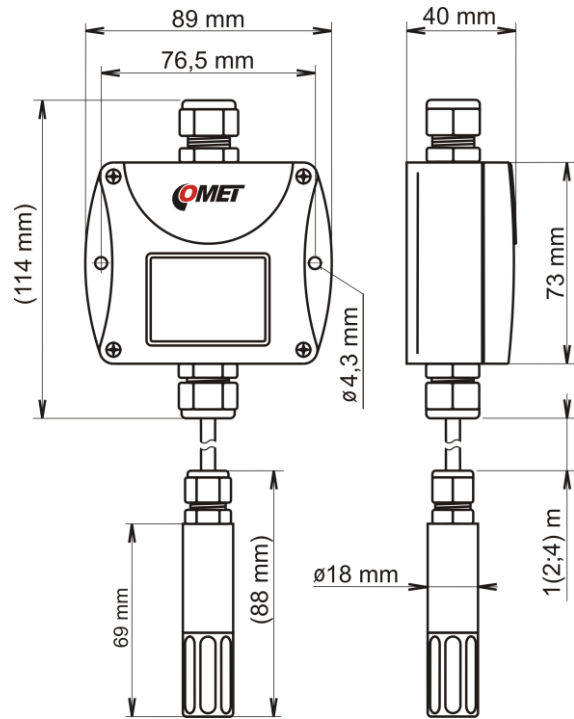

T3111L

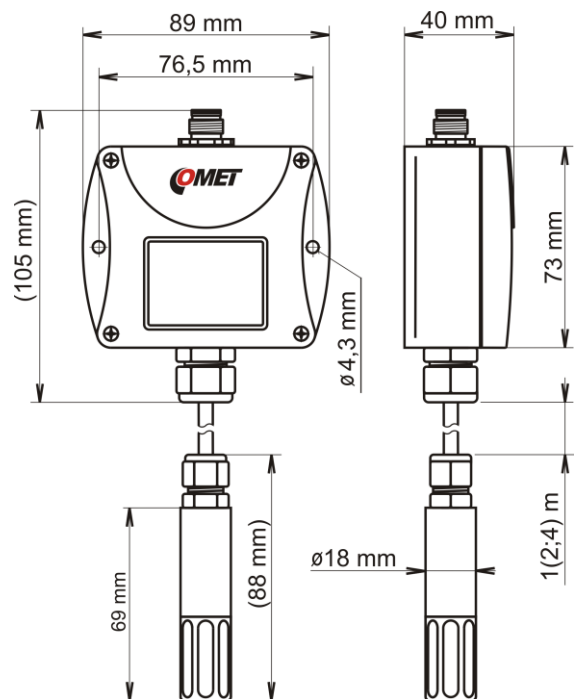

T3111P

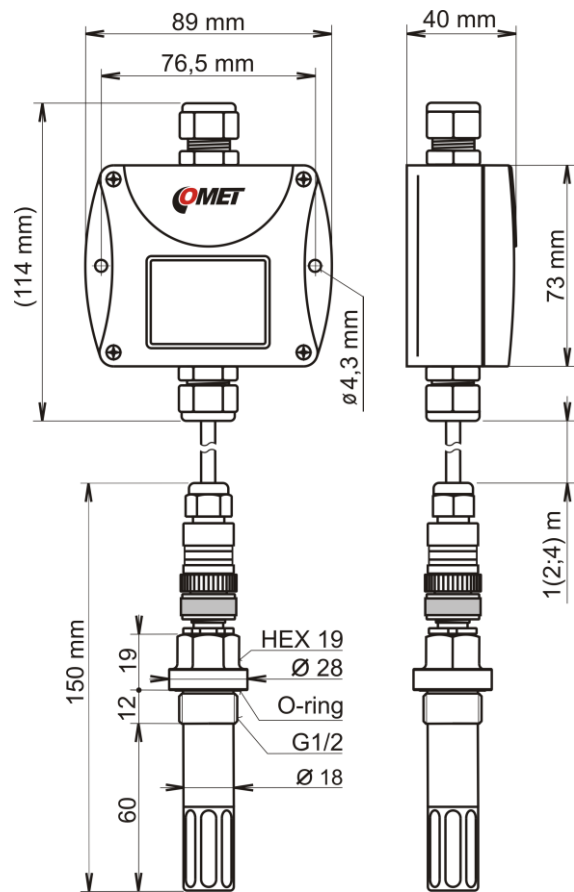

Typical application wiring

**T3111
T3111P**

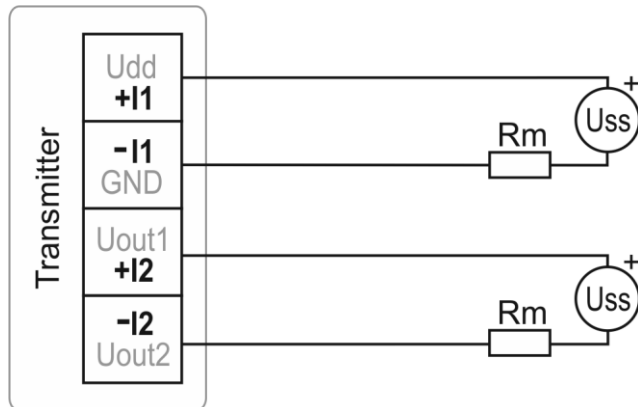

Loop resistance value $R_c = R_m + \text{resistance of wires}$ shall fulfill the condition $R_c[\Omega] < 40 \times U_{ss}[V] - 360$.

T3111Ex

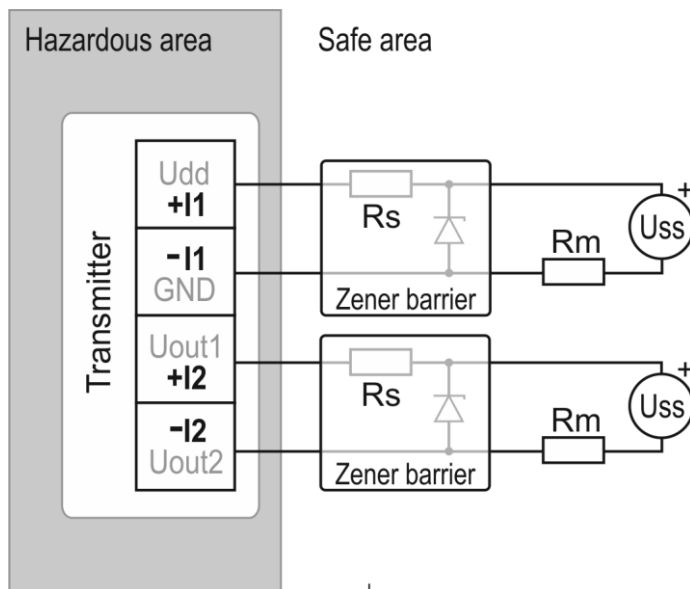

Loop resistance value $R_c = R_m + R_s + \text{resistance of wires}$ shall fulfill the condition $R_c[\Omega] < 40 \times U_{ss}[V] - 360$.

Intrinsically safe parameters of the transmitter:

$$U_i = 30 \text{ V}, I_i = 100 \text{ mA}, I_o = 22 \text{ mA}, C_i \sim 0, L_i \sim 0$$

T3111L

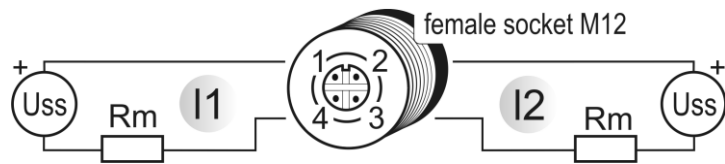

Loop resistance value $R_c = R_m + \text{resistance of wires}$ shall fulfill the condition $R_c[\Omega] < 40 \times U_{ss}[V] - 360$.

Appendix A

The probe for measuring the moisture of compressed air should be placed directly on the pressure pipelines to achieve higher measurement accuracy and fast response times. But there are cases where such placement is not possible. The reason is the high air speed, high temperature, high pollution, small diameter pipes, etc. Such situation can be solved by placing the probe into the flow measuring chamber. The picture shows the basic layout of the sampling system with chamber SH-PP.

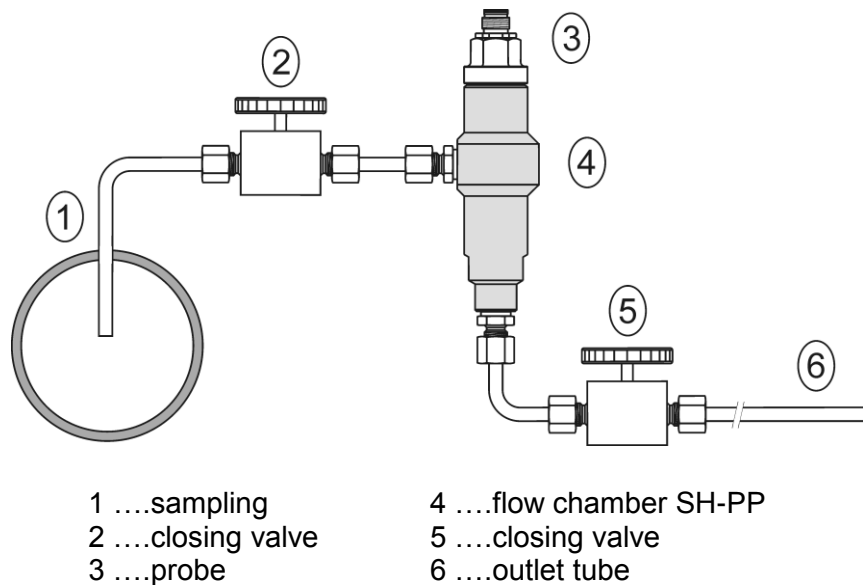

sampling (1) - end of the tube placed in the centre of pressure pipelines (distribution of moisture in the pipe cross-section is not homogeneous). To achieve fast response times to shorten the length of the sample tubes to a minimum (a few meters).

closing valve (2) - allows access to the sample system without interrupting the main line

closing valve (5) - the sample flow is regulated by this valve. Measurement accuracy is not typically affected by the sample flow rate, only the response time of measurement is increased with decreasing value of sample flow rate.

outlet tube (6) - if the measured sample of air is released into the atmosphere, select the length of the outlet tube of 1.5 m (recommended for tube diameter 6mm). The reason is to ensure the accuracy of the sample in the flow chamber and avoid back diffusion of moisture from the ambient air..

That basic structure of sampling system can be supplemented with filters, coolers, flow measurement, pressure measurement, etc. For the accurate operation of sampling system is important to ensure perfect tightness of all connections and to use corrosion-resistant materials. Tube inclination is chosen so as to avoid the accumulation of fluid in the system.

Technical specification – flow chamber SH-PP

Material of flow chamber:	stainless steel (DIN 1.4301)
Inlet and outlet connection:	G1/8
Probe connection:	G1/2
Sample flow rate:	0.1 to 3 l/min
Operating pressure:	up to 25 bar
Weight:	580 g

Note: Screw-coupling not included

