



Web Sensors

Monitoring of temperature, humidity, atm. pressure and CO₂ via Ethernet

The image shows a woman in a dark suit holding a globe of the Earth. Several white OMET sensors are connected to the globe via Ethernet cables. One sensor is also connected to a tablet computer. The tablet screen displays a web interface with the following data:

Temperature 8.5°C alarm none <small>min: -11.2°C max: 8.8°C</small>	Relative humidity 23.0%RH alarm low <small>min: 20.0%RH max: 98.2%RH</small>
Dew point -11.3°C alarm low <small>min: -14.6°C max: 1.7°C</small>	Atmospheric pressure 1019.4hPa alarm high <small>min: 1001.1hPa max: 1037.5hPa</small>
Settings *	About ?

Copyright © 2013, Comet system s.r.o. All rights reserved.



- Web Sensors of temperature, humidity, atmospheric pressure and CO₂ with two-state inputs and relay outputs
- high quality, accurate and stable sensors
- values computed from ambient temperature and relative humidity
- traceable calibration certificate with traceability with EN ISO/IEC 17025



Applications

These days there is a high demand for on-line monitoring and uninterrupted records of different type of values. With very fast development of computer technologies, it is still easier and easier to connect different kind of monitoring devices directly to Ethernet lines, to the places where it was not possible before. If the Ethernet net has direct connection to the internet, then all data could be sent immediately around the world without the need for any additional costs. This high requirements could be done easily by Web Sensors and sensors with Ethernet output which can ensure long term reliability, stable parameters and very easy installation and usage. The devices can be protected against blackouts and data loss at the customer's site. Of course PoE supply is an option.

Continuous monitoring of critical parameters such as temperature and relative humidity can be very easily done by the help of Web Sensors. This production line consists of sensors for measuring temperature, relative humidity, CO₂ concentration, atmospheric pressure, and the 4-20mA signal. Most sensors are equipped with an LCD display and can be easily incorporated into the existing network infrastructure.

The Web Sensors evaluate the measured values and in case of exceeding the alarm limits, the unit will send an email to a pre-set address, so this ensures that you are always informed of the conditions in your offices, server rooms, warehouses and factories, and everywhere where is necessary to monitor the supported values.

By connecting directly to a computer network the thermometer or humidity meter can be integrated into the control systems of different manufacturers using SNMP, MODBUS TCP, SOAP, syslog. Of course data in many formats is also available, for example XML and so on.

Applications of Web Sensors:

- » Server rooms
- » Offices and residential premises
- » Building management
- » Storage of food and drugs
- » Museums and galleries
- » Technological processes and production
- » Industry

Computed values:

- Dew point temperature (°C or °F)**
- Absolute humidity (g/m³)**
- Specific humidity (g/kg)**
- Mixing ratio (g/kg)**
- Specific enthalpy (kJ/kg)**

Measured values



Temperature

Temperature is measured by RTD sensor Pt1000/3850 ppm which can be integrated into the housing of transducer, into the duck stem or can be used on the cable as well. The measured temperature can be displayed in °C or °F, according to the settings of the sensor.



Relative humidity

State-of-the-art capacitive polymer sensor ensures excellent long term calibration stability and inertia against water and condensation. Transmitters are available in wall-mount, duct mount.

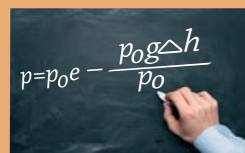

Barometric pressure

Transmitter for measuring of barometric pressure is equipped with an absolute pressure sensor of high accuracy which ensures excellent long term stability. The display reading and pressure output is user selectable in these units: hPa, kPa, mbar, mmHg, inHg, inH₂O, PSI, oz/in².



Carbon dioxide level - CO₂

A multiple point CO₂ and temperature adjustment procedure leads to excellent CO₂ measurement accuracy over the entire temperature working range; this is a must for process control and outdoor applications. The dual wavelength NDIR CO₂ sensing procedure compensates automatically for ageing effects. The CO₂ module is highly insensitive to pollution and offers maintenance free operation and outstanding long term stability.

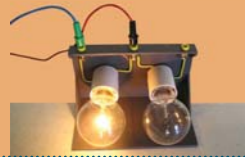

Current - mA

Transfer of current loops 0-20 mA (4-20 mA) to the Ethernet network. Ethernet network reduces installation costs and accelerates deployment.



Binary inputs

Selected devices feature up to three binary inputs for connecting smoke detectors, floodings, breaking glass, door contacts, etc. A voltage-free contact, open collector or two-state voltage signal can be connected.

Pharmaceuticals and laboratories

Monitoring of areas and places for storage of drugs at temperatures down to - 200 °C.



Technological processes and production

Monitoring of storage conditions and production processes in the temperature range from - 200 °C to + 600 °C.

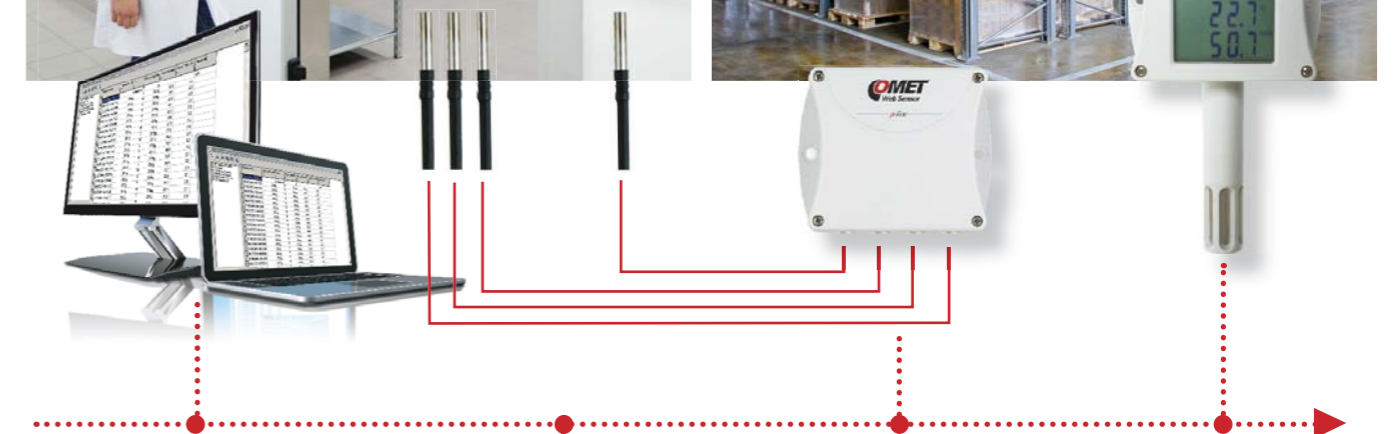

Server rooms

Monitoring of conditions in the data centers and in 19" racks, including detection of the state of flooding, opening / closing doors (windows), movement and smoke, etc.



Food industry

Monitoring of critical variables in relation to HACCP regulations with the possibility of immediate alert to unforeseen events that could lead to the devaluation of goods.





Web Sensors with Ethernet connection are designed to measure current 4 - 20mA (0-20mA), temperature, relative humidity, CO₂ and barometric pressure of air in non-aggressive environments. Measured values are according to device type. Devices with relative humidity measurement can show one of computed values: dew point temperature, absolute humidity, specific humidity, mixing ratio and specific enthalpy. Temperature units are °C or °F.

The visual indication of the CO₂ concentration is provided by three-colour LED.

Web Sensor of T-line is equipped with LCD display where current values can be displayed.

The device setup can be made by the TSensor software or web interface. TSensor software can be downloaded for free from the manufacturer's website.

The latest version of firmware for your device with new features and even for older devices is available on the producer's site www.cometsystem.cz/support/firmware-update.



WWW server

Actual measured values are accessible via powerful embedded web server. Web pages are ready for access from mobile devices like smartphones and tablets. Device configuration via web pages is possible too. Web Sensors allow to user customize the design of web pages.



History values memory

Graphs with history values are accessible via web pages. Modern HTML5 canvas graphic component allows to use graphs from thousands of devices. It is not a problem to show graphs on tablets or smartphones. All modern web browsers are supported - Firefox, Opera, Chrome or Internet Explorer 9.



Email

Warning emails are sent when measured value exceed selected limits. Emails are also sent when values return back into safe range. SMTP authentication is supported, but SSL not. Emails with CSV file attachment can be sent at selected intervals.



History export to CSV

History values can be exported for further processing by the CSV file. CSV file can be processed inside spreadsheet application like Microsoft Excel or OpenOffice Calc. CSV file can be downloaded from web pages or periodically sent as email attachment.



ModbusTCP protocol

Modbus protocol for communication with SCADA systems or third party software. Devices use Modbus TCP protocol version. Two Modbus clients can be connected to the device at one moment.



Actual values via XML

XML protocol for actual measured values reading. This protocol is suitable for Web Sensors integration into 3rd party SCADA systems.



SNMP protocol

SNMP version 1 protocol for IT infrastructure. Using SNMP protocol you can read actual measured values, alarm statuses and alarm parameters. Via SNMP protocol is also possible to get last 1000 measured values from the history table. MIB tables with OID description are available.



SNMP Trap

SNMP Trap for IT infrastructure. Web Sensors allow sending Traps to selected Trap receiver server. Traps are sent in case of alarm on channel or at error states like unable to send email, unable to deliver SOAP message, etc.



SOAP protocol

Web Sensors allow to send currently measured values via SOAP v1.1 protocol. The device sends values in XML format to the web server. The advantage of this protocol is that communication is initialized by the device side. Therefore it is not necessary to use port forwarding.



Syslog protocol

Syslog protocol for IT infrastructure monitoring systems. Web Sensors allow sending text messages to selected Syslog server. Messages are sent in case of alarm on channel or at error states like unable to send email, unable to deliver SOAP message, etc.



SNTP protocol - time synchronization

Time synchronisation with SNTP server. Actual time is shown at web pages and is necessary for timestamps inside CSV files. Synchronisation interval can be set to one day or to one hour.

Current measured values and sensor settings can be accessed directly through the web interface from your web browser. TSensor software, which is available on our website in the section Software, can be also used for setting the sensor.

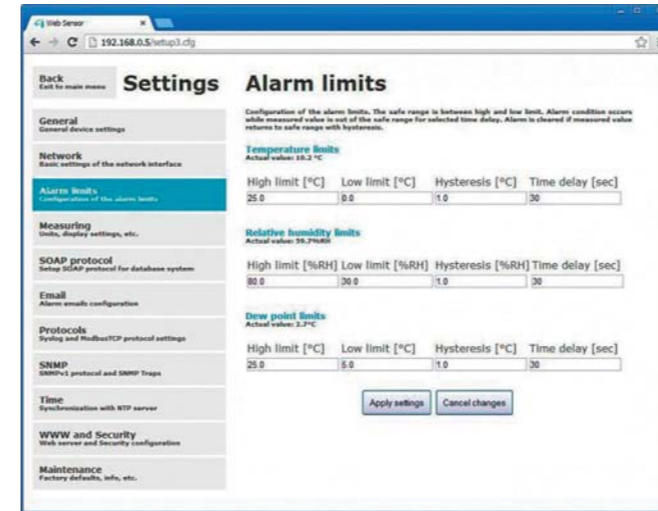

Sensor settings can also be done directly in a web browser in your PC, smartphone or tablet. All you need to do is enter the IP address of the sensor, open Settings and set up everything from communication to alarm e-mails.



Graphs of actual values can also be displayed through a Web browser. You can display up to one thousand measured values.

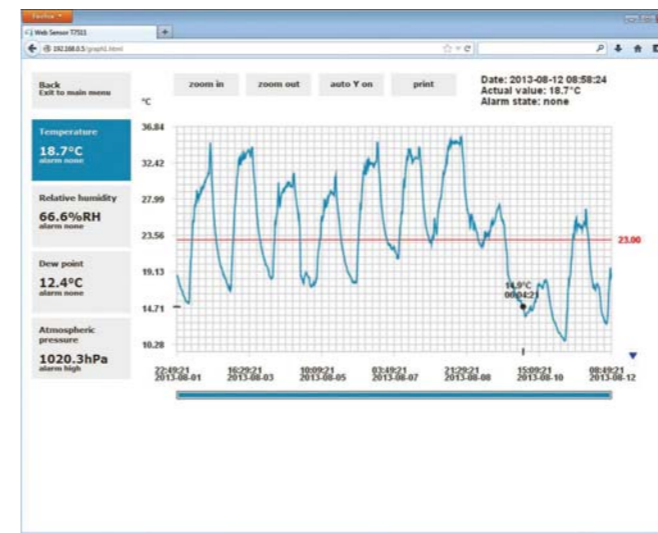

Current measured values are available on-line directly on a web browser from anywhere, all you need to do is enter the IP address. Alarms are indicated by a red field.

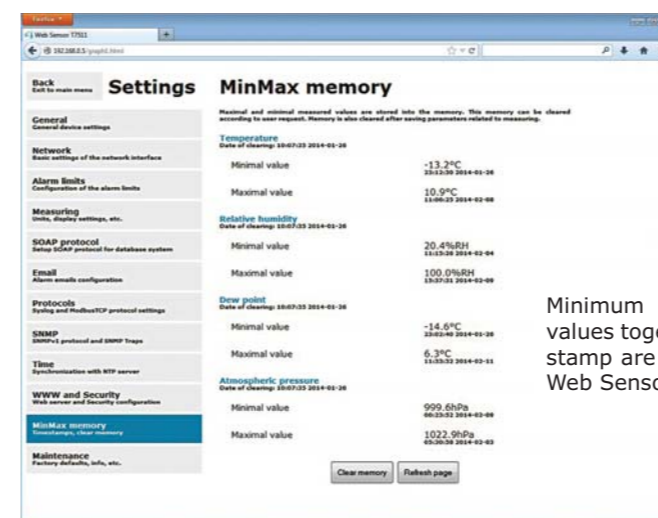

Minimum and maximum values together with a time stamp are recorded by the Web Sensor.



Web Sensor *t-line*

Common parameters:

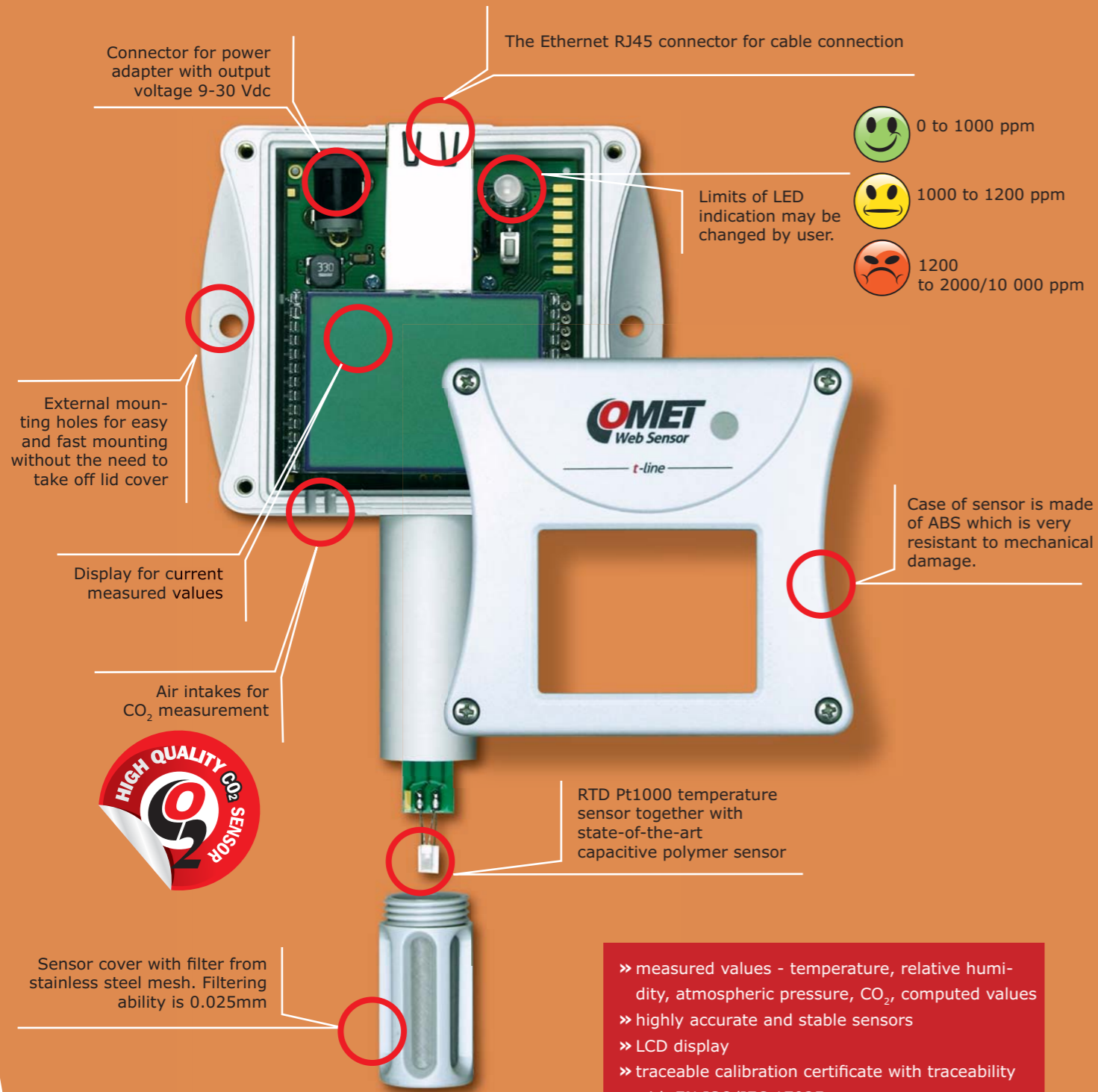

- » measured values - temperature, relative humidity, atmospheric pressure, CO₂, computed values
- » highly accurate and stable sensors
- » LCD display
- » traceable calibration certificate with traceability with EN ISO/IEC 17025

Sensor models:

MEASURED VALUES	without PoE*	with PoE**
atmospheric pressure	T2514	
relative humidity + temperature	T3510, T3511, T3511P	T3610, T3611
relative humidity + temperature + atmospheric pressure	T7510, T7511	T7610, T7611
temperature	T0510, T4511	T0610, T4611
CO ₂	T5540, T5541	
CO ₂ + relative humidity + temperature	T6540	

* Please see page 8 - 9 for sensor specification

** Please see page 10 - 11 for sensor specification

Low cost Web Sensor *p-line*

Common parameters:

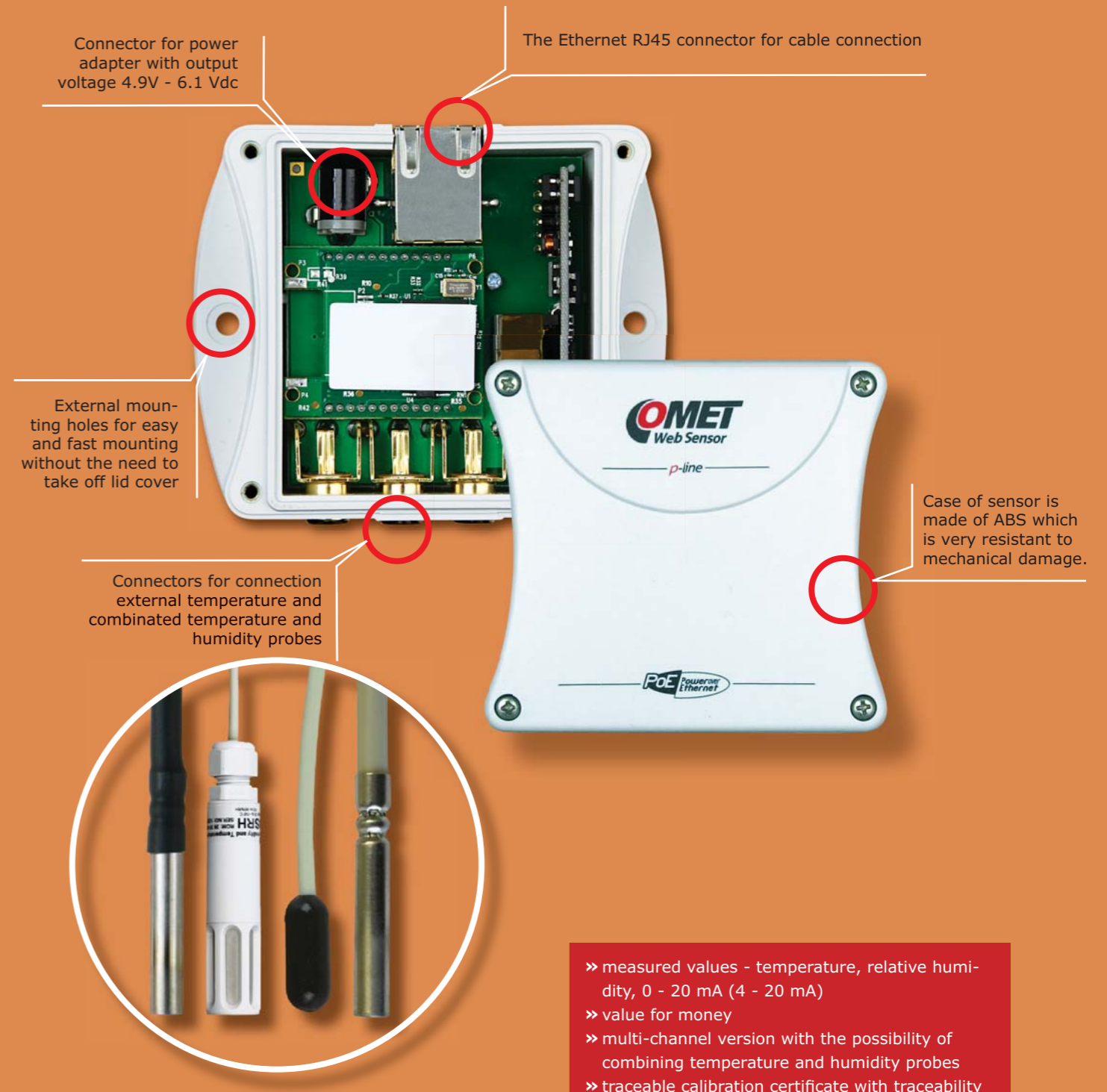

- » measured values - temperature, relative humidity, 0 - 20 mA (4 - 20 mA)
- » value for money
- » multi-channel version with the possibility of combining temperature and humidity probes
- » traceable calibration certificate with traceability with EN ISO/IEC 17025

Sensor models:

MEASURED VALUES	without PoE*	with PoE**
temperature	P8510	P8610
temperature + relative humidity*	P8511, P8541	P8631
0-20mA (4-20mA)	P2520	

* With the attached temperature and humidity probe - type DSRH (max. length 15 metres)

** Please see page 12 - 13 for sensor specification



Web Sensor *t-line* without PoE and their specification

Measured values		Temperature		Temperature, relative humidity			Temperature, relative humidity, atm. pressure		Atm. pressure	Temperature, relative humidity, CO ₂	CO ₂	
SENSOR MODEL		T4511	T0510	T3510	T3511	T3511P	T7510	T7511	T2514	T6540	T5540	T5541
temperature	range	-200 to +600°C	-30 to +80°C	-30 to +80°C	-30 to +105°C	-30 to +105°C	-30 to +80°C	-30 to +105°C	-	-30 to +80°C	-	-
	accuracy	±0.2°C without temp. probe	±0.6°C	±0.6°C	±0.4°C	±0.4°C	±0.6°C	±0.4°C	-	±0.6°C	-	-
relative humidity **	range	-	-	0 to 100 %RH	0 to 100 %RH	0 to 100 %RH	0 to 100 %RH	0 to 100 %RH	-	0 to 100 %RH	-	-
	accuracy	-	-	±2.5 %RH	±2.5 %RH	±2.5 %RH	±2.5 %RH	±2.5 %RH	-	±2.5 %RH	-	-
atm. pressure **	range	-	-	-	-	-	600 to 1100 hPa	600 to 1100 hPa	600 to 1100 hPa	-	-	-
	accuracy	-	-	-	-	-	±1.3 hPa	±1.3 hPa	±1.3 hPa	-	-	-
CO ₂ ***	range	-	-	-	-	-	-	-	-	0 to 2000 ppm*	0 to 2000 ppm*	0 to 10000 ppm
	accuracy	-	-	-	-	-	-	-	-	± (50ppm+2% of measured value)	± (50ppm+2% of measured value)	± (110ppm+5% of measured value)
computed humidity values		NO	NO	YES	YES	YES	YES	YES	NO	YES	NO	NO
supply voltage		9-30 V	9-30 V	9-30 V	9-30 V	9-30 V	9-30 V	9-30 V	9-30 V	9-30 V	9-30 V	9-30 V
recommended calibration interval		two years	two years	one year	one year	one year	one year	one year	one year	one year	five years	five years
protection class of the case with electronics		IP30	IP30	IP30	IP30	IP30	IP30	IP30	IP30	IP30	IP30	IP30
protection class of the sensor cover		-	-	IP40	IP40	IP40	IP40	IP40	-	IP40	-	IP 65
temperature operating range of the case with electronics		-30 to +80°C	-30 to +80°C	-30 to +80°C	-30 to +80°C	-30 to +80°C	-30 to +80°C	-30 to +80°C	-30 to +80°C	-30 to +60°C	-30 to +60°C	-30 to +80°C
temperature operating range of the measuring element		-	-	-30 to +80°C	-30 to +105°C	-30 to +105°C	-30 to +80°C	-30 to +105°C	-	-30 to +80°C	-	-40 to +60°C
humidity operating range without condensation		0 to 100 %RH	0 to 100 %RH	0 to 100 %RH	0 to 100 %RH	0 to 100 %RH	0 to 100 %RH	0 to 100 %RH	0 to 100 %RH	5 to 95 %RH	5 to 95 %RH	0 to 100 %RH
barometric pressure operating range		-	-	-	-	up to 2,5MPa	-	-	-	850 to 1100hPa	850 to 1100hPa	850 to 1100hPa
mounting position		any position	connectors upwards	connectors upwards	any position	any position	connectors upwards	any position	any position	connectors upwards	connectors upwards	any position
storage temperature range		-30 to +80°C	-30 to +80°C	-30 to +80°C	-30 to +80°C	-30 to +80°C	-30 to +80°C	-30 to +80°C	-30 to +80°C	-40 to +60°C	-40 to +60°C	-40 to +60°C
electromagnetic compatibility		EN 61326-1	EN 61326-1	EN 61326-1	EN 61326-1	EN 61326-1	EN 61326-1	EN 61326-1	EN 61326-1	EN 61326-1, EN 55011	EN 61326-1, EN 55011	EN 61326-1, EN 55011
weight		145 g	145g	155 g	210 (250,330) g	260(300,380)g	155g	210 (250,330)g	130g	160g	140g	240 (270, 330)g

* custom range 10000 ppm for an extra fee

** accuracy of relative humidity in range 5% to 95% and of atmospheric pressure at 23°C

*** accuracy of CO2 concentration of measurement at 25°C and 1013 hPa

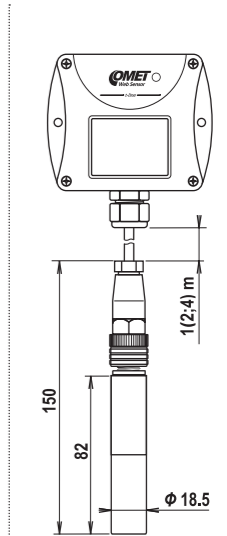
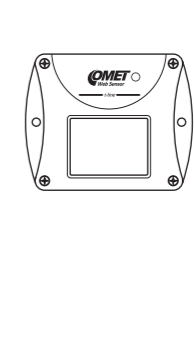
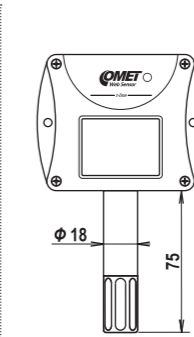
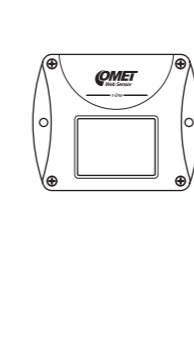
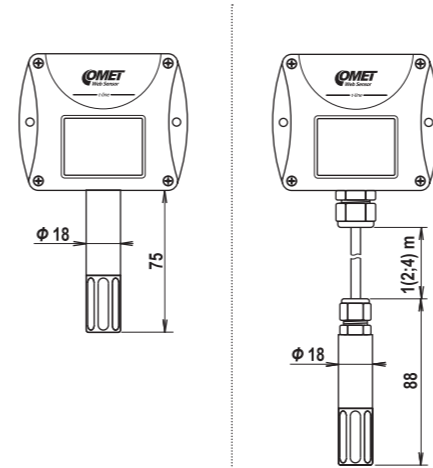
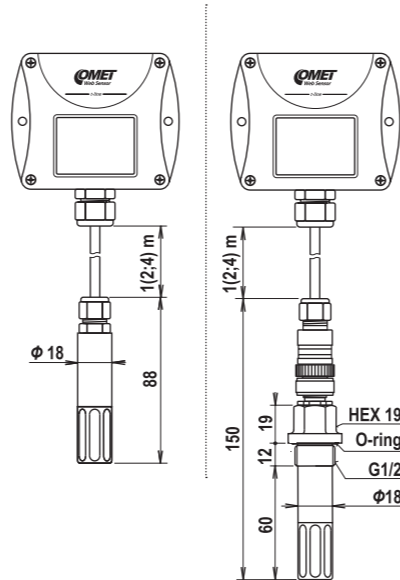
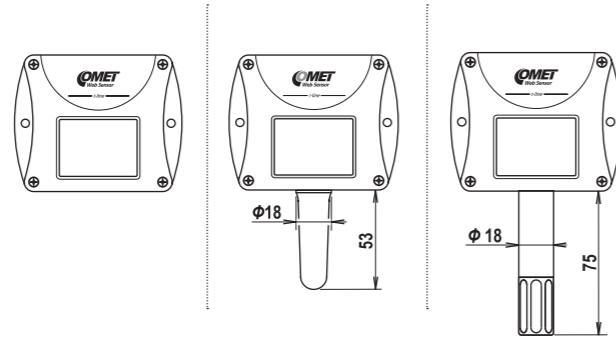
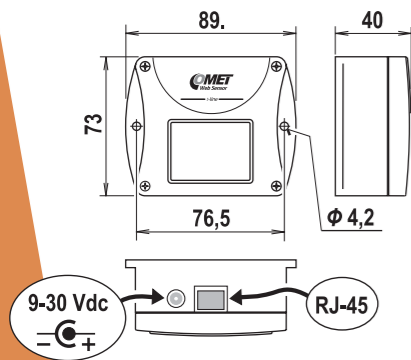

Device without PoE - connection procedure

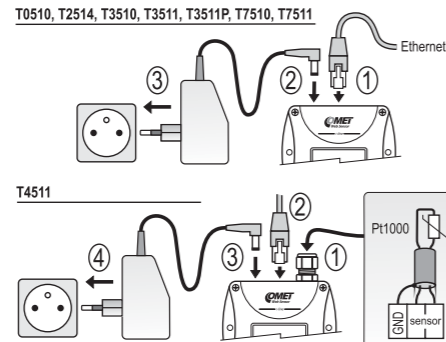

Computed values

Specific humidity
Accuracy: ±2.1 g/kg at ambient temperature T < 35 °C
Range: 0 to 550 g/kg

Dew point temperature
Accuracy: ±1.5°C at ambient temperature T < 25°C and relative humidity RH > 30%, for more details see manual
Range: -60 to +80 °C (-76 to 176 °F)

Mixing ratio
Accuracy: ±2.2 g/kg at ambient temperature T < 35 °C
Range: 0 to 995 g/kg

Absolute humidity
Accuracy: ±3 g/m³ at ambient temperature T < 25 °C
for more details see manual
Range: 0 to 400 g/m³

Specific enthalpy
Accuracy: ± 4kJ/kg at ambient temperature T < 25 °C
Range: 0 to 995 kJ/kg



Web Sensor *t-line* with PoE and their specification

Common parameters:

The Ethernet RJ45 connector for cable connection. Where power over Ethernet is used, the network infrastructure must be compatible with IEEE 802.3af standard.

Connector for power adapter with output voltage 4.9 - 6.1 Vdc

Case of sensor is made of ABS which is very resistant to mechanical damage.

Mounting holes for mounting the unit on the wall

Display for current measured values

RTD Pt1000 temperature sensor together with state-of-the-art capacitive polymer sensor

Sensor cover with filter from stainless steel mesh. Filtering ability is 0.025mm

- » Power over Ethernet (PoE) according to IEEE 802.3af
- » measured values - temperature, relative humidity, atmospheric pressure, computed values
- » highly accurate and stable sensors
- » traceable calibration certificate with traceability with EN ISO/IEC 17025

Device with PoE - connection procedure

Ethernet interface with PoE

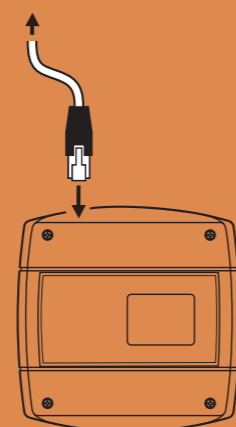

Measured values		Temperature		Temperature, relative humidity		Temperature, relative humidity, atm. pressure	
SENSOR MODEL		T4611	T0610	T3610	T3611	T7610	T7611
temperature	range	-200 to +600°C	-20 to +60°C	-20 to +60°C	-30 to +105°C	-20 to +60°C	-30 to +105°C
	accuracy	±0.2°C without temperature probe	±0.6°C	±0.6°C	±0.4°C	±0.6°C	±0.4°C
relative humidity*	range	-	-	0 to 100 %RH	0 to 100 %RH	0 to 100 %RH	0 to 100 %RH
	accuracy	-	-	±2.5 %RH	±2.5 %RH	±2.5 %RH	±2.5 %RH
atm. pressure*	range	-	-	-	-	600 to 1100 hPa	600 to 1100 hPa
	accuracy	-	-	-	-	±1.3 hPa	±1.3 hPa
computed humidity values		NO	NO	YES	YES	YES	YES
supply voltage		4.9 - 6.1V	4.9 - 6.1V	4.9 - 6.1V	4.9 - 6.1V	4.9 - 6.1V	4.9 - 6.1V
Power over Ethernet (PoE) according to IEEE 802.3af		YES	YES	YES	YES	YES	YES
recommended calibration interval		two years	two years	one year	one year	one year	one year
protection class of the case with electronics		IP30	IP30	IP30	IP30	IP30	IP30
protection class of the sensor cover		-	-	IP40	IP40	IP40	IP40
temperature operating range of the case with electronics		-20 to +60°C	-20 to +60°C	-20 to +60°C	-20 to +60°C	-20 to +60°C	-20 to +60°C
temperature operating range of the measuring element		-	-	-20 to +60°C	-30 to +105°C	-20 to +60°C	-30 to +105°C
humidity operating range without condensation		0 to 100 %RH	0 to 100 %RH	0 to 100 %RH	0 to 100 %RH	0 to 100 %RH	0 to 100 %RH
mounting position		any position	connectors upwards	connectors upwards	any position	connectors upwards	any position
storage temperature range		-30 to +80°C	-30 to +80°C	-30 to +80°C	-30 to +80°C	-30 to +80°C	-30 to +80°C
electromagnetic compatibility		EN 61326-1, EN 55011	EN 61326-1, EN 55011	EN 61326-1, EN 55011	EN 61326-1, EN 55011	EN 61326-1, EN 55011	EN 61326-1, EN 55011
weight		310g	310	320g	380 (420,500) g	320g	380 (420,500) g

* accuracy of relative humidity in range 5% to 95% and of atmospheric pressure at 23°C

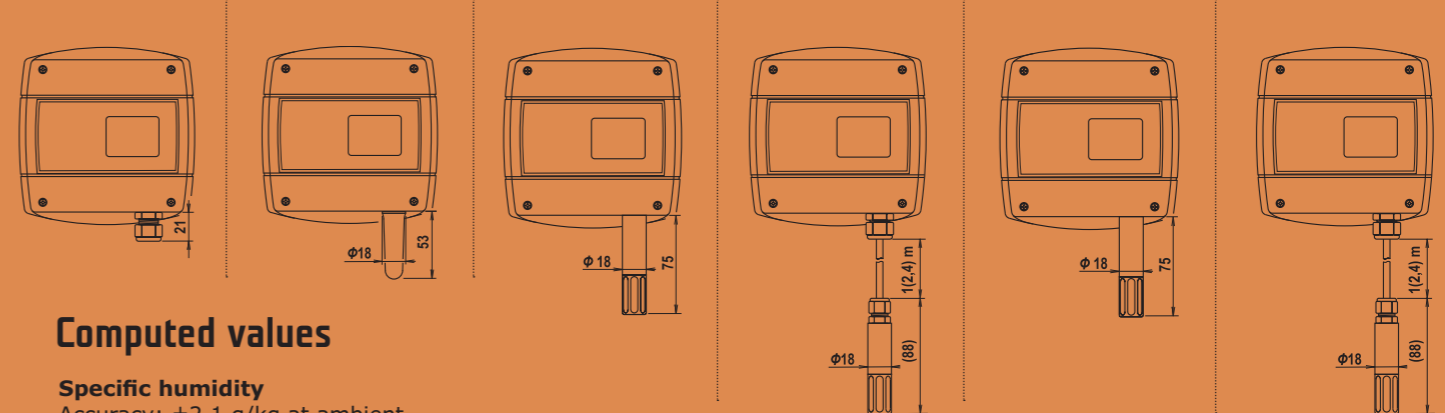
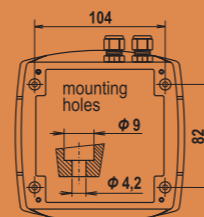
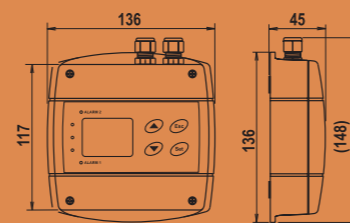

Computed values

Specific humidity

Accuracy: ±2.1 g/kg at ambient temperature T < 35 °C
Range: 0 to 550 g/kg

Dew point temperature

Accuracy: ±1.5°C at ambient temperature
T < 25°C and relative humidity RH > 30%, for more details see manual
Range: -60 to +80 °C (-76 to 176 °F)

Absolute humidity

Accuracy: ±3 g/m³ at ambient temperature T < 25 °C
for more details see manual
Range: 0 to 400 g/m³

Mixing ratio

Accuracy: ±2.2 g/kg at ambient temperature T < 35 °C
Range: 0 to 995 g/kg

Specific enthalpy

Accuracy: ± 4kJ/kg at ambient temperature T < 25 °C
Range: 0 to 995 kJ/kg



Web Sensor *p-line* and their specification

Measured values		Temperature		Temperature, relative humidity			Current - mA
SENSOR MODEL		P8510	P8610	P8511	P8631	P8541	P2520
temperature	range	-30 to +80°C	-20 to +60°C	according to the used probe*	according to the used probe*	according to the used probe*	-
	accuracy	±0.8°C above -10°C	±0.8°C above -10°C	according to the used probe*	according to the used probe*	according to the used probe*	-
		±2°C below -10°C	±2°C below -10°C	-	-	-	-
relative humidity	range	-	-	according to the used probe*	according to the used probe*	according to the used probe*	-
	accuracy	-	-	according to the used probe*	according to the used probe*	according to the used probe*	-
current measuring range		-	-	-	-	-	0-25mA (max. 30mA)
accuracy of current measurement		-	-	-	-	-	± 0.1% FS from 0°C to +50°C ± 0.3% FS from -30°C to +80°C
resolution		0.1°C	0.1°C	0.1°C, 0.1%RH	0.1°C, 0.1%RH	0.1°C, 0.1%RH	1uA
input impedance		-	-	-	-	-	20Ω
supply voltage		4.9 - 6.1V	4.9 - 6.1V	4.9 - 6.1V	4.9 - 6.1V	4.9 - 6.1V	9-30 V
Power over Ethernet (PoE) according to IEEE 802.3af		-		-		-	-
recommended calibration interval		two years	two years	according to the used probe*	according to the used probe*	according to the used probe*	two years
protection class of the case with electronics		IP30	IP30	IP30	IP30	IP30	IP30
temperature operating range of the case with electronics		-30 to +80°C	-20 to +60°C	-30 to +80°C	-20 to +60°C	-30 to +80°C	-30 to +80°C
humidity operating range without condensation		0 to 100 %RH	0 to 100 %RH	0 to 100 %RH	0 to 100 %RH	0 to 100 %RH	0 to 100 %RH
mounting position		cover downward	cover downward	any position	any position	any position	cover downward
storage temperature range		-30 to +80°C	-30 to +80°C	-30 to +80°C	-30 to +80°C	-30 to +80°C	-30 to +80°C
electromagnetic compatibility		EN 61326-1	EN 60950-1	EN 61326-1	EN 60950-1	EN 61326-1	EN 61326-1
weight		130g	145g	125g	140g	135g	150g

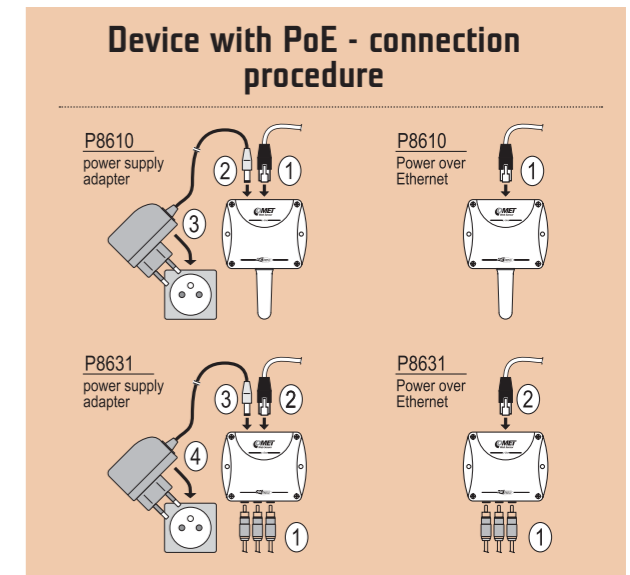
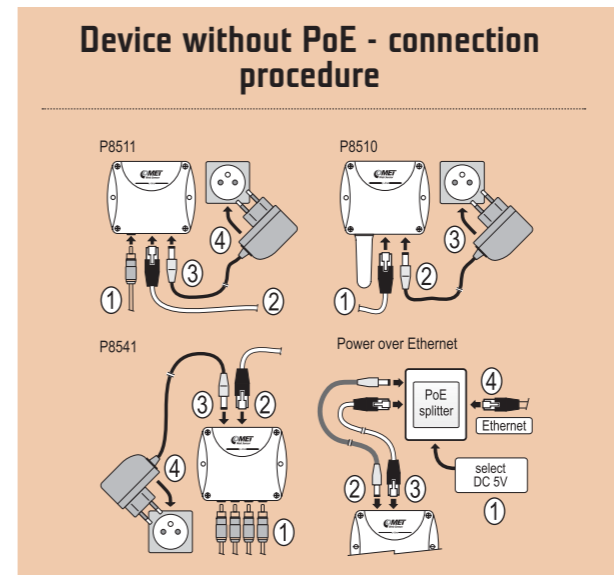

External probes		DSTG8/C	DSTGL40/C	DSTR162/C	DSRH
temperature	range	-50 to +100°C	-30 to +80°C	-30 to +80°C	0 to +50°C
	accuracy	±0.5°C from -10 to +80°C otherwise ±2°C	±0.5°C from -10 to +80°C otherwise ±2°C	±0.5°C from -10 to +80°C otherwise ±2°C	±2°C
relative humidity	range	-	-	-	0 to 100%RH
	Accuracy of Relative humidity (10% - 90% RH) at 25°C	-	-	-	±3.5% RH
recommended calibration interval		two years	two years	two years	one year
IP class of case with electronics		IP67	IP67	IP67	IP40
humidity operating range without condensation		0 to 100 %RH	0 to 100 %RH	0 to 100 %RH	0 to 100 %RH
mounting position		any position	any position	any position	any position
sensor dimensions (diameter x length)		5.7 x 40mm	5.7 x 40mm	10 x 25mm	18 x 88mm

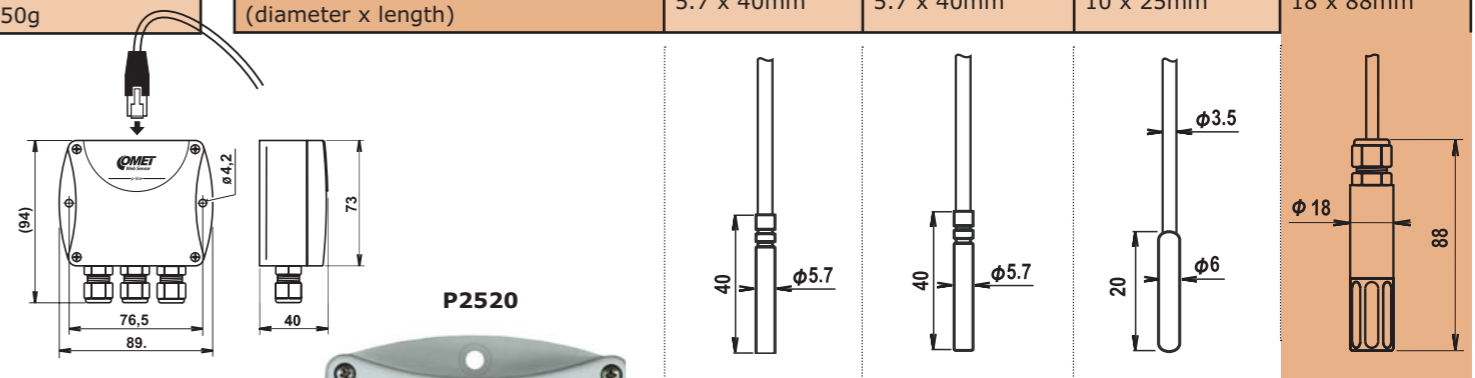
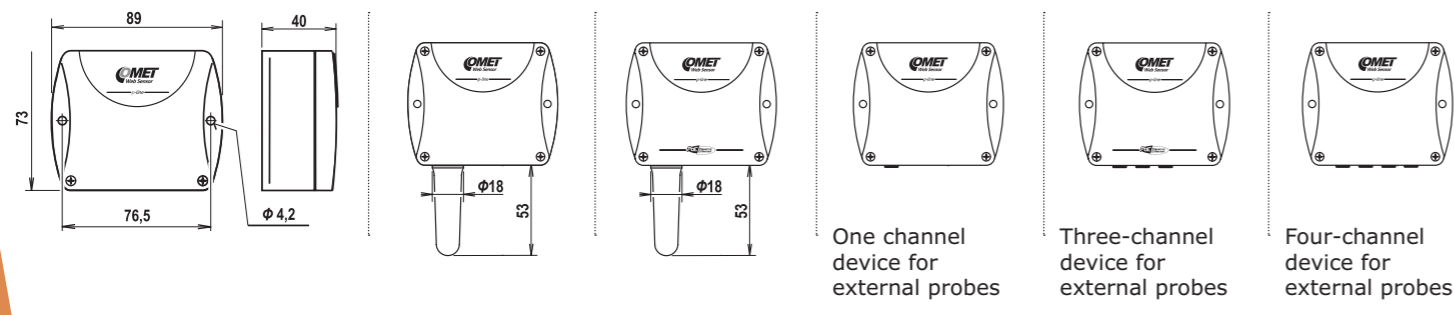

P2520 two channel current loop converter is designed to connect sensors with output 4-20mA / 0-20 mA into Ethernet network. The current signal can be recalculated to physical values measured by the connected sensors. Sensors can be powered directly from the P2520 converter.

- » Measured values can be read by means of Ethernet connection.
- » The instrument may also send a warning message if the measured value exceeds adjusted limit.
- » The device setup can be made by the www interface.

signal input
0 - 20 mA
signal output
0 - 20 mA
power supply



The maximum sum of the lengths of all probes is 40m.

Multi-channel unit allows the combination of several humidity and temperature probes.



Common parameters of sensors with Ethernet and relay outputs

Programmable regulators with Ethernet connection are designed to measure temperature and relative humidity of air, to measure concentration of CO₂ in the air, to signal alarms and control external devices. Regulators can be used in a chemically non-aggressive environment. Measured values are according to device type. Devices with relative humidity measurement can show one of computed values: dew point temperature, absolute humidity, specific humidity, mixing ratio and specific enthalpy. Temperature units are °C or °F. The CO₂ concentration is measured using the maintenance free sensor. The unique patented auto-calibration procedure compensates ageing of the measuring element and guarantees outstanding high reliability and long-term stability.

The sensors are equipped with two relay outputs for alarm indication or control of external devices. Each relay can be assigned to any input value, set up the comparing limit, delay, hysteresis and audible alarm. As an option you can remotely change its status via Modbus communication protocol. Sensors are also equipped with three binary inputs for detection of two-state signals, e.g. flood detection, smoke detection, door contacts and so on.

The device can be used to check measured values. In case of going over the limits set up by the user it can send a warning message to the user's chosen destination.

The device is internally divided into two blocks, the first one takes care of measuring and output relays. It is possible to set up these parameters directly from the keyboard or from the free to download program TSensor. This software can be downloaded from www.cometsystem.cz. The second block will ensure all Ethernet services. Its configuration can be done by the help of TELNET software or from the free to download program TSensor. Warning, this set up cannot be changed by the device's own keyboard.

- Relay outputs**
Two relay output for alarming or external device control. It is possible to assign any input value to each relay. Relay can be remotely controlled using ModbusTCP communication protocol.
- Binary inputs**
It is possible to read three binary inputs statuses for detection of two-state events - e.g. smoke, water leak detectors, door contact. Supported binary inputs: dry contact, open collector or two-state voltage signal.
- Acoustic alarms**
Acoustic signalisation can be activated after exceeding set limits. Alarm can be confirmed (deactivated) from the device keyboard.
- WWW server**
Current values are available via embedded web server. Design of the web pages can be changed according to user requirements.
- Email**
Warning emails are sent when measured value exceed selected limits. SMTP authentication is supported, but SSL not.
- History export to CSV**
History values can be exported for next processing by the CSV file. CSV file can be processed inside spreadsheet application like Microsoft Excel or OpenOffice Calc.
- ModbusTCP protocol**
Modbus protocol for communication with SCADA systems or third party software. Device use version of Modbus TCP protocol.
- SNMP protocol**
SNMP version 1 protocol for IT infrastructure. Using SNMP protocol you can read actual measured values, alarm statuses and alarm parameters. MIB tables with OID description are available.
- SNMP Trap**
SNMP Trap for IT infrastructure. The device allows sending Traps to selected Trap receiver server. Traps are sent in case of alarm on channel or at error states.
- SOAP protocol**
The device allows to send currently measured values via SOAP v1.1 protocol. The device sends values in XML format to the web server. The advantage of this protocol is that communication is initialized by the device side. Therefore it is not necessary to use port forwarding.
- Syslog protocol**
Syslog protocol for IT infrastructure monitoring systems. The device allows sending text messages to selected Syslog server. Messages are sent in case of alarm on channel or at error states.
- SNTP protocol - time synchronization**
Time synchronisation with SNTP server. Actual time is shown at web pages and is necessary for timestamps inside CSV files.

Applications

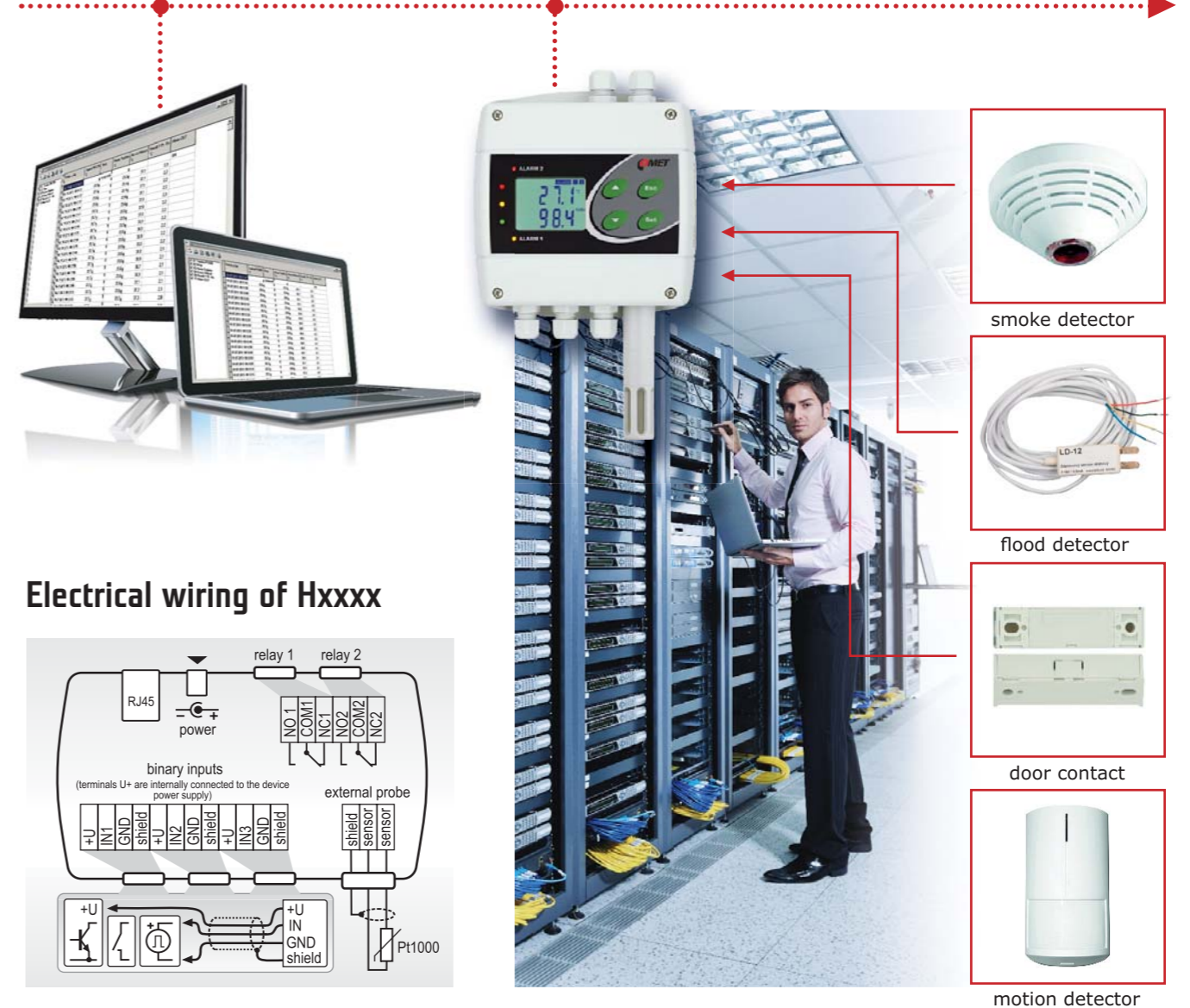

Electrical wiring of Hxxxx

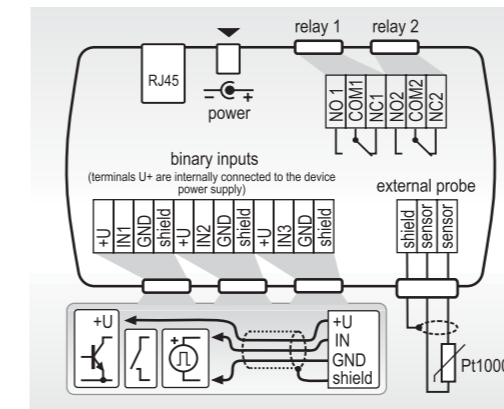

Electrical wiring of HxxxxR

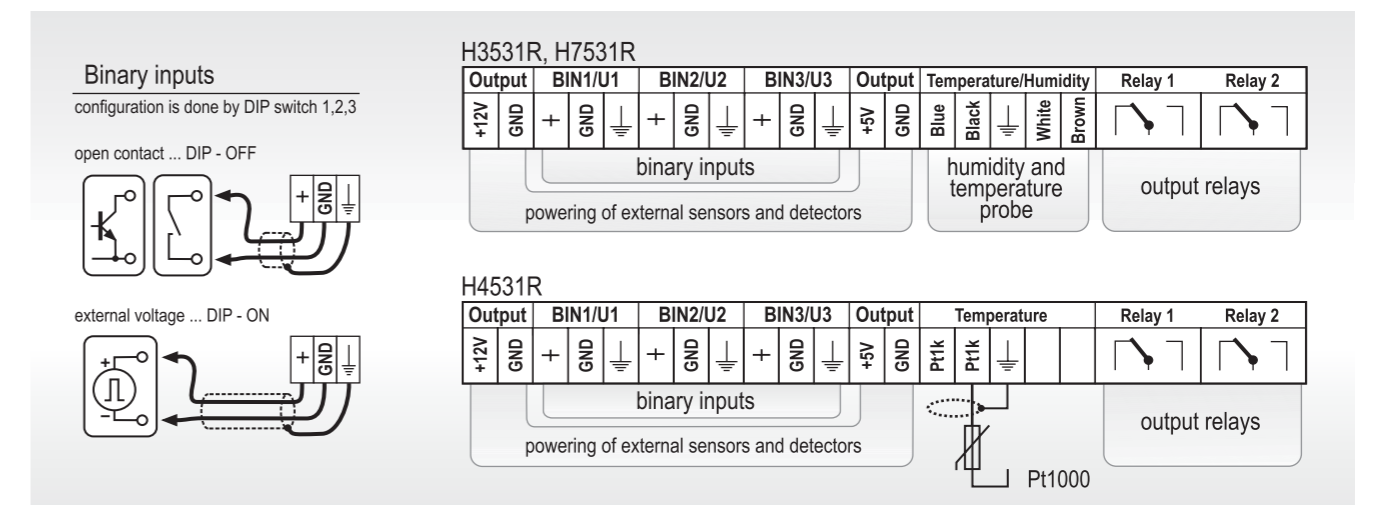



Sensors of temperature, relative humidity, atm. pressure, CO₂ with Ethernet and relay outputs

Common parameters:

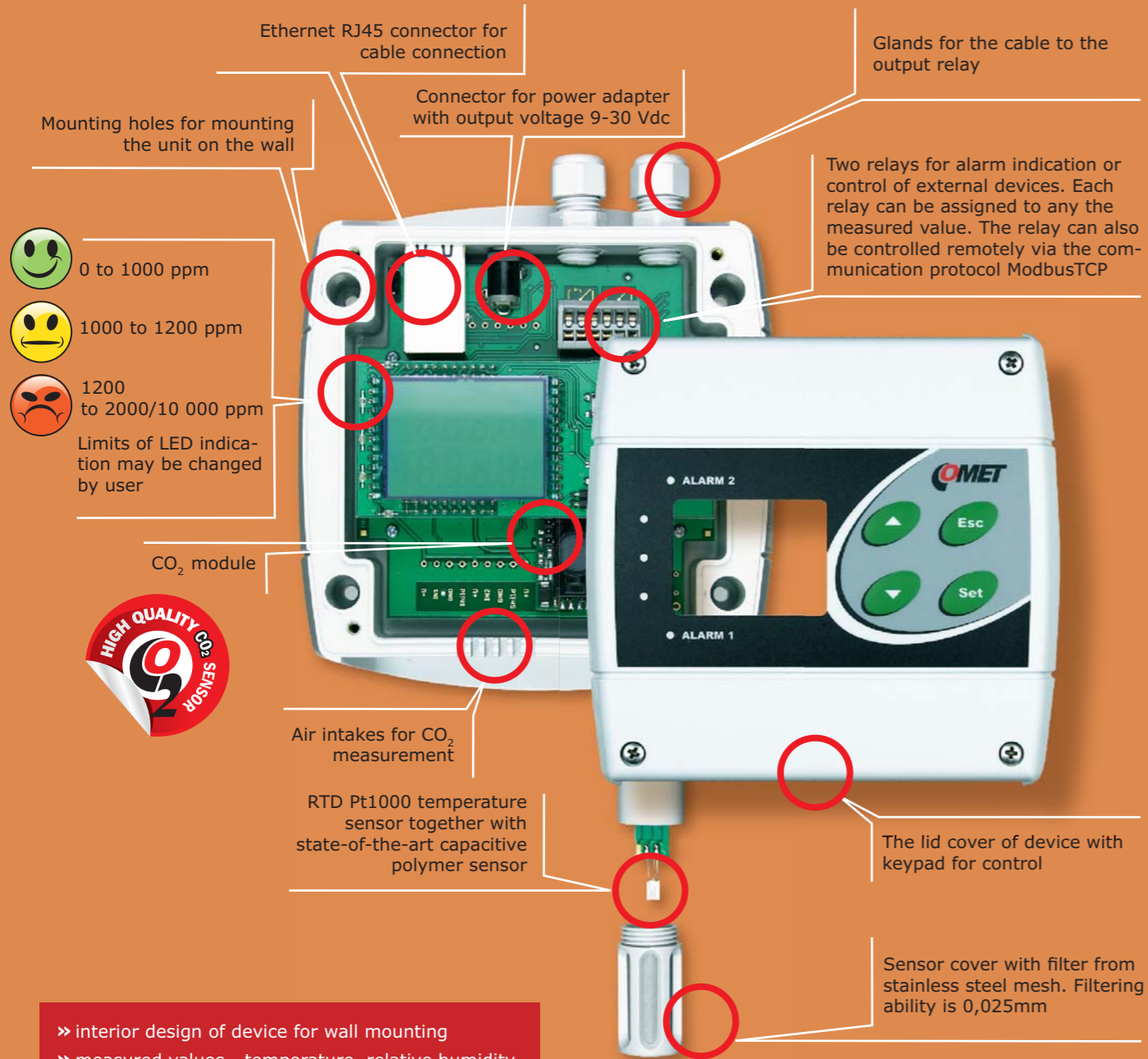

- 0 to 1000 ppm
 - 1000 to 1200 ppm
 - 1200 to 2000/10 000 ppm
- Limits of LED indication may be changed by user



- » interior design of device for wall mounting
- » measured values - temperature, relative humidity, atmospheric pressure, CO₂, computed values
- » traceable calibration certificate with traceability with EN ISO/IEC 17025

Sensor models:

MEASURED VALUES	unit designation*
temperature + 3 binary inputs	H0530, H4531
temperature + relative humidity + 3 binary inputs	H3530, H3531, H3531P
temperature + relative humidity + atm. pressure + 3 binary inputs	H7530, H7531
CO ₂	H5521, H5524
CO ₂ + relative humidity + temperature	H6520

* Please see page 18 - 19 for sensor specification

Common parameters:

...into 19" rack

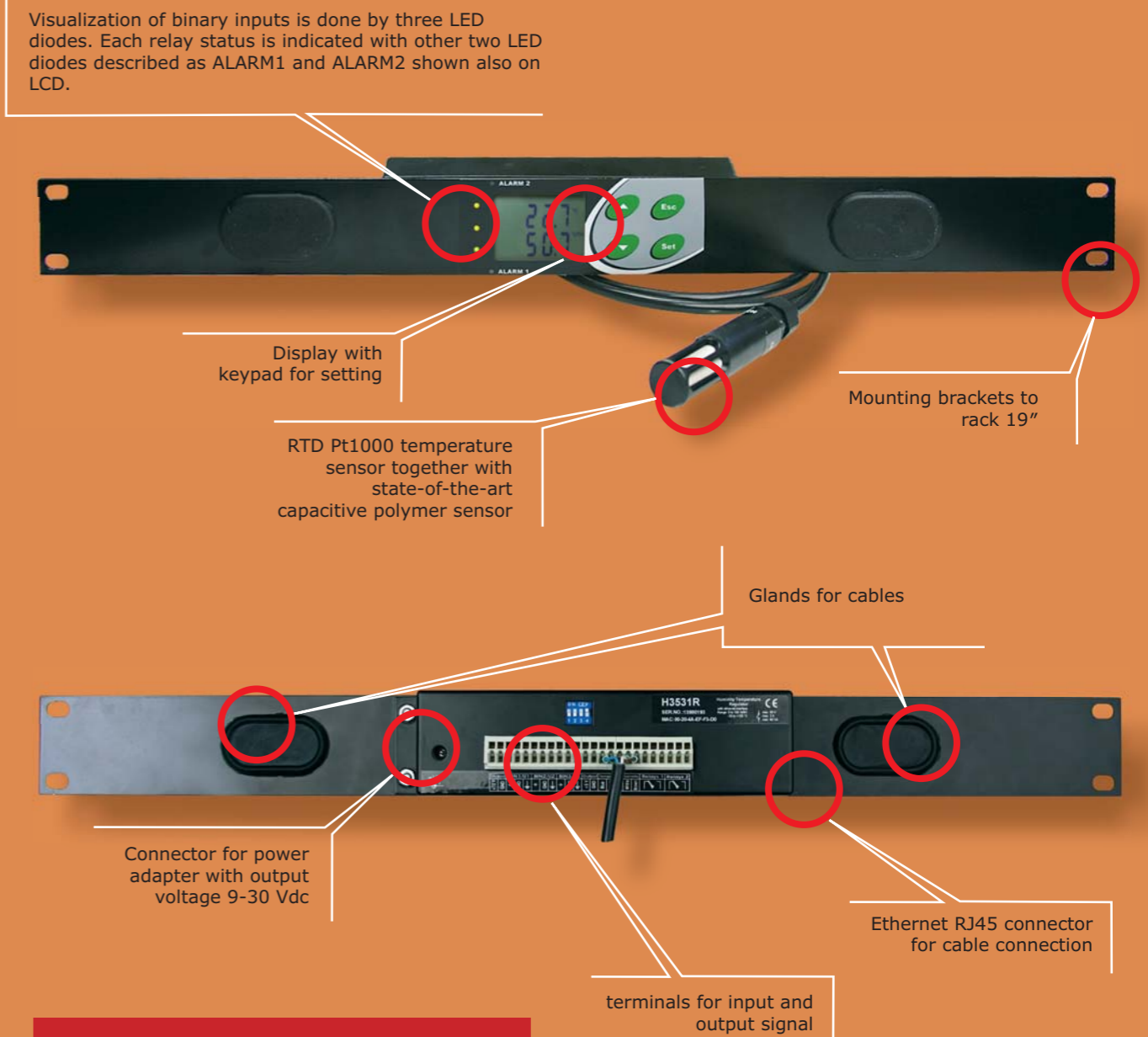

- » designed for 19" rack mounting
- » measured values - temperature, relative humidity, atmospheric pressure, computed values
- » traceable calibration certificate with traceability with EN ISO/IEC 17025

Sensor models:

MEASURED VALUES	unit designation*
temperature + 3 binary inputs	H4531R
temperature + relative humidity + 3 binary inputs	H3531R
temperature + relative humidity + atm. pressure + 3 binary inputs	H7531R

* Please see page 19 for sensor specification



Sensors with Ethernet and relay outputs and their specification

Measured values		Temperature		Temperature, relative humidity			Temperature, relative humidity, atm. pressure		Temperature, relative humidity, CO ₂		Temperature	Temperature, relative humidity	Temperature, relative humidity, atm. pressure		
SENSOR MODEL		H4531	H0530	H3530	H3531	H3531P	H7530	H7531	H6520	H5524	H5521	H4531R	H3531R	H7531R	
temperature	range	-200 to +600°C	-30 to +80°C	-30 to +80°C	-30 to +105°C			-30 to +80°C	-30 to +105°C	-30 to +80°C	-	-200 to +600°C	-30 to +105°C	-30 to +105°C	
	accuracy	±0.2°C without temp. probe	±0.4°C	±0.4°C	±0.4°C			±0.4°C	±0.4°C	±0.4°C	-	±0.2°C without temperature probe	±0.4°C	±0.4°C	
relative humidity**	range	-	-	0 to 100%RH	0 to 100%RH			0 to 100%RH	0 to 100%RH	0 to 100%RH	-	-	0 to 100%RH	0 to 100%RH	
	accuracy	-	-	±2.5 %RH	±2.5 %RH			±2.5 %RH	±2.5 %RH	±2.5 %RH	-	-	±2.5 %RH	±2.5 %RH	
atmospheric pressure**	range	-	-	-	-			600 to 1100 hPa	600 to 1100 hPa	-	-	-	-	600 to 1100 hPa	
	accuracy	-	-	-	-			±1,3 hPa	±1,3 hPa	-	-	-	-	±1.3 hPa	
CO ₂ ***	range	-	-	-	-			-	-	0 to 2000 ppm*	0 to 2000 ppm*	0 to 10 000 ppm	-	-	
	accuracy	-	-	-	-			-	-	± (50ppm+2% of measured value)		± (110ppm +5% of measured value)	-	-	
relay output max. switching voltage, current, power		50V, 2A, 60VA	50V, 2A, 60VA	50V, 2A, 60VA	50V, 2A, 60VA			50V, 2A, 60VA	50V, 2A, 60VA	50V, 2A, 60VA	50V, 2A, 60VA	50V, 2A, 60VA	50V, 2A, 60VA	50V, 2A, 60VA	50V, 2A, 60VA
computed humidity values		NO	NO	YES	YES			YES	YES	YES	NO	NO	YES	YES	
supply voltage		9-30 V	9-30 V	9-30 V	9-30 V			9-30 V	9-30 V	9-30 V	9-30 V	9-30 V	9-30 V	9-30 V	
recommended calibration interval		two years	two years	one year	one year			one year	one year	one year	five years	five years	two years	one year	
protection class of the case with electronics		IP40	IP40	IP40	IP40			IP40	IP40	IP30	IP30	IP30	IP30	IP30	
protection class of the sensor cover		-	-	IP40	IP40			IP40	IP40	-	-	IP65	-	IP40	
temperature operating range of the case with electronics		-30 to +80°C	-30 to +80°C	-30 to +80°C	-30 to +80°C			-30 to +80°C	-30 to +80°C	-30 to +60°C	-30 to +60°C	-30 to +80°C	-30 to +80°C	-30 to +80°C	
temperature operating range of the measuring element		-	-	-30 to +80°C	-30 to +105°C			-30 to +80°C	-30 to +105°C	-30 to +80°C	-	-40 to +60°C	-	-30 to +105°C	
humidity operating range without condensation		0 to 100%RH	0 to 100%RH	0 to 100%RH	0 až 100%RH			0 to 100%RH	0 to 100%RH	0 to 95%RH	5 to 95 %RH	0 to 100%RH	0 to 100%RH	0 to 100%RH	
barometric pressure operating range		-	-	-	-			up to 2.5MPa	-	-	850 to 1100hPa	850 to 1100hPa	850 to 1100hPa	-	
mounting position		any position	cover downwards	cover downwards	any position			cover downwards	any position	cover downwards	connectors upwards	any position	any position	any position	
storage temperature range		-30 to +80°C	-30 to +80°C	-30 to +80°C	-30 to +80°C			-30 to +80°C	-30 to +80°C	-40 to +60°C	-40 to +60°C	-40 to +60°C	-30 to +80°C	-30 to +80°C	
electromagnetic compatibility		EN 61326-1	EN 61326-1	EN 61326-1	EN 61326-1			EN 61326-1	EN 61326-1	EN 61326-1, EN 55011	EN 61326-1, EN 55011	EN 61326-1, EN 55011	EN 61326-1	EN 61326-1	
weight		340g	340g	360g	410(450,530)g	460(500,580)g	360g	410(450,530)g	350g	330g	420 (450, 510)g	1025g	1090g	1090 (1130,1210)g	

* Custom range 10000 ppm for an extra fee

** accuracy of relative humidity in range 5% to 95% and of atmospheric pressure at 23°C

*** accuracy of CO₂ concentration of measurement at 25°C and 1013 hPa

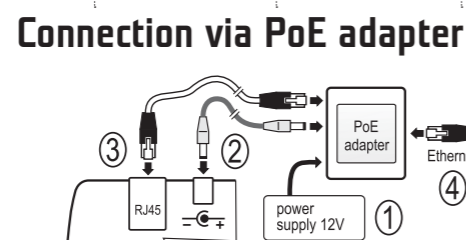
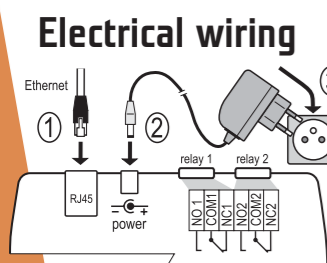
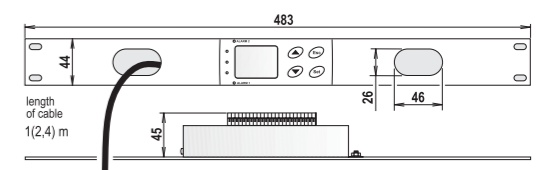
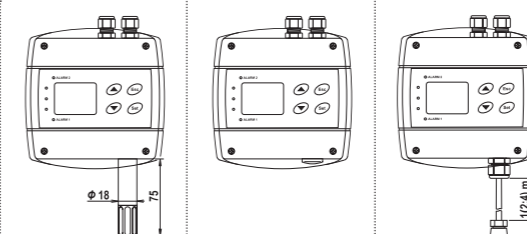
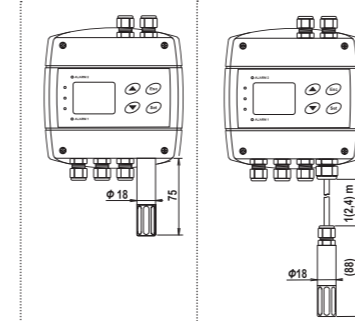
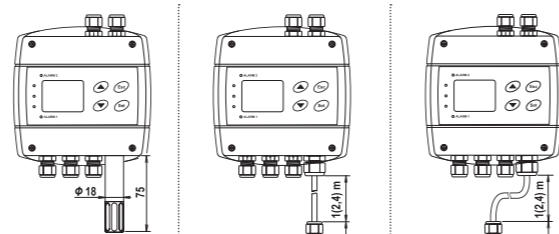
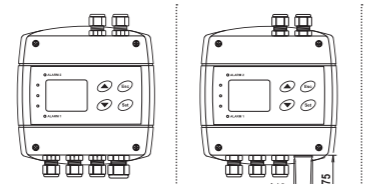
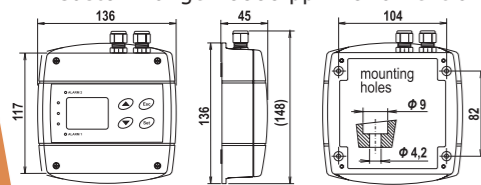

Computed values

Specific humidity
Accuracy: ±2.1 g/kg at ambient temperature T < 35 °C
Range: 0 to 550 g/kg

Absolute humidity
Accuracy: ±1.5 g/m³ at ambient temperature T < 25 °C
for more details see manual
Range: 0 to 400 g/m³

Dew point temperature
Accuracy: ±1.5°C at ambient temperature T < 25°C and relative humidity RH > 30%, for more details see manual
Range: -60 to +80 °C (-76 to 176 °F)

Mixing ratio
Accuracy: ±2 g/kg at ambient temperature T < 35 °C
Range: 0 to 995 g/kg

Specific enthalpy
Accuracy: ± 3kJ/kg at ambient temperature T < 25 °C
Range: 0 to 995 kJ/kg



Optional accessories

Mounting accessories



PP90 - Right-angled stainless steel flange.



PP4 - plastic flat circular flange



SH-PP - Flow chamber for compressed air measurement up to 25 bars - stainless steel DIN 1.4301 inlet and outlet connection - G1/8 thread humidity probe connection - G1/2 thread screw-coupling not included.

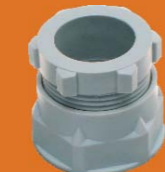

SP004 - Plastic gland for direct mounting of the humidity probe to a 29 mm diameter hole.

The probe for measuring the moisture of compressed air should be placed directly on the pressure pipelines to achieve higher measurement accuracy and faster response times. But there are cases where such placement is not possible. The reason is the high air speed, high temperature, high pollution, small diameter pipes, etc. Such situation can be solved by placing the probe into the flow measuring chamber.

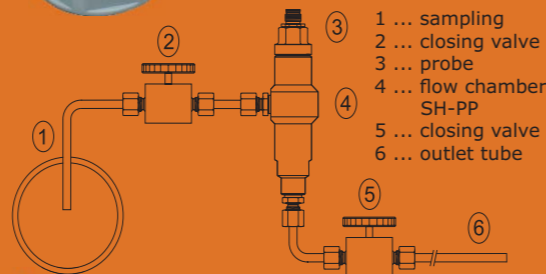

MP047 Universal holder for probes for easy mounting to rack 19".



MP046 Universal holder for P8xxx and Tx5xx Web Sensors for easy mounting to rack 19".



Protection of sensors



F8000 - Solar radiation shield for transmitters with T+RH probe on a cable.



F5200 - Grey sensor cover with filter from stainless steel mesh, filtering ability 0.025mm.

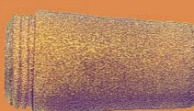

F5200B - Black sensor cover with filter from stainless steel mesh, filtering ability 0.025mm.

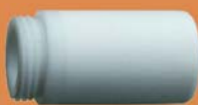

F5300 - Teflon (PTFE) sensor cover (white colour), with increased resistance against splashing water, non-absorbent surface, does not rust. Porous size 25µm. Temperature range -40°C to +125°C.

F0000 - Sintered bronze sensor cover. Filtering ability 0.025mm.

Detectors



SD-280 Optical smoke detector.



SP008 AC voltage presence sensor.



LD-12 Water leakage detector.



JS-20 - P.I.R. motion detector is for interior protection. It detects object movement having human body temperature. The signal from the sensor is electronically analyzed. This ensures that the detector provides excellent sensitivity and false alarms are basically eliminated.



SA200A Magnetic door contact for detecting opening / closing windows, doors and so on.

Power supplies



TL-POE - Power over Ethernet (PoE) splitter for connection of sensors and Web Sensors which does not support PoE.

PoE switch IEEE 802.3af compatible



CAT5 UTP cable (Power & Data)



Power Cable (+12 V)

PoE splitter TL-POE10R



T3510



A1515 Switching power supply unit for Ethernet transmitters Tx5xx, Hx5xx.

A1825 Switching power supply unit for Web Sensors P8xxx and Tx6xx.

Calibration



MD046 - Vessel for adjustment and calibration of humidity.

HM023 - Set of humidity standards 10% RH with 5 application pads.

HM024 - Set of humidity standards 80% RH with 5 application pads.

Communication



TP-LINK-TL Wi-Fi adapter for wireless connection of transmitter or data logger to Ethernet network. Including replaceable antenna and power adapter. Long term proved operation.

KIT-GSM-W - If GSM modem is connected to your computer or server where Comet database is installed then you get the 24-hour surveillance of critical events. This inexpensive service can prevent costly damage to health, goods and property.





Comet Database - Monitoring of temperature, relative humidity, atmospheric pressure and CO₂ by means of Ethernet

For users of Web Sensors a solution for data collection to one central database is available. It is based on MS SQL or MySQL. Software system is suitable for users who want to analyze data from multiple loggers MS or other products of Comet System.

Comet Database offers:

- data stored in one place and accessible with Comet Database Viewer
- to provide data in table and graph
- to print and export data
- alarms via SMS texts and emails
- acoustic and visual signalization of alarms
- compatibility with all Comet System devices and 3rd party devices
- displaying of online values

TSensor
Free configuration software for sensors with Ethernet output.

SensorReader
Freeware software for displaying and logging data from one COMET sensor. The software stores measured values to a CSV file which can be processed in MS Excel. The software allows acoustic signalization of exceeded limits or sensor failure.

What does Comet Database offer?

- » 24 hours supervision
- » storage place for your data
- » simple and clear access to your measured values
- » storage place for all Comet System devices
- » alarm SMS texts and e-mails



Comet Database Viewer
Each purchased Comet Database already contains one licence of Database Viewer. This low cost browser enables several clients to view database from different places on internal network or internet. Other viewer licences can be purchased separately for other users of Comet Database.

If you already have Comet database there is no need to purchase any additional software for running your Web Sensors with Comet Database.

Comet Database also exist in 30 days trial version. So you can test it without any worries.

"get the  *fever"*



COMET SYSTEM, s.r.o.
1.maje 1220
756 61 Roznov pod Radhostem
CZECH REPUBLIC
Tel: +420-571653990
Fax: +420-571653993
E-mail: info@cometsystem.cz
www.cometsystem.cz
GPS Location:
49°27'39.94"N
18°7'51.295"E