

205 Westwood Ave, Long Branch, NJ 07740
Phone: 866-94 BOARDS (26273) / (732)-222-1511
Fax: (732)-222-7088 | E-mail: sales@touchboards.com

Product data sheet: Tabletops

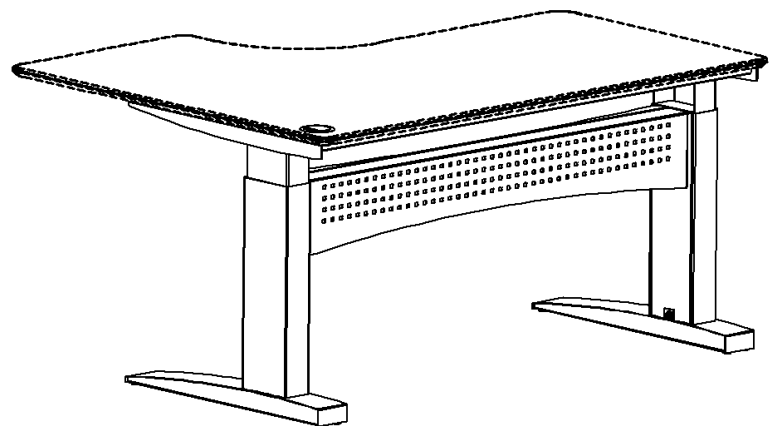
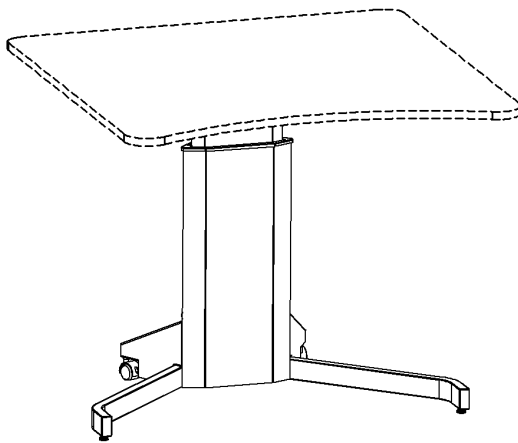
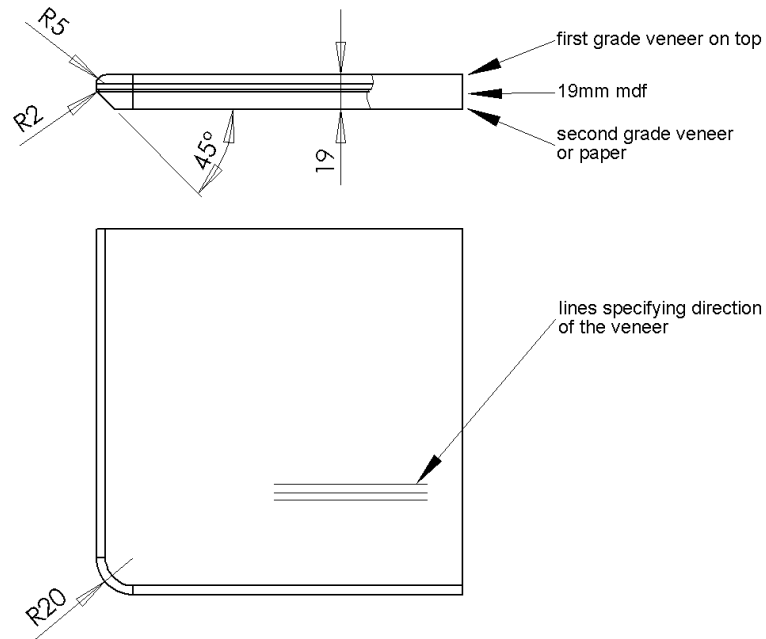

Table of contents

Technical specifications, veneer tabletops	page 3
Technical specifications, melamine tabletops	page 4
Veneer specifications	page 5
Melamine specifications	page 5
Environmental perspectives	page 6

Technical specifications, veneer tabletops

Measures, tabletops for 1 column frames



Measures, tabletops for 2 and 3 column frames

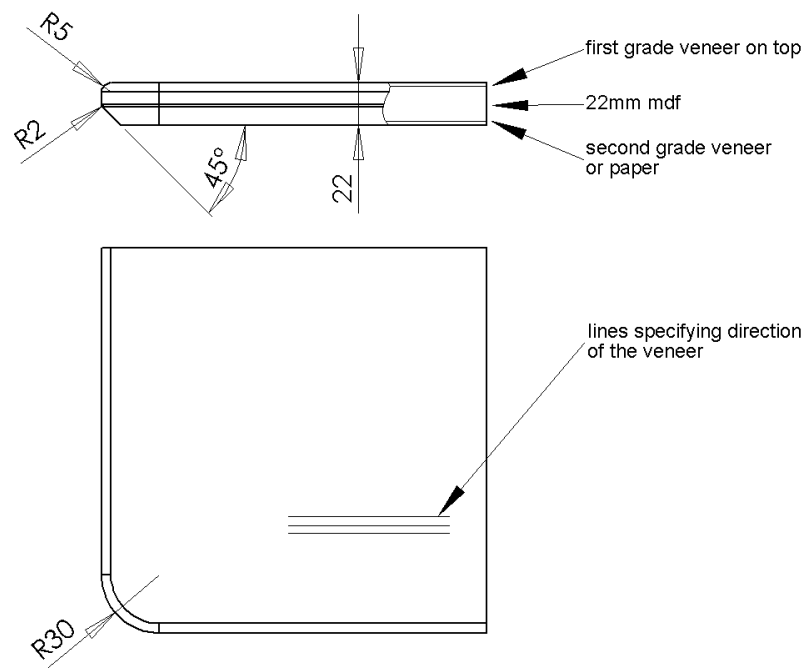

Technical specifications, melamine tabletops

Measures, tabletops for 1 column frames

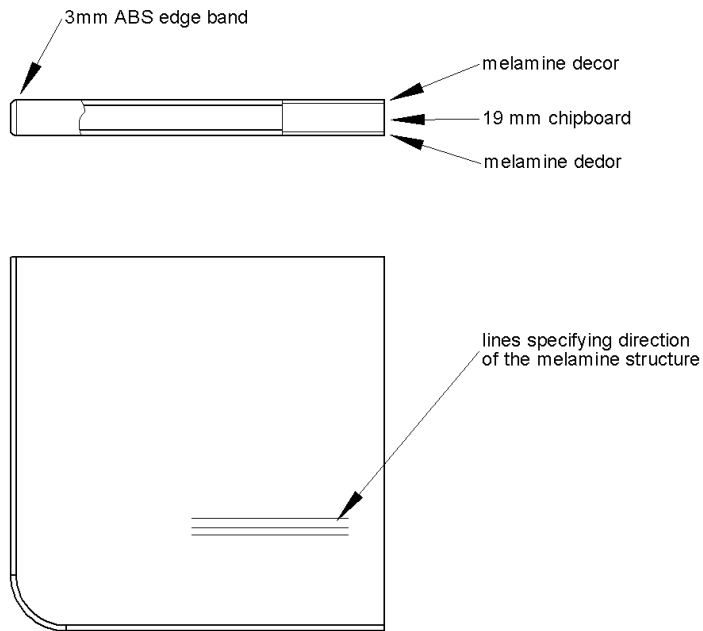

Measures, tabletops for 2 and 3column frames

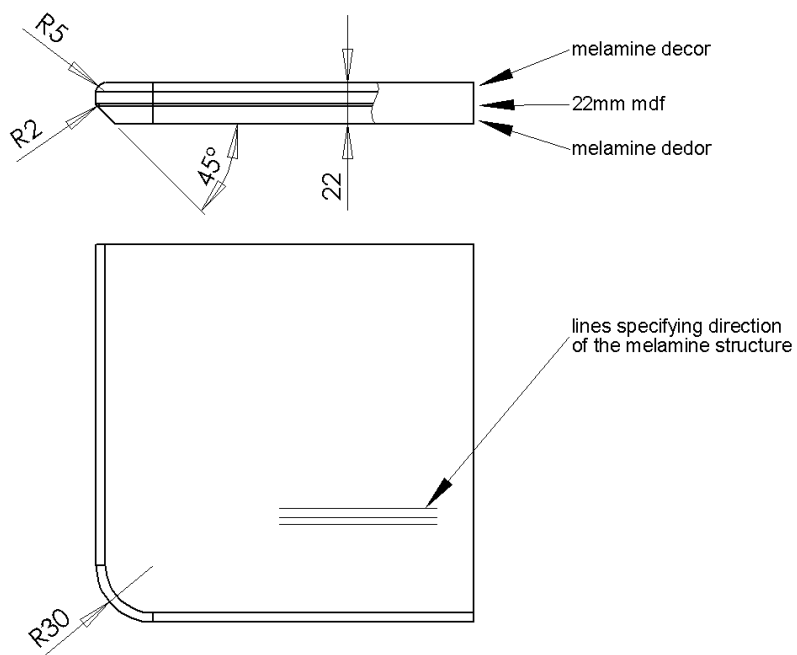

Veneer specifications

ConSet have 4 different kind of veneers in range.



Beech



Maple



Cherry



Oak

The veneers used for ConSet tabletops are approx. 0,6mm in thickness and have an average width before sewing of approx. 70mm. By using references of good and bad qualities the producer of the veneer know exactly what is acceptable using for a ConSet tabletop.

Melamine specifications

ConSet have 3 different kind of melamine in range.



The melamine is 1,0mm in thickness and have a slightly structured surface. All melamine's are bought from one of the leading melamine producers, Kronospan in Germany, which gives the safety of having a uniform quality.

Environmental perspectives

ConSet do their up most to protect the environment and do this by making sure, that the suppliers of tabletops have the following approvals:

FSC certification

This certification specifies that "The facility(s) and product(s) have been independently certified by Scientific Certification Systems (SCS) in accordance with the rules of the Forest Stewardship Council A.C. (FSC). This product(s) has been harvested from forests that meet stringent environmental, social and economic standards.



Determination of emissions from solid wood elements

All the MDF, particleboard and plywood used in the range of ConSet tabletops have an emission of formaldehyde that is below the maximum value for the E1 approval. The determination is made according to EN 717-1, 1998.

Lacquer used for ConSet tabletops

The veneer on ConSet tabletops are finished with lacquer. Only the most environmental protecting UV-hardening lacquer is used. The lacquer is added using roller.

The edges of the tabletops also is done using a water based lacquer. The lacquering is done by spraying.

Touchboards

205 Westwood Ave, Long Branch, NJ 07740

Phone: 866-94 BOARDS (26273) / (732)-222-1511

Fax: (732)-222-7088 | E-mail: sales@touchboards.com