



Display not included.

Flat Panel Cart
JOLLi

Features and Benefits

- Suitable for 55" – 84" Flat Panel with max. weight of 330lbs
- **Universal display mount included.** Max. VESA 800 x 600.
- 20" of smooth height adjustment via wired remote.
- Side handles, storage bins & laptop shelf in color baby blue
- UL-certified electric lift.
- Integrated cable management.
- Fits through standard doorways.
- ADA compliant.
- 3 year warranty on motorized components. 5 years frame warranty.
- UPS shippable. Quick and easy assembly.



2 large storage bins & large sturdy casters



Large handles & rotating laptop shelf

The ConenMounts **JOLLi** Flat Panel Cart is the next generation of Flat Panel carts for education. The cart allows for the display to be smoothly raised & lowered and to be moved from classroom to classroom, connecting teachers and students with the latest technologies.

Designed for rugged environments the K12 cart features a sturdy metal base with heavy-duty casters. The V-shape base provides stability and ensures easy access for students in wheelchairs. Large ergonomic handles on each side of the display aid mobility and help protect the display in transport.

Safely built into the aluminum center column of the cart is the UL certified actuator which offers 20" of smooth height adjustment. With a push of a button the display can be adjusted so that teacher and children can interact with the display.

Flat Panel Cart
JOLL 

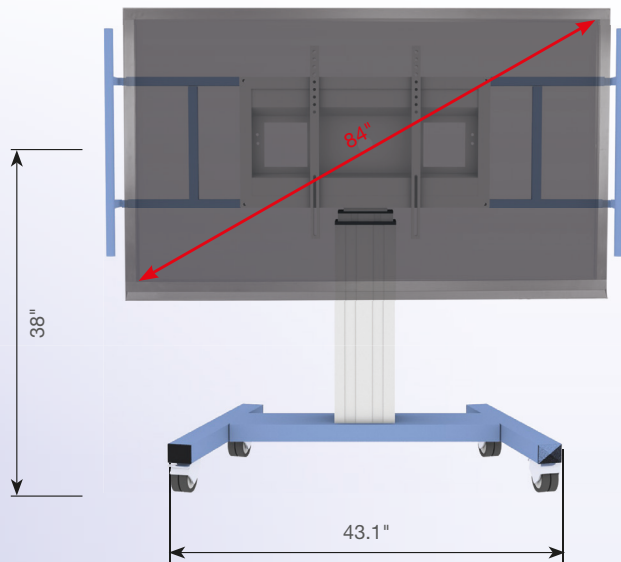

Lowest position – distance from floor to center of screen

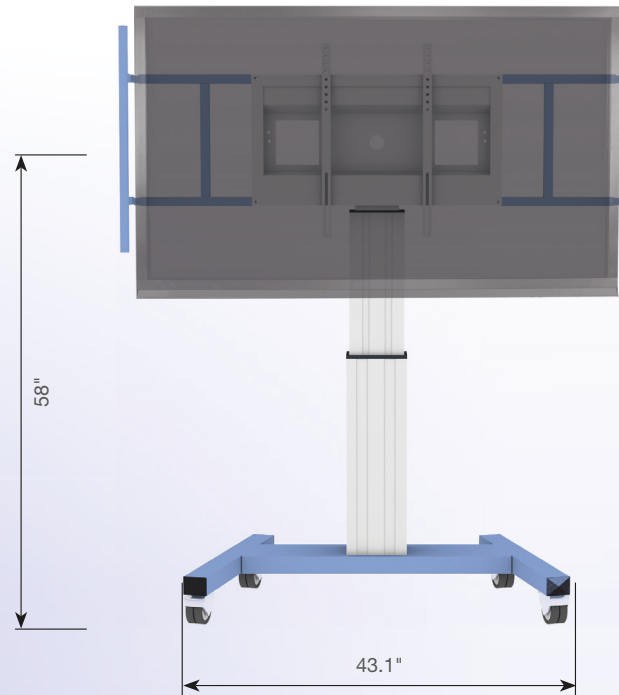

Upper position – distance from floor to center of screen

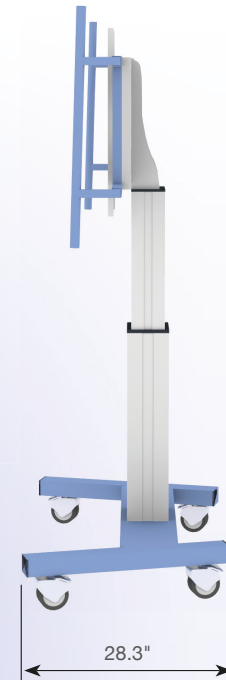

Upper position – side view



www.conenmounts.com

CONEN[®]
mounts

Distributed by:

Stirling Communications Supply
29 Poplar Drive
Stirling, NJ 07980

T: (908) 604-9360
E: DPilar@stirlingcomm.com