

SCETTA

Mobile cart with motorized height adjustment & tilt

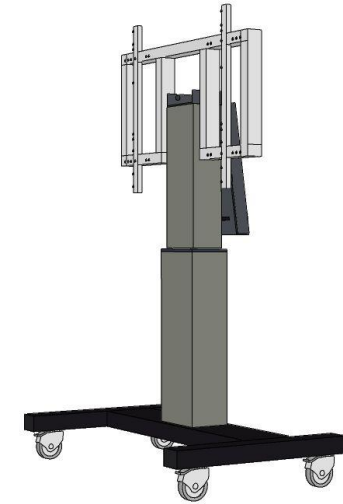

Item no.:	SCETTA
Product description	mobile stand with motorized height adjustment and tilting display frame. For 42"-70" (interactive) Flat-Panel Display
Consists of:	AFSCETTA tilting display mount CCET50WBL center column MSTSCETA mobile stand
Weight capacity:	330 lbs.
Shipping weight:	154 lbs.

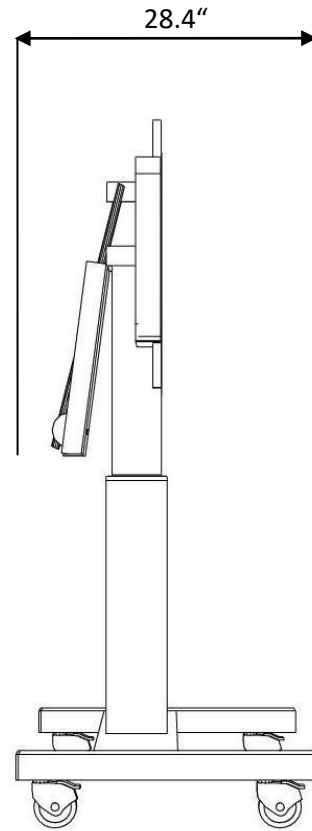
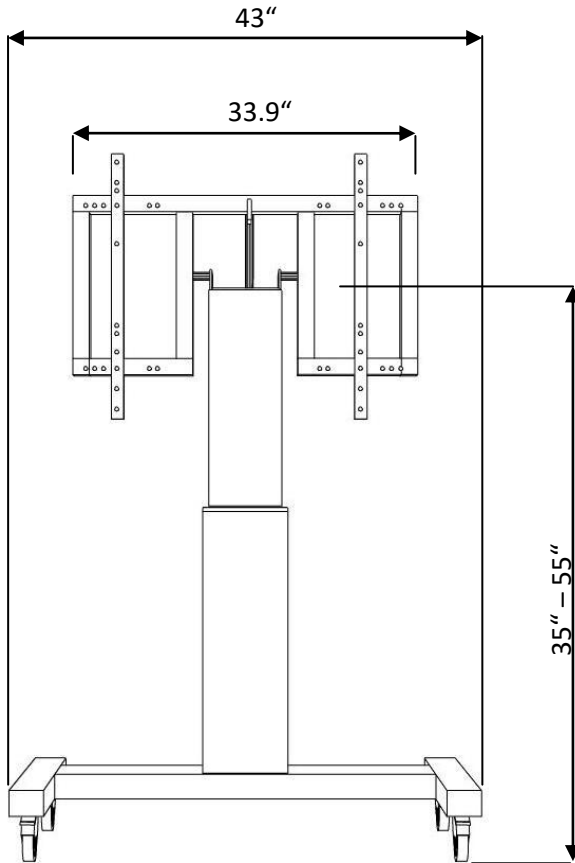