

CONEN[®] *mounts*



PRODUCT GUIDE

Education | Corporate | Hospitality | Training

INTRODUCTION

Index	2
Taking interactivity to a higher level	3
Masters in Motorized Mounts	4

MOUNTING SOLUTIONS FOR FLAT PANEL DISPLAYS

Wall mounted solutions

Motorized wall mount for flat panel up to 70"	6
Motorized wall mount for flat panel up to 84"	8

Mobile solutions

Motorized mobile stand for flat panel up to 70"	10
Motorized mobile stand for flat panel up to 84"	12
JOLli education flat panel cart	14
Height & tilt adjustable mobile Flat Panel Stand	16
Height & tilt adjustable Flat Panel Cart for K-12	18

Miscellaneous

Motorized mount and stand with XL display mount	20
Fixed height Flat Panel mounts and stands	22
Over the board mount	24
SMART kapp 42 stand	26

MOUNTING SOLUTIONS FOR INTERACTIVE WHITEBOARDS

Wall mounted solutions

Motorized wall mount for IWB	28
------------------------------	----

Mobile solutions

Motorized mobile stand for IWB	30
--------------------------------	----

MOUNTING SOLUTIONS FOR INTERACTIVE PROJECTORS

Mobile solutions

WorkITdesk interactive table	32
WorkITdesk DeLuxe interactive & dry erase table	34
Motorized mobile board system	36

Wall mounted solutions

Motorized board system for Interactive projectors	38
---	----

DELUXE PROJECTION BOARD

40

ACCESSORIES

42

ABOUT CONEN MOUNTS

46

Since the introduction of interactive technologies about a decade ago, teaching methods have begun to change. A clear shift is noticeable from the traditional teacher-centered education towards a student-centered approach, in which group work is encouraged and students learn through interaction and collaboration. This changing approach requires more mobile and flexible teaching solutions.

ConenMounts mounting solutions give everyone the opportunity to participate. The height adjustable mounts allow for the board or display to be smoothly raised or lowered and provide teachers and students an optimum ergonomic and writing position.

WHY HEIGHT ADJUSTABLE?

One school – many teachers and children – different ages – various heights

Our system is height adjustable

ONE FOR ALL



Whether wall mounted or mobile, ConenMounts adjustable solutions allow for everyone to participate. With up to 28" of vertical height adjustment, even those in early grades or in wheelchair can access the board. For small group learning activities or for situations that require a portable solution, ConenMounts offers a variety of height adjustable mobile stands.

ConenMounts solutions are developed to help schools transition from traditional to interactive technologies.

Our mounts accommodate any interactive technology, whether interactive projector, interactive whiteboard or flat panel display and allow for future upgrades. This makes ConenMounts a long-term investment, allowing for budget to be freed-up and spent somewhere else.

If you are ready to take interactivity to a whole new level, complement your technology with a ConenMounts adjustable mount.

With over 40 years of experience in manufacturing height adjustable solutions, Conen has focused on its range of motorized mounts in the past couple of years. Motorized mounts offer several distinct advantages over spring operated or counterbalanced solutions:



Compatible with any interactive technology

ConenMounts motorized solutions allow for a max. 330 lbs. weight load. The systems work with any interactive technology, whether board and projector or heavy 84" display.

Counter weight or spring tension mechanisms come with a specific set of weights or springs to balance the weight of the system. Any change in weight load, for example by adding speakers, or if a projector is being exchanged, may cause for the system to not work properly.

With a ConenMounts motorized solution, weight load changes are not an issue. Up to a max. 330 lbs. weight load, our mounts will allow for anything to be added.



Maintenance free

Another benefit of a motorized solution is that the system does not require any maintenance.

Whereas a spring tensioned mechanism tends to lose its tension over time and requires for a system to be rebalanced, a motorized solution is maintenance free.



ADA compliant

The Americans with Disabilities Act (ADA) ensures access to the built environment. To prevent hazards to people with vision impairments, the safety standards limit the protrusion of objects into circulation paths.

These standards also address the accessibility and maneuvering clearance of elements, such as displays, so that all users can take a full advantage of all their features.

All Conen's mobile and wall mounted solutions comply with the requirements of the ADA Standards.





Future proof



The modular concept of ConenMounts solutions allows for easy upgrades to future technologies or requirements.

A wall mounted system can easily be converted into a mobile solution, simply by adding a mobile base.

And a motorized solution that is purchased now for use with board and projector can, sometime in the future, be easily converted into a system for use with Flat Panel Display.

All of this is possible because the heart of the system, the motorized center column, always remains the same.



Safe mounting to stud walls



ConenMounts wall mount solutions are the safest wall mount solutions currently available. Unlike traditional wall mounts where the entire weight load is being supported only by the wall, our center column systems absorb all the weight without any wall reinforcements.

Whether mounted to a solid, brick wall or to a wood stud wall, a Conen Mounts solution safely supports your technology.



Limited life time warranty

ConenMounts products comply with all important international products and safety standards, including UL and CSA.

As a commitment to the quality of its products, Conen backs the range of motorized mounts by a 5 year warranty.

MOTORIZED WALL MOUNT FOR FLAT PANEL UP TO 70"



Classroom technology should not be limited to just a few. With ConenMounts motorized wall mount the display can easily be raised and lowered to give teachers and students of any height the opportunity to participate.

Designed for use with 42" – 70" Flat Panel displays the SCETAWLBOX motorized wall mount features a sheet metal display mount with series of integrated VESA patterns.

The box style design of the mount allows for hardware, such as mini-PC or laptop, to be stored neatly behind the display. The unit offers 20" of smooth height adjustment, provided by the UL-approved actuator that is safely built into the center column. Every wall mount comes standard with 4 leveling feet, a wired remote and 2 wall mount brackets to secure the column to the wall.

For more info on this product scan the QR code



Key features

- Designed for displays up to 70"
- Sheet metal box mount with integrated VESA pattern, up to 600 x 400
- Box allows for hardware to be neatly stowed behind the display
- 20" of vertical travel

Technical drawings

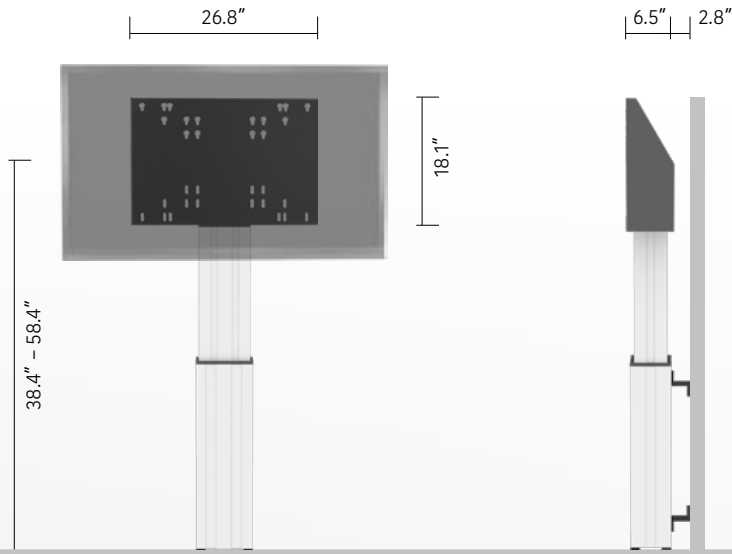

Product Code	SCETAWLBOX
Display range	42" – 70"
VESA pattern	200 x 200 – 600 x 400
Load capacity	275 lbs
Shipping weight	65 lbs
Warranty	5 year



Available accessories

More information on page 42 – 45



- Front shelf
- Side shelf (pictured)
- Floor plate
- Stud wall mounting bracket

MOTORIZED WALL MOUNT FOR FLAT PANEL UP TO 84"



The SCETAWL and SCETA3535 Wall Mounts are designed for Flat Panel Displays up to 84". The units feature a sturdy display mount with integrated cable management and 'pull and release' locking brackets for quick and easy mounting of the display.

The difference between the SCETAWL and SCETA3535 is in the center column; the SCETAWL comes with the standard column that offers 20" of vertical travel,

the SCETA3535 features the new 3-tier column with extended 28" of height adjustment, making it the perfect solution for K-6 or special needs applications.

It provides the best of both worlds; a minimum clearance for accessibility by small children or people in wheelchair and maximum clearance for the teacher to present.

For more info on this products scan the QR code



SCETAWL



SCETA3535

Key features

- Heavy duty mount for 42" – 84" displays
- 'Pull & release' brackets for easy display mounting
- Integrated cable management
- Available with standard 20" travel or extended 28" travel for K-12
- Allows mounting of whiteboard wings

Technical drawings

SCETAWL – 2-tier center column

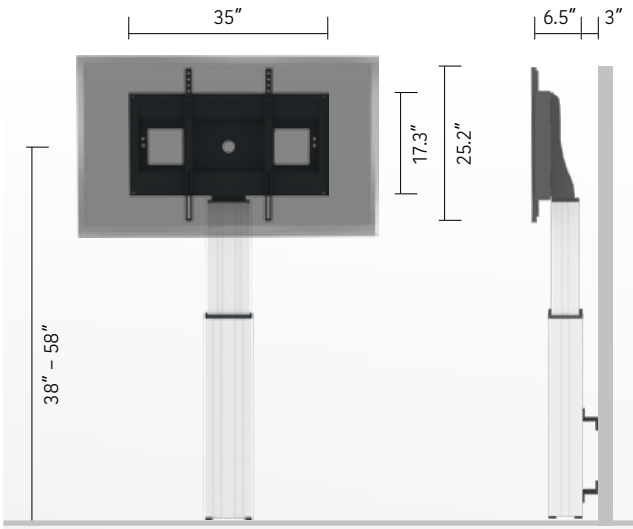

SCETAW3535 – 3-tier center column

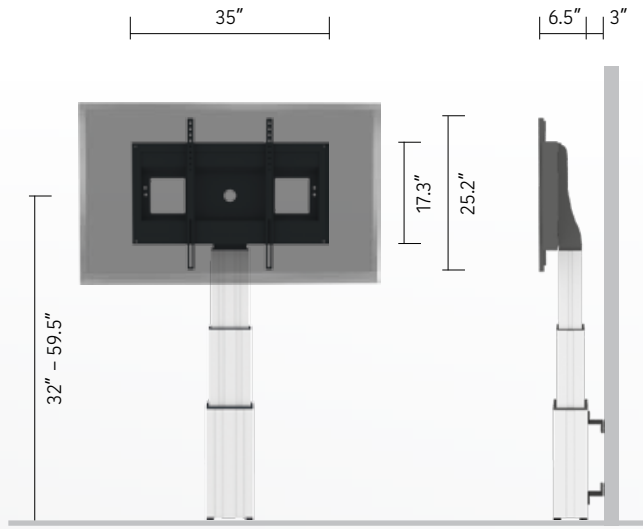

Product Code	SCETAWL	SCETAW3535
Display range	42" – 84"	42" – 84"
VESA pattern	200 x 200 – 800 x 600	200 x 200 – 800 x 600
Load capacity	330 lbs	330 lbs
Shipping weight	75 lbs	83 lbs
Warranty	5 year	5 year



Pull & release locking brackets for easier mounting of display



Levelling feet and 2 wall mounting brackets for optimum stability



Allows for mounting of whiteboard side wings

Available accessories

More information on page **42 – 45**



- Front shelf
- Side shelf
- Floor plate (pictured)
- Side wings
- Stud wall mounting bracket
- VC camera shelf

MOTORIZED MOBILE STAND FOR FLAT PANEL UP TO 70"



For teaching situations that require for a portable solution, ConenMounts offers a variety of mobile stands.

The SCETA VBOX is the entry model mobile stand, featuring the box style display mount and a V-style mobile base. The box mount allows for hardware and cables to be stowed away neatly behind the display.

The black, V-shaped, mobile base fits in with any space and style and enhances the contemporary design of the SCETA mount. Its wide base allows easy access to the display, also for people in wheelchair.

For more info on this product scan the QR code



Key features

- Designed for displays up to 70" and max. VESA 600 x 400
- Sheet metal box mount with VESA pattern
- Box allows for hardware to be neatly stowed behind the display
- 20" of vertical travel

Technical drawings

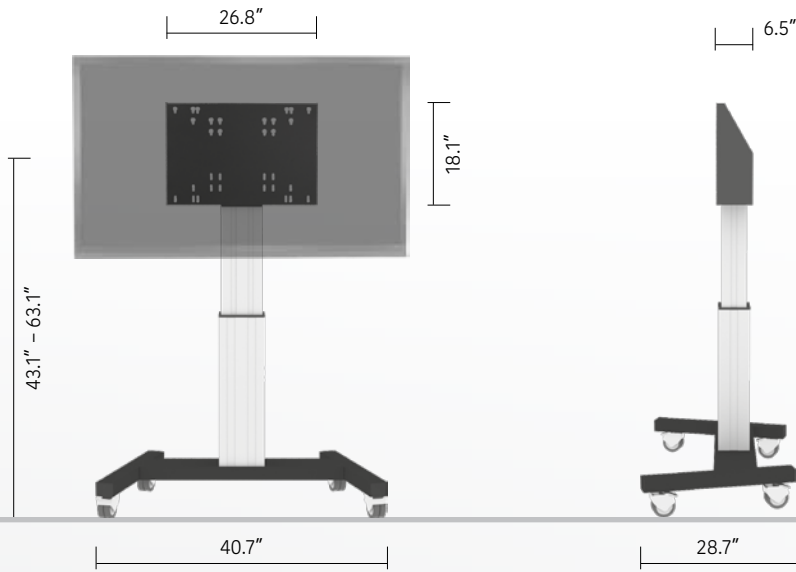

Product Code	SCETAVBOX
Display range	42" – 70"
VESA pattern	200 x 200 – 600 x 400
Load capacity	275 lbs
Shipping weight	101 lbs
Warranty	5 year



Wired remote control included

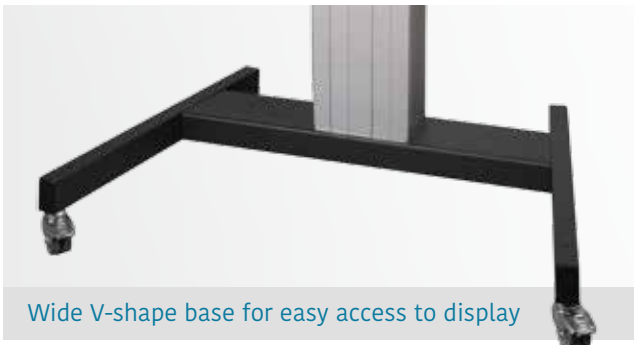

Wide V-shape base for easy access to display



Display mount with integrated VESA pattern and lots of storage space for hardware

Available accessories

More information on page 42 – 45



- Front shelf (pictured)
- Side shelf
- 3" casters

MOTORIZED MOBILE STAND FOR FLAT PANEL UP TO 84"



3-tier center column
ensuring perfect working height
for small children and teacher.

Renowned for its stability and versatility, the SCETA mobile stand has been ConenMounts' world wide best-selling mobile stand for many years.

The stand is designed to withstand intensive daily use and to safely support displays up to 84" or 300 lbs.

The SCETA comes in two models, offering 20" or 28" height adjustment. For user convenience and to enhance the teaching experience, the stand allows for several accessories to be mounted, including PC shelves, handles and whiteboard side wings.

For more info on this products scan the QR code



SCETA



SCETA3535

Key features

- Heavy duty mobile cart for 42" – 84" displays
- 'Pull & release' brackets for easy display mounting
- Integrated cable management
- Available with standard 20" travel or extended 28" travel for K-12
- Allows adding of handles and/ or whiteboard wings

Technical drawings

SCETA – 2-tier center column

SCETA3535 – 3-tier center column

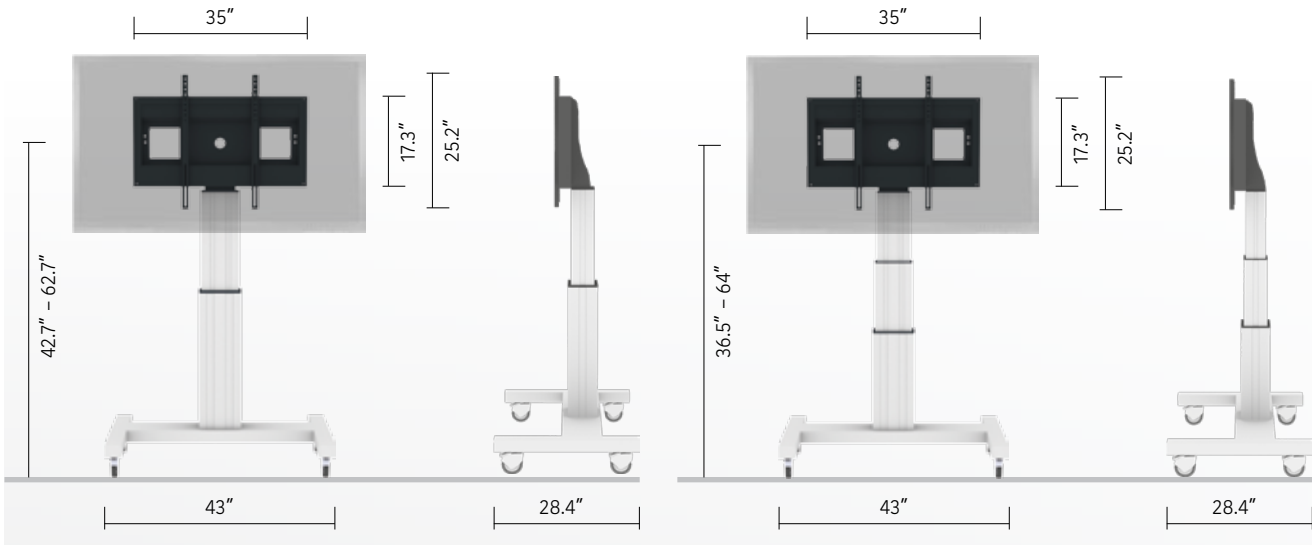

Product Code	SCETA	SCETA3535
Display range	42" – 84"	42" – 84"
VESA pattern	200 x 200 – 800 x 600	200 x 200 – 800 x 600
Load capacity	330 lbs	330 lbs
Shipping weight	128 lbs	136 lbs
Warranty	5 year	5 year



Pull & release locking brackets for easier mounting of display



Whiteboard wings optionally available

Available accessories

More information on page 42 – 45

- Front/ side shelf
- Side wings
- 3" casters (pictured)
- Handles
- VC camera shelf
- Rotating laptop shelf

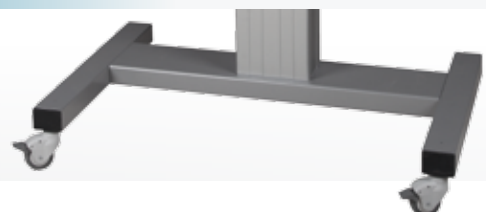

JOLLI EDUCATIONAL FLAT PANEL CART



The 'JOLLI Flat Panel Cart' is the next generation of flat panel carts for education. The cart allows for the display to be smoothly raised and lowered and to be moved from classroom to classroom, connecting teachers and students with the latest technologies. Designed for rugged environments, the cart features a sturdy metal base with 3" heavy-duty casters. The V-shape base ensures easy access, including those in wheelchair.

Large ergonomic handles on each side of the display aid mobility and help protect the display in transport.

Safely concealed in the center column is the UL certified actuator which offers 20" of smooth height adjustment. With a push of a button the display can be adjusted so that teacher and children can interact with the display.

For more info on this product scan the QR code



Key features

- Sturdy motorized mobile cart for K-6
- Compatible with 42" – 84" displays
- Cart comes standard with handles, rotating laptop shelf and 2 plastic bins
- Standard in stylish blue and aluminum
- 20" of safe and smooth vertical travel

Technical drawings

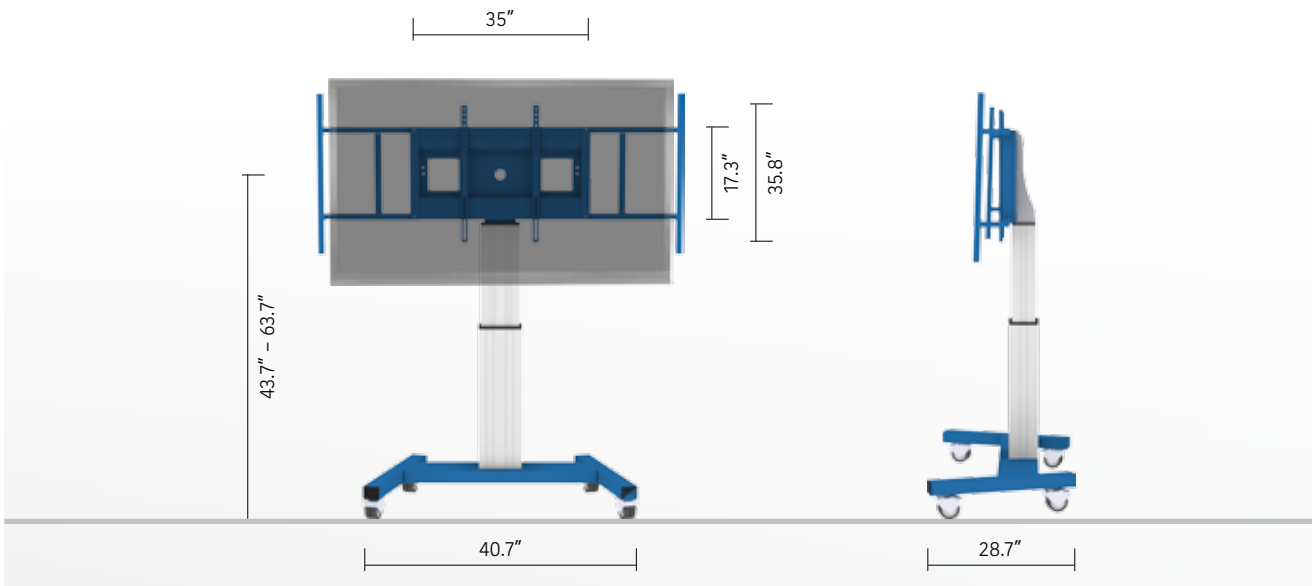

Product Code	JOLLI
Display range	42" - 84"
VESA pattern	200 x 200 - 800 x 600
Load capacity	330 lbs
Shipping weight	150 lbs
Warranty	5 year



2 large open storage bins



Ergonomic handles increase mobility & help protect the display in transport

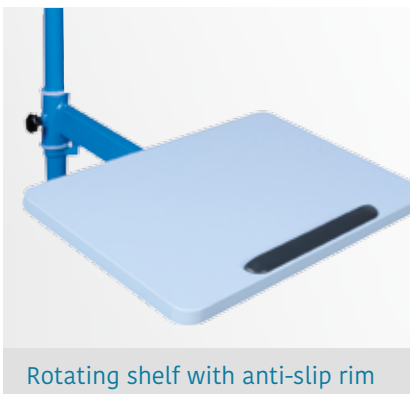

Rotating shelf with anti-slip rim

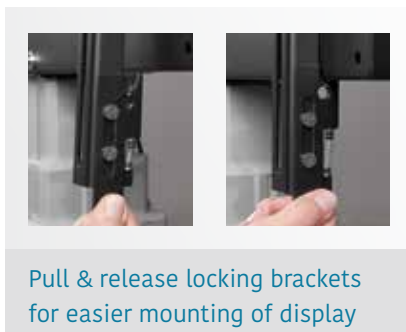

Pull & release locking brackets for easier mounting of display

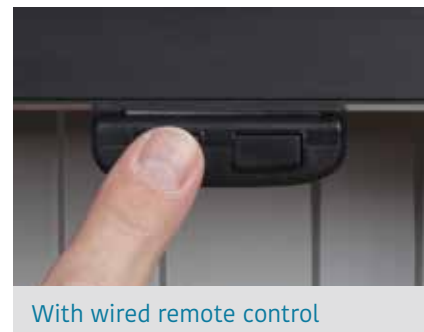

With wired remote control

HEIGHT & TILT ADJUSTABLE MOBILE FLAT PANEL STAND



TILTABLE
90°

Height and
tilt adjustable

20"

ConenMounts 'SCETTA' mobile height and tilt adjustable cart is among ConenMounts best-selling carts.

Designed for Higher Ed, hospitality or corporate use, this small group collaboration solution offers 20" of smooth height adjustment and 0 – 90° motorized tilt adjustment, allowing for virtually any 46" – 75" panel to be used in table and display mode or any required mid-point position.

Fitted with braking castors the SCETTA is easily moved from room to room making it ideal for flexible work spaces and special needs environments.

For more info on this product scan the QR code



Key features

- Mobile cart with motorized height and tilt adjustment
- Compatible with 46" – 75" displays and max. VESA 800 x 600
- 20" height adjustment
- Tilt feature to position display in tilted or table top position (0 – 90°)

Technical drawings

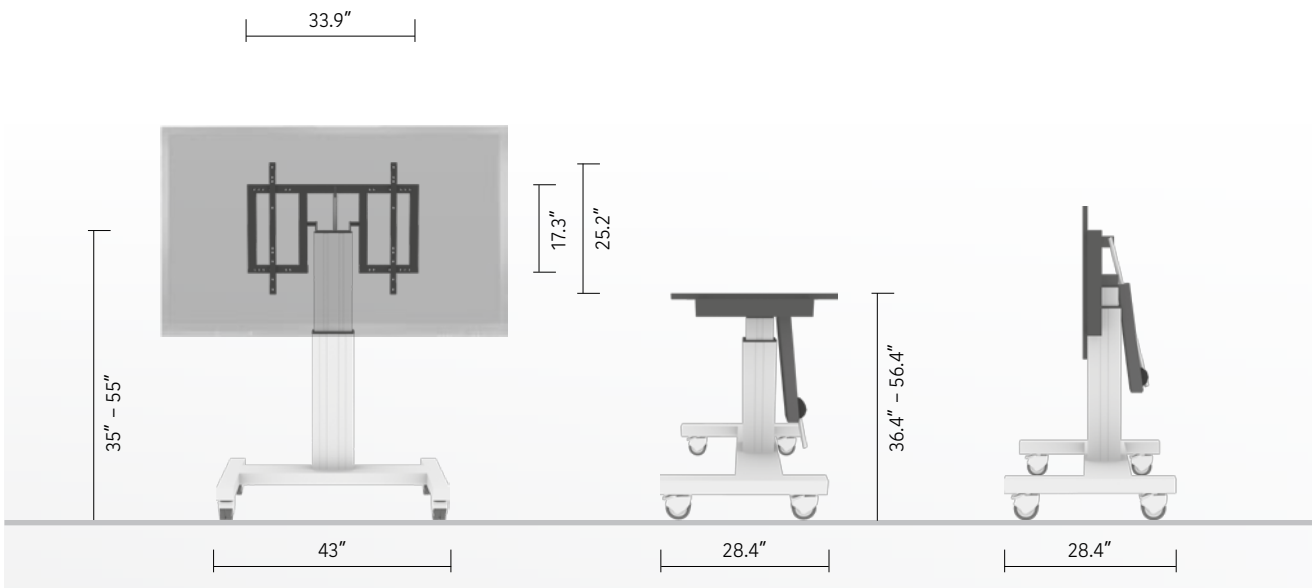

Product Code	SCETTA
Display range	46" - 75"
VESA pattern	280 x 200 - 800 x 600
Load capacity	330 lbs
Shipping weight	154 lbs
Warranty	5 year

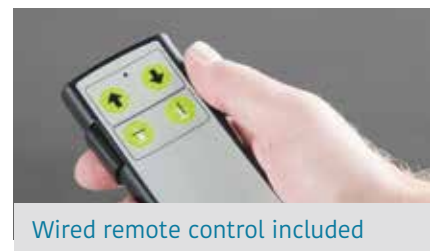
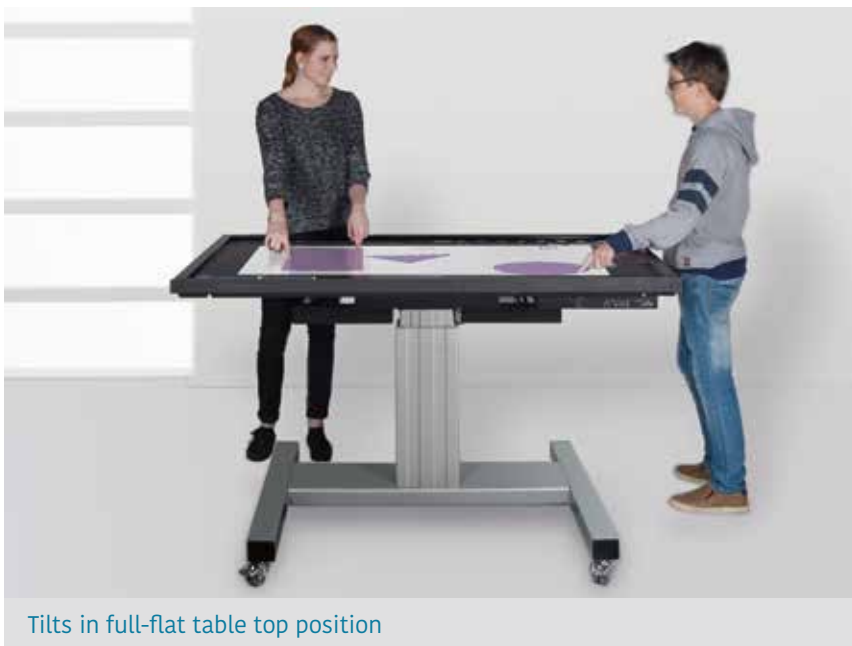

Available accessories

More information on page 42 - 45



- Front shelf (pictured)
- Side shelf
- 3" casters

HEIGHT & TILT ADJUSTABLE FLAT PANEL CART FOR K-12



Small group learning activities require for flexible interactive solutions. The ConenMounts height and tilt adjustable carts give schools the freedom to create a collaborative area wherever needed. The mobile carts are height adjustable to accommodate children of various heights or those in wheelchairs.

The 'SCETTAL' is designed for use in Kindergarten and features a short column with 11" of height adjustment, the

'SCETTA3535' features the new 3-tier column which offers an extended 28" of vertical travel, making it the perfect solution for K-12 or special needs applications.

It provides minimum clearance for small children or those in wheelchair to access the display and maximum clearance for the teacher to present. Both models feature motorized tilt, allowing for the panel to be adjusted from 90° to fully horizontal.

For more info on this products scan the QR code



SCETTAL



SCETTA3535

Key features

- Height and tilt adustable carts designed for K-12
- Compatible with 46" – 75" displays and max. VESA 800 x 600
- Low model with 11" vertical travel or model with extended 28" travel
- Tilt feature to position display in tilted or table top position (0 – 90°)

Technical drawings

SCETTAL

SCETTA3535

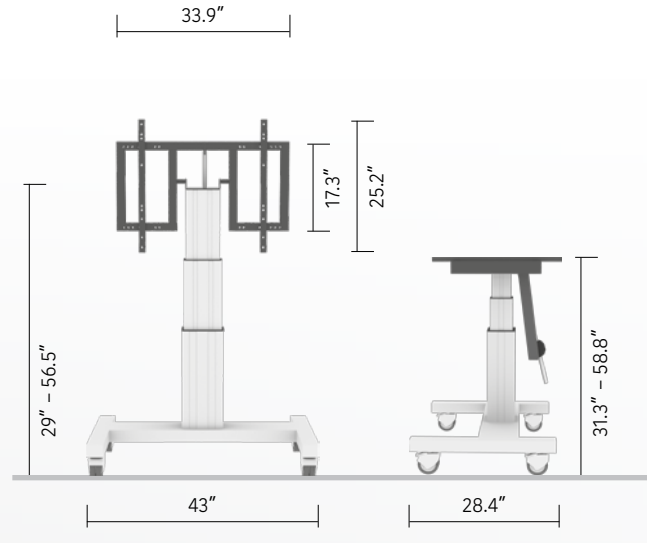
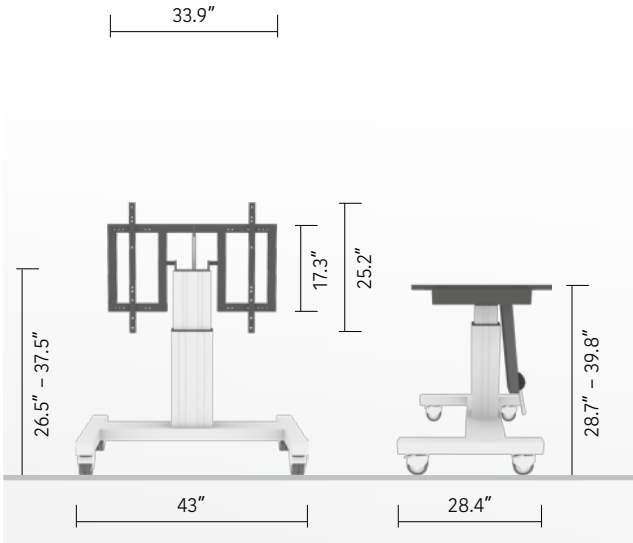

Product Code	SCETTAL	SCETTA3535
Display range	46" – 75"	46" – 75"
VESA pattern	280 x 200 – 800 x 600	280 x 200 – 800 x 600
Load capacity	330 lbs	330 lbs
Shipping weight	149 lbs	163 lbs
Warranty	5 year	5 year



Wired remote control included



Available accessories

More information on page 42 – 45



- Front shelf
- Side shelf (pictured)
- 3" casters

MOTORIZED MOUNT AND STAND WITH XL DISPLAY MOUNT

Designed for use with
SMART Board™ 4075 and
Microsoft® Hub 84"



20"

Designed specifically for use with the SMART Board® 4075 and the Microsoft Surface Hub 84" interactive flat panel, this motorized mobile cart features a wide display mount with VESA 1000 x 600 and 1200 x 600 mounting pattern.

The SCETAW12 wall mount system and SCETA12 mobile mount come standard with the 2-tier column that offers 20" of height adjustment.

Large handles on each side of the display are optionally available for the mobile stand to increase mobility and to help protect the display in transport.

For more info on this products scan the QR code



SCETA12



SCETAW12

Key features

- Motorized solution with extra wide display mount
- Display mount with VESA 1000 x 600 and 1200 x 600
- 'Pull & release' brackets for easy display mounting
- 20" of vertical travel

Technical drawings

SCETA12

SCETAW12

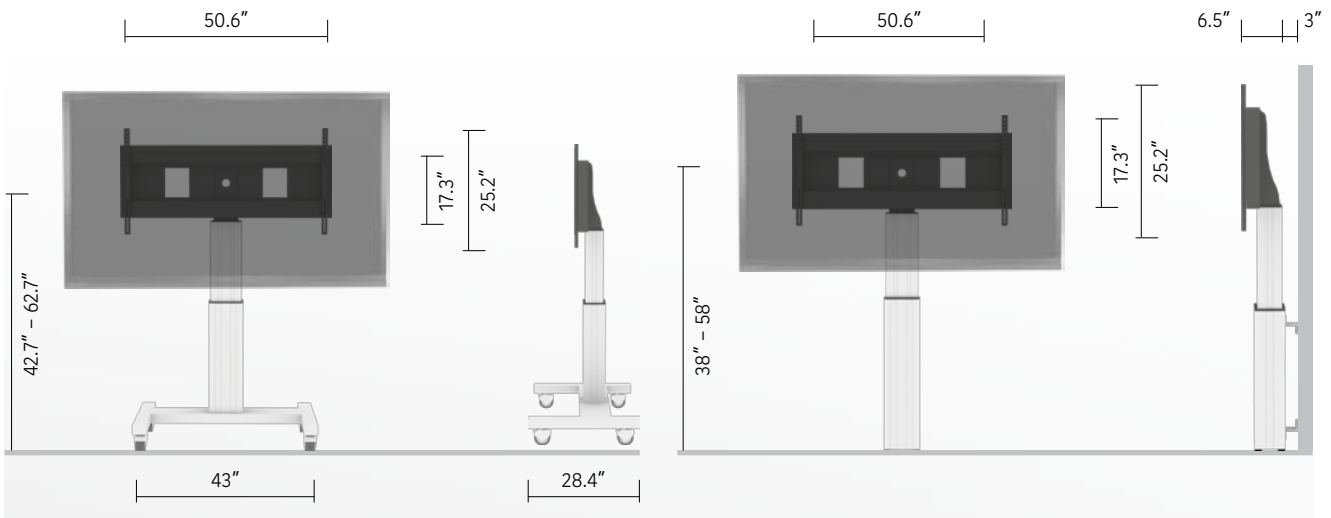

Product Code	SCETA12	SCETAW12
Display range	42" - 84"	46" - 75"
VESA pattern	1.000 x 600 - 1.200 x 600	1.000 x 600 - 1.200 x 600
Load capacity	330 lbs	330 lbs
Shipping weight	139 lbs	85 lbs
Warranty	5 year	5 year

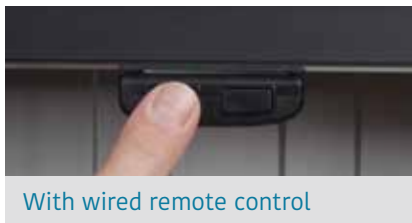

Available accessories

More information on page 42 - 45

- Front shelf
- Stud wall mounting bracket
- Side shelf
- Handles on each side of display
- Floor plate



- VC camera shelf
- Rotating laptop shelf (pictured)

FIXED HEIGHT FLAT PANEL MOUNTS AND STANDS



For applications that do not necessarily require height adjustment or where price is key, ConenMounts offers a series of fixed height solutions.

The systems feature a sturdy aluminum center column that comes in different fixed heights. Mounted atop the center column is the box style display mount which allows

for hardware and cables to be stowed away neatly behind the display.

The mobile solution features the contemporary black, V-shaped, base with sturdy 2" casters.

For more info on this products scan the QR code



SCETANHVV B



SCETANHVWB

Key features

- Entry model Flat Panel cart and stand
- Fixed height
- Designed for displays up to 70" and max. VESA 600 x 400
- Sheet metal box mount with integrated VESA pattern
- Box allows for hardware to be neatly stowed behind the display

Technical drawings

SCETANHVVB

SCETANHVWB

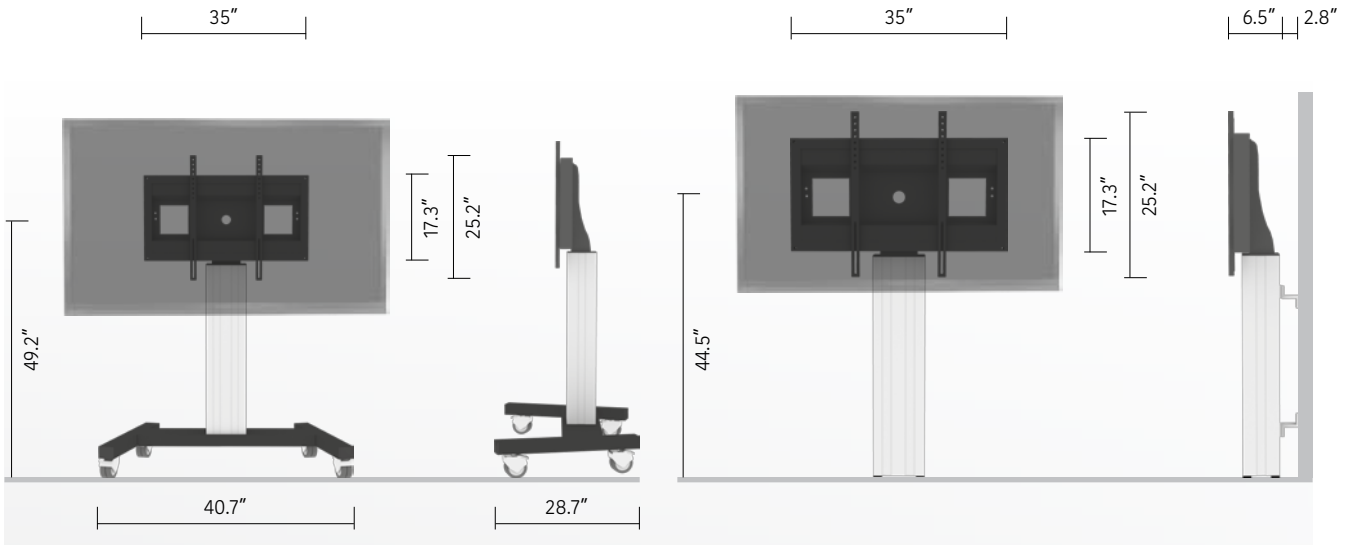

Product Code	SCETANHVVB	SCETANHVWB
Display range	42" - 84"	42" - 84"
VESA pattern	200 x 200 - 600 x 400	200 x 200 - 600 x 400
Load capacity	330 lbs	330 lbs
Shipping weight	92 lbs	56 lbs
Warranty	5 year	5 year

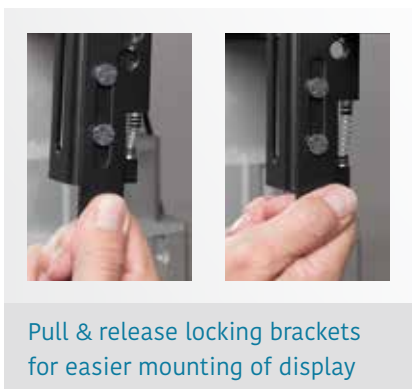
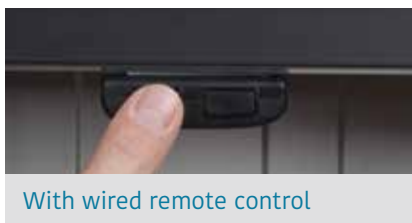

Available accessories

More information on page 42 - 45

- Front shelf
- Side shelf

- Stud wall mounting bracket (pictured)
- Floor plate

OVER THE BOARD MOUNT



ConenMounts 'Over the Board Mount' allows you to mount the flat panel display over the existing dry erase or chalk board. The system features two sturdy 2" posts that attach above and below the existing board and offers a 4" - 5.5" clearance to clear any chalk tray.

A steel display mount with two 'pull and release' locking brackets ensures quick and easy mounting of the display. The integrated leveling screws allow for the display to be leveled after the display is attached.

For more info on this product scan the QR code



Key features

- Heavy duty over the board mount for IFPD
- Compatible with 42" - 84" displays with max. VESA 800 x 600
- Extended version available for displays with VESA 1.000 x 600
- 'Pull & release' brackets for easy display mounting

Technical drawings

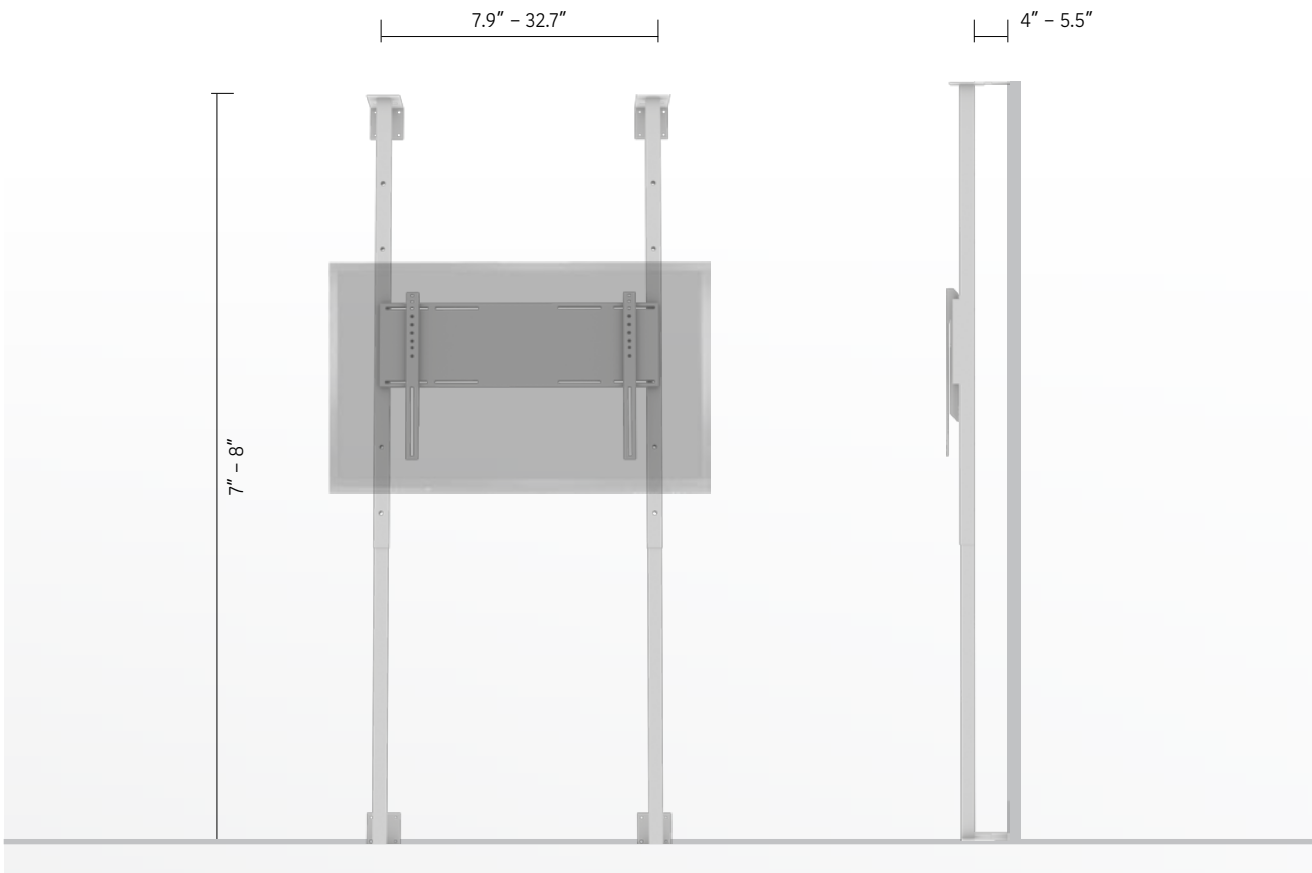

Product Code	OTB
Display range	42" – 84"
VESA pattern	280 x 200 – 800 x 600
Load capacity	330 lbs
Shipping weight	150 lbs
Warranty	5 year

SMART KAPP 42 STAND

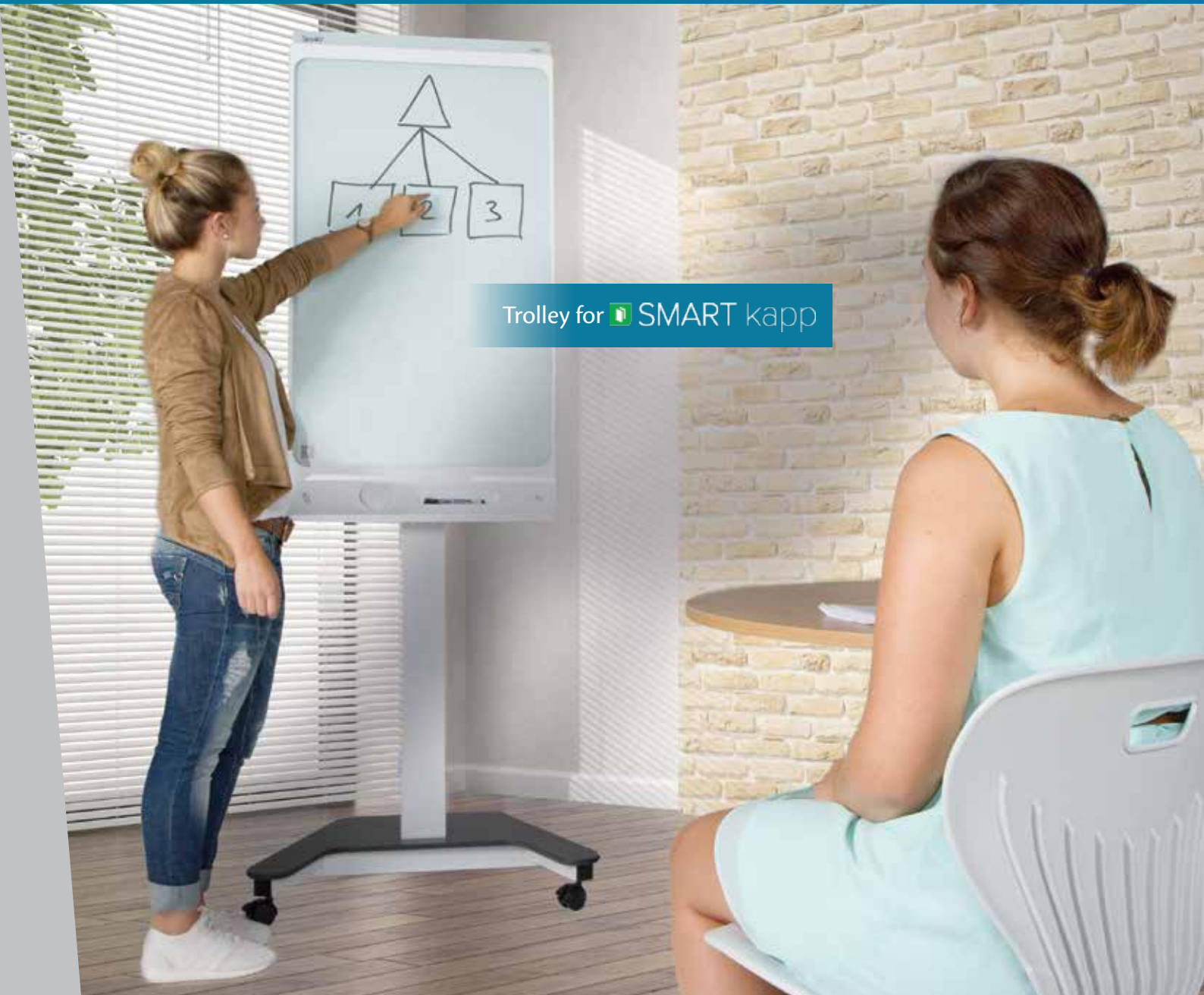

Trolley for  SMART kapp

The ConenMounts kapp 42 stand provides a stable and stylish mobile solution for SMART kapp 42 capture board.

The V-shaped base ensures optimum stability and allows easy access to the board. Its white finish complements the design of the SMART kapp 42.

The stand key features two mount positions for optimum ease of use and fits through any standard door opening, offering optimum flexibility in education, hospitality or business.

For more info on this product scan the QR code



Key features

- Mobile cart designed for use with SMART kapp 42
- Stylish design and white color compliment the SMART kapp 42
- Two mounting positions for maximum ease of use
- Fits through any door opening
- Ships flat packed and is courier shippable



Standard

SMART kapp 42 trolley comes standard with powder coated, steel mobile base with 4 casters (2 locking) for easy transportation.

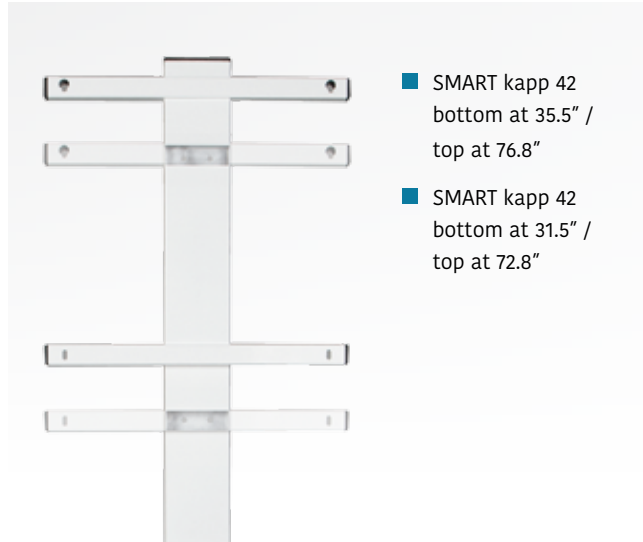

- SMART kapp 42 bottom at 35.5" / top at 76.8"
- SMART kapp 42 bottom at 31.5" / top at 72.8"

Two mounting positions for maximum ease of use

Technical drawings

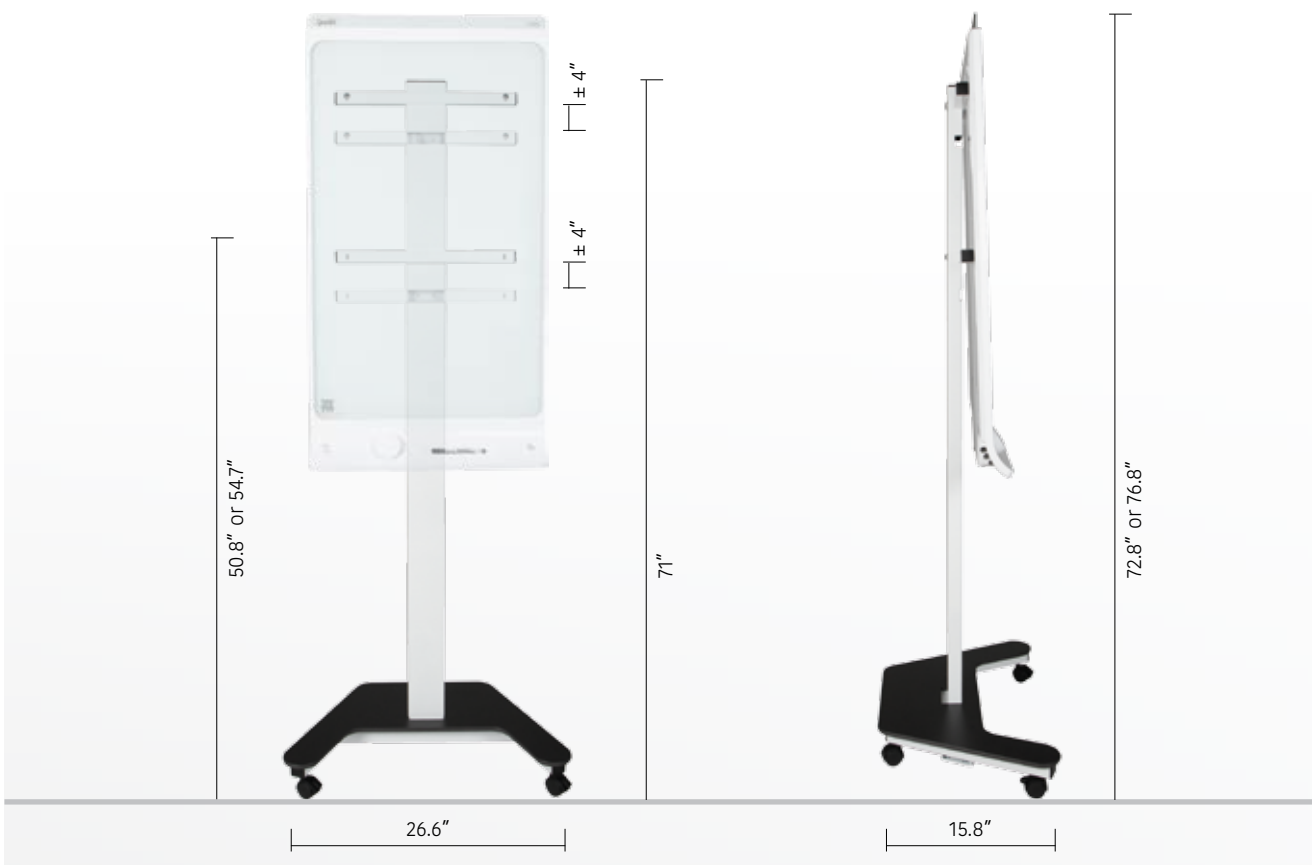

Available accessories

Cover for mobile base

Black covering plate made of Compact/ Solid Grade Laminate



Product Code Skap42-cov

Product Code	Skap42-tro
Shipping weight	33 lbs
Warranty	3 year

MOTORIZED WALL MOUNT FOR IWB

Compatible with virtually any interactive whiteboard and projector



ConenMounts motorized IWB wall mount makes virtually any interactive whiteboard height adjustable. The solution is sold as a package with an ultra short throw projector arm and a mounting plate for any UST projector.

Add 20" of smooth motorized height adjustment to your IWB and allow pupils and teachers access to the full whiteboard.

Because the projection system is supported by the center column, the weight of the system is resting on the floor. Whether mounted to a solid wall or stud wall, the ConenMounts solution safely supports your whiteboard.

For more info on this product scan the QR code



Key features

- Compatible with all major brands of IWB
- Complete solution with integrated projector arm
- Fits virtually any ultra short throw projector
- 20" of smooth motorized height adjustment

Technical drawings

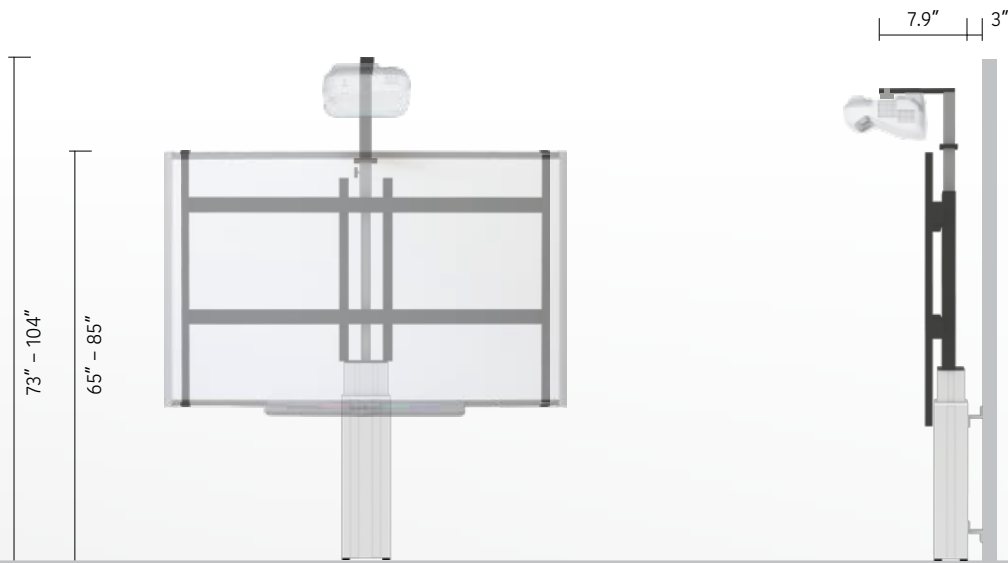

Product Code	SCETAW-IWB
Shipping weight	approx. 140 lbs
Warranty	5 year



Levelling feet and 2 wall mounting brackets for optimum stability

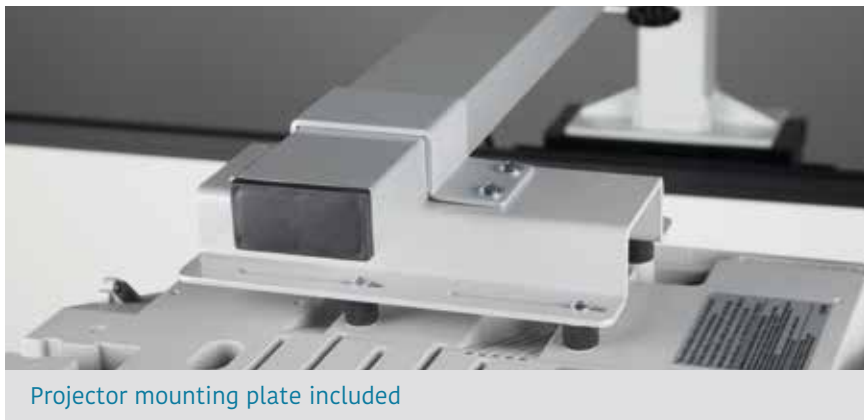

Projector mounting plate included



Brackets fit the shape of the board (pictured Promethean board)

Available accessories

More information on page 42 – 45

- Front shelf
- Side shelf



- Floor plate (pictured)
- Stud wall mounting bracket

MOTORIZED MOBILE STAND FOR IWB

Compatible with virtually any interactive board and projector

20"

Engage your audience anywhere with ConenMounts motorized mobile stand. The stand allows a complete mobile interactive whiteboard system to be transported around a building with the minimum set-up time.

The rotating projector arm allows for the unit to be moved through any standard door opening.

At the touch of a button the screen can be raised or lowered 20" creating a comprising learning and working environment for all sizes, ages and abilities including wheelchair users.

The solution is compatible with virtually any 78" and 87" whiteboard and virtually any ultra short throw projector.

For more info on this product scan the QR code



Key features

- Compatible with all major brands of IWB and projectors
- Complete solution with integrated projector arm
- Fits virtually any ultra short throw projector
- 20" of smooth motorized height adjustment
- Fits through standard door opening

Technical drawings

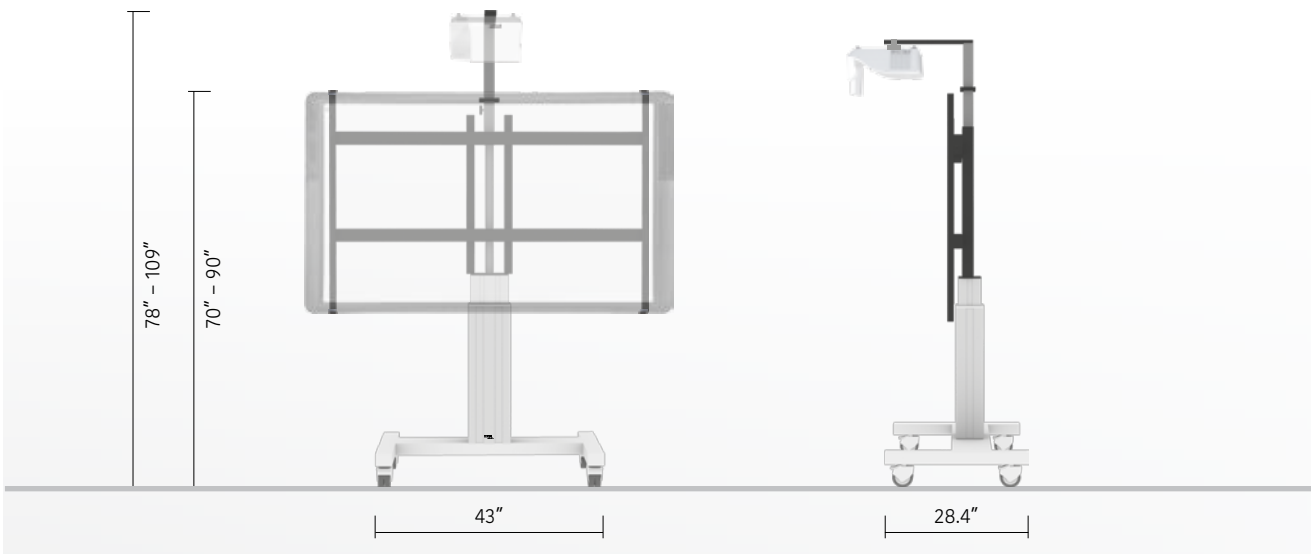

Product Code	SCETA-IWB
Shipping weight	approx. 195 lbs
Warranty	5 year



With wired remote control



Mounting plate included



Rotating projector arm ensures the system fits through a door opening

Available accessories

More information on page **42 – 45**



- Front shelf (pictured left)
- Side shelf (pictured right)



WORKITDESK INTERACTIVE TABLE

Designed for use with Epson
BrightLink® Pro 1430Wi



TILTABLE
90°



20"

The ConenMounts 'workITdesk' is a mobile height and tilt adjustable desk surface made interactive via attached interactive projector.

The 'workITdesk' is designed specifically for use with the Epson Brightlink Pro 1430wi.

It key features a white, non-dry erase top with predrilled mounting positions for control pad and finger touch unit

and allows for a 74" diagonal projected image. Surface and projector can be moved smoothly from table mode to wall display or in any required mid-point position.

Its unique key features and the flexibility in both use and deployment make the 'workITdesk' a compelling small group collaboration solution for businesses.

For more info on this product scan the QR code



Key features

- Designed for use with Epson BrightLink® Pro 1430Wi
- Projector arm and mounting plate included
- 50" x 67" white, non-dry erase table top
- Motorized height & tilt adjustment
- Fits through a standard door

Technical drawings

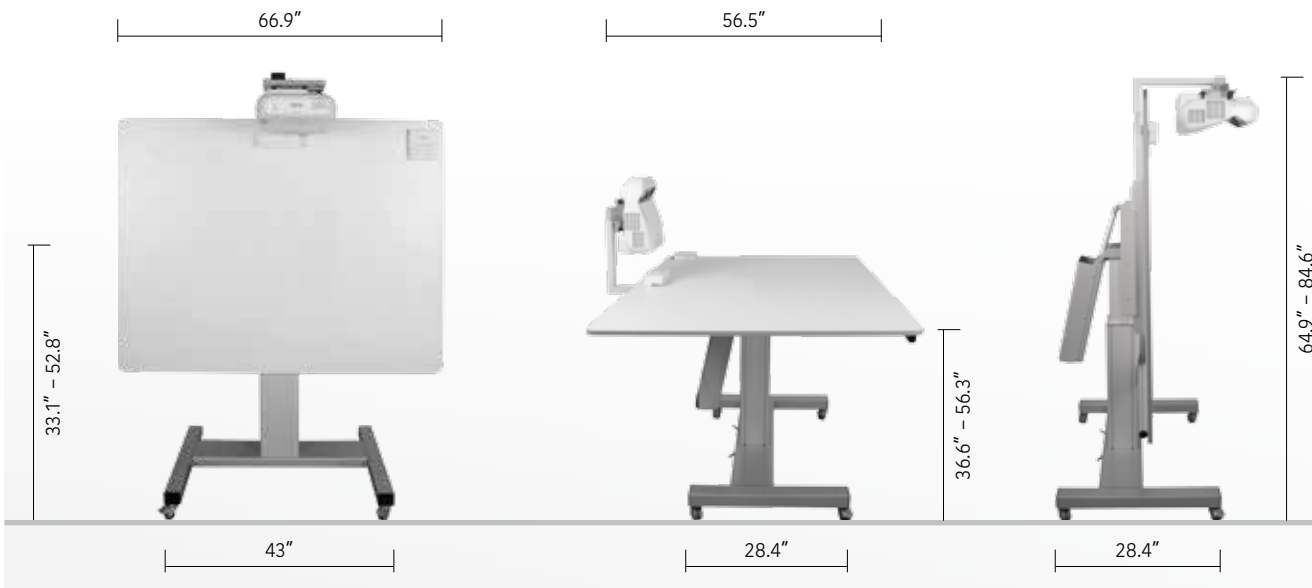

Product Code	WID
Projection area	63" x 40" (74" diag./ 16:10)
Surface	White, Non dry erase
Compatible with	Epson Brightlink Pro 1430wi
Shipping weight	249 lbs
Warranty	3 year



Cuts outs in table top to run cables to finger touch unit and control pad



Ergonomic working in table top or display position

Available accessories

More information on page 42 – 45



■ Side shelf

WORKITDESK DELUXE INTERACTIVE & DRY ERASE TABLE



The 'workITdesk DeLuxe' is the dry-erase version of the 'workITdesk' mobile height and tilt adjustable table.

It key features a black table top with a 74" diagonal dry erase and magnetic projection surface applied.

The unit is compatible with virtually any ultra short throw interactive projector. The finger touch unit can be either applied onto the projection surface or attached over the surface directly into the board.

The unit offers a smooth and safe 20" vertical travel and 0 – 90° tilt adjustment of surface and projector. Retracted the 'workITdesk' fits through a standard doorway with the projector still connected.

The 'workITdesk deluxe' is the ideal solution for schools that are looking for mobile, customized interactivity.

For more info on this product scan the QR code



Key features

- Compatible with virtually any Ultra Short Throw projector
- Projector arm and mounting plate included
- Black top with 74" dry erase and magnetic projection surface applied
- Fits through a standard door
- Motorized height and tilt adjustment

Technical drawings

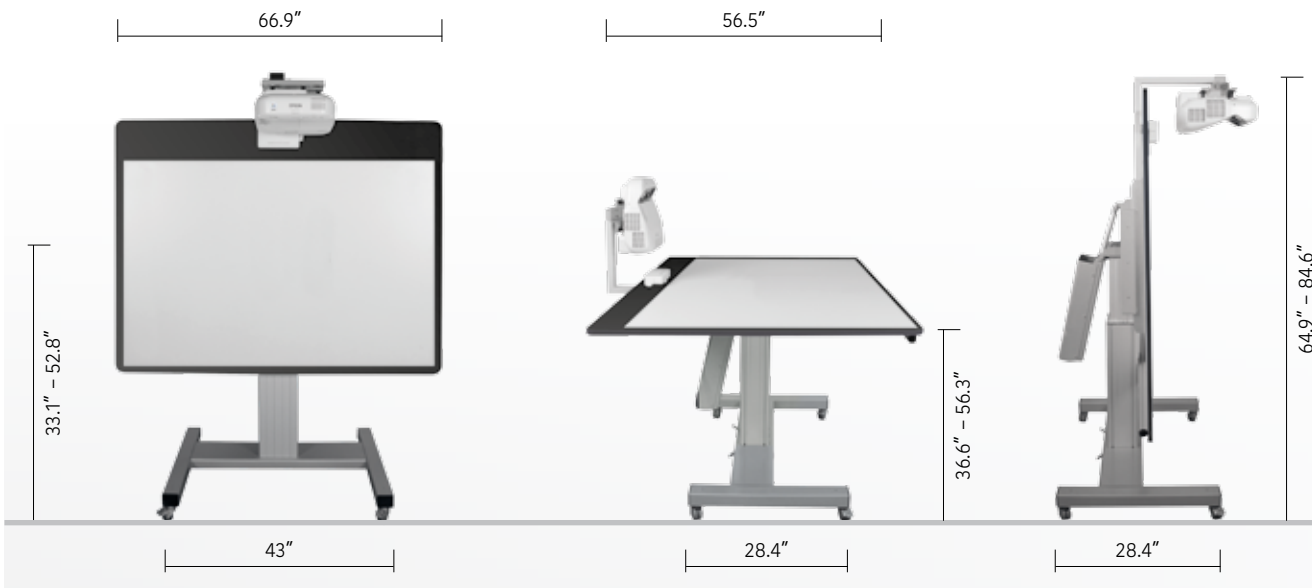

Product Code	WID-DL74
Projection area	63" x 40" (74" diag./ 16:10)
Surface	Black top with 74" deluxe projection surface
Shipping weight	249 lbs
Warranty	3 year



Opening to run cable to finger touch unit



Wired remote control included



Available accessories

More information on page 42 - 45



■ Side shelf

MOTORIZED MOBILE BOARD SYSTEM

Compatible with any
interactive UST projector



20"

The mobile version of ConenMounts' projection board system for interactive projectors, featuring the ConenMounts 'DeLuxe' 95" projection board, an integrated projector arm support and ConenMounts motorized mobile stand.

The mobile base and the rotating projector arm allow easy transportation of the complete interactive system from room to room.

With its large 95" projection board and the 20" of height adjustment the system is the ideal mobile solution for presentations, teaching or group displays.

For more info on this
product scan the QR code



Key features

- Complete mobile solution for interactive projector
- Features dry erase and magnetic 'DeLuxe' projection surface
- Fits through standard door opening
- 20" of motorized height adjustment

Technical drawings

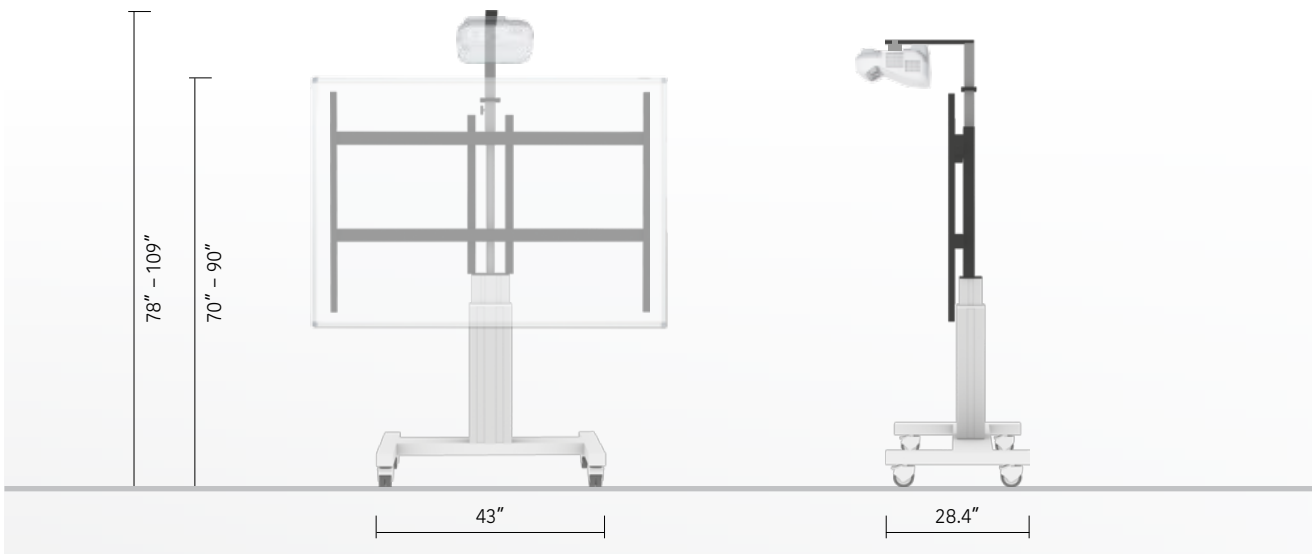

Product Code	SCETA-IP
Shipping weight	approx. 350 lbs
Warranty	3 year

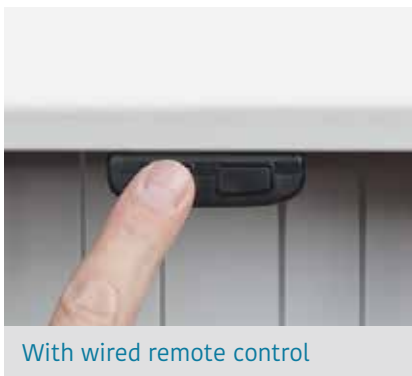

Available accessories

More information on page 42 – 45

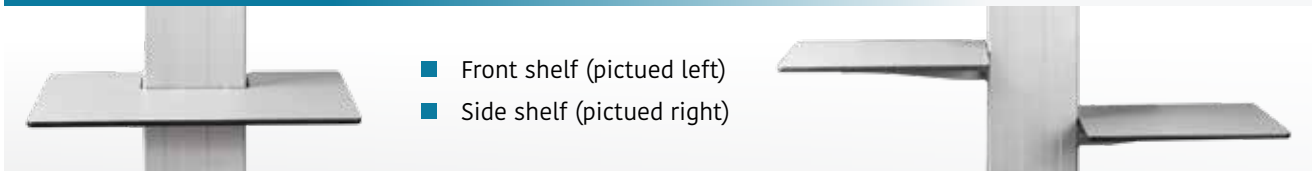

MOTORIZED BOARD SYSTEM FOR INTERACTIVE PROJECTORS

Complete with DeLuxe
projection board

20"



Capture your audience attention with ConenMounts board system for use with interactive projector.

The unit consists of a motorized wall mount, the Conen Mounts 'DeLuxe 95" projection board' and a projector arm with mounting plate for virtually any (interactive) ultra short throw projector.

The 'DeLuxe 95" projection board' is designed for use with interactive projectors; the magnetic and dry erase board features a special low glare projection grade surface.

With a simple touch of a button the UL-approved electric system offers 20" of smooth motorized height adjustment, allowing access to anyone.

For more info on this product scan the QR code



Key features

- Complete wall mount solution for interactive projector
- Features dry erase and magnetic 'DeLuxe' projection surface
- Compatible with virtually any ultra short throw projector
- 20" of smooth motorized height adjustment

Technical drawings

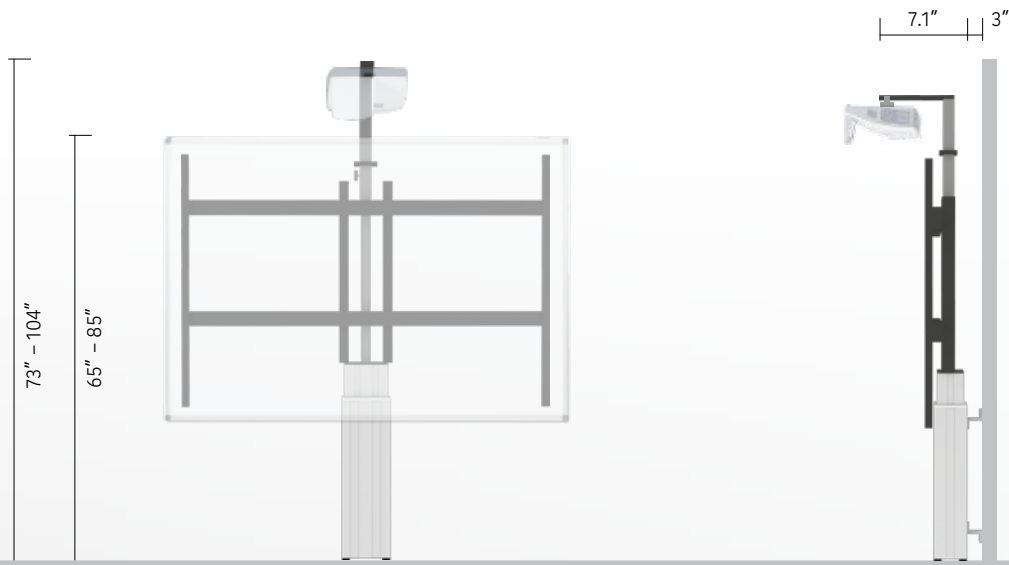

Product Code	SCETAW-IP
Shipping weight	approx. 295 lbs
Warranty	3 year



Thin bezel works with any interactive projector. More informations on page 40.



Magnetic surface



Stud wall mounting bracket optionally available

Available accessories

More information on page 42 – 45

- Front shelf
- Side shelf



- Floor plate (pictured)
- Stud wall mounting bracket

DELUXE PROJECTION SCREEN AND MARKERBOARD

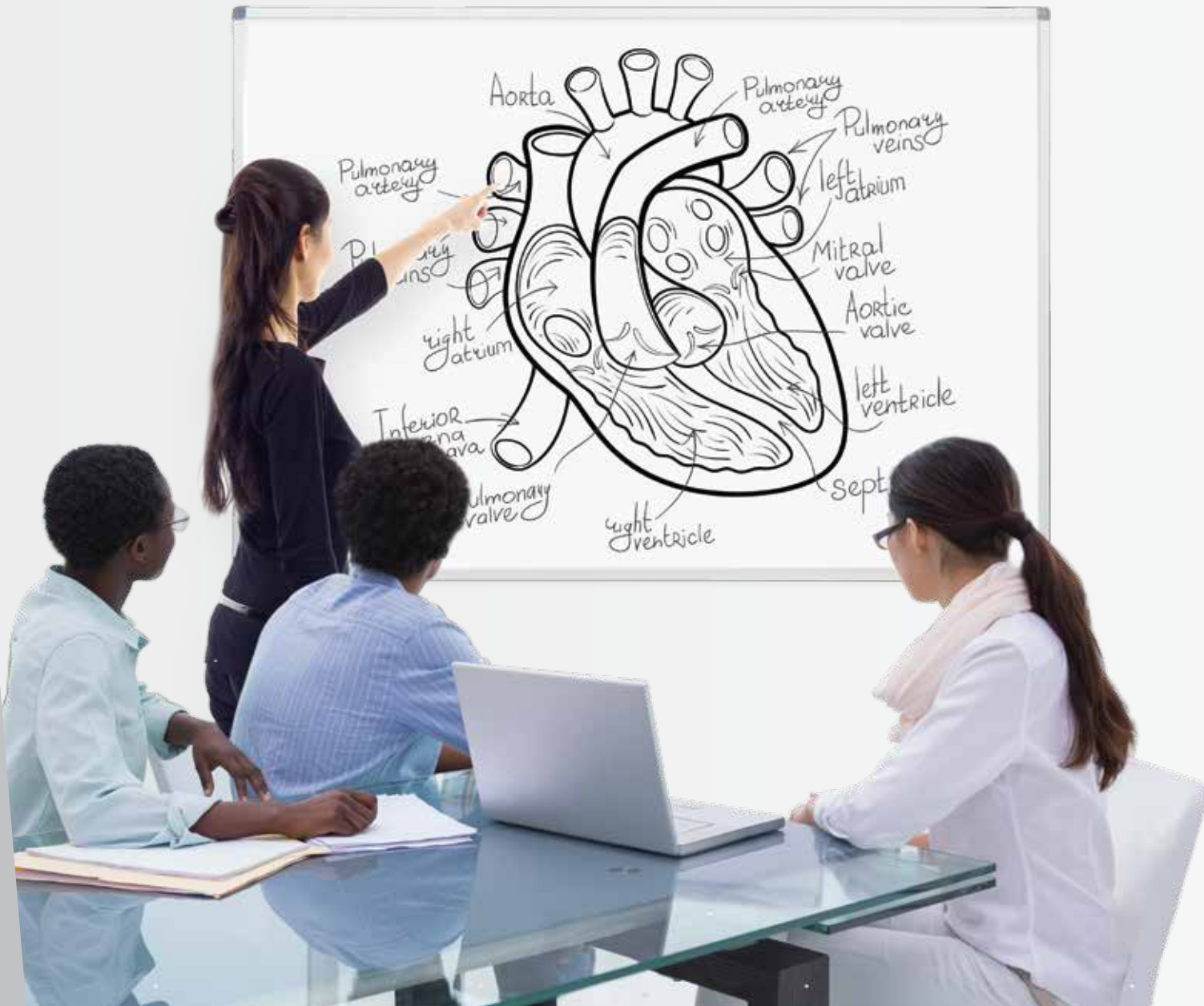

The ConenMounts 'DeLuxe' projection grade board screen is designed specifically for use with (interactive) projectors. The boards feature a low glare, hotspot-free surface, offering a wide viewing angle.

The surface is framed in a thin, clear anodized aluminum frame with mere 0.075" bezel thickness at the screen surface, guaranteeing compatibility with even the most

demanding interactive projector. The surface is magnetic and erasable, allowing for the board to be used both as a projection screen and as a whiteboard with dry erase markers and magnets.

The highly stable construction of honeycomb core and steel surface on both sides ensures perfect screen flatness.

For more info on this products scan the QR code



WB-DL95



WB-DL110

Key features

- Hotspot-free, projection-quality surface
- Matte white, low glare surface offering wide viewing area
- Magnetic and dry erase
- Aesthetic, anodized aluminum frame
- Thin 0.075" bezel, designed for use with interactive UST projectors
- Metal wall brackets for easy wall mounting

Technical drawings

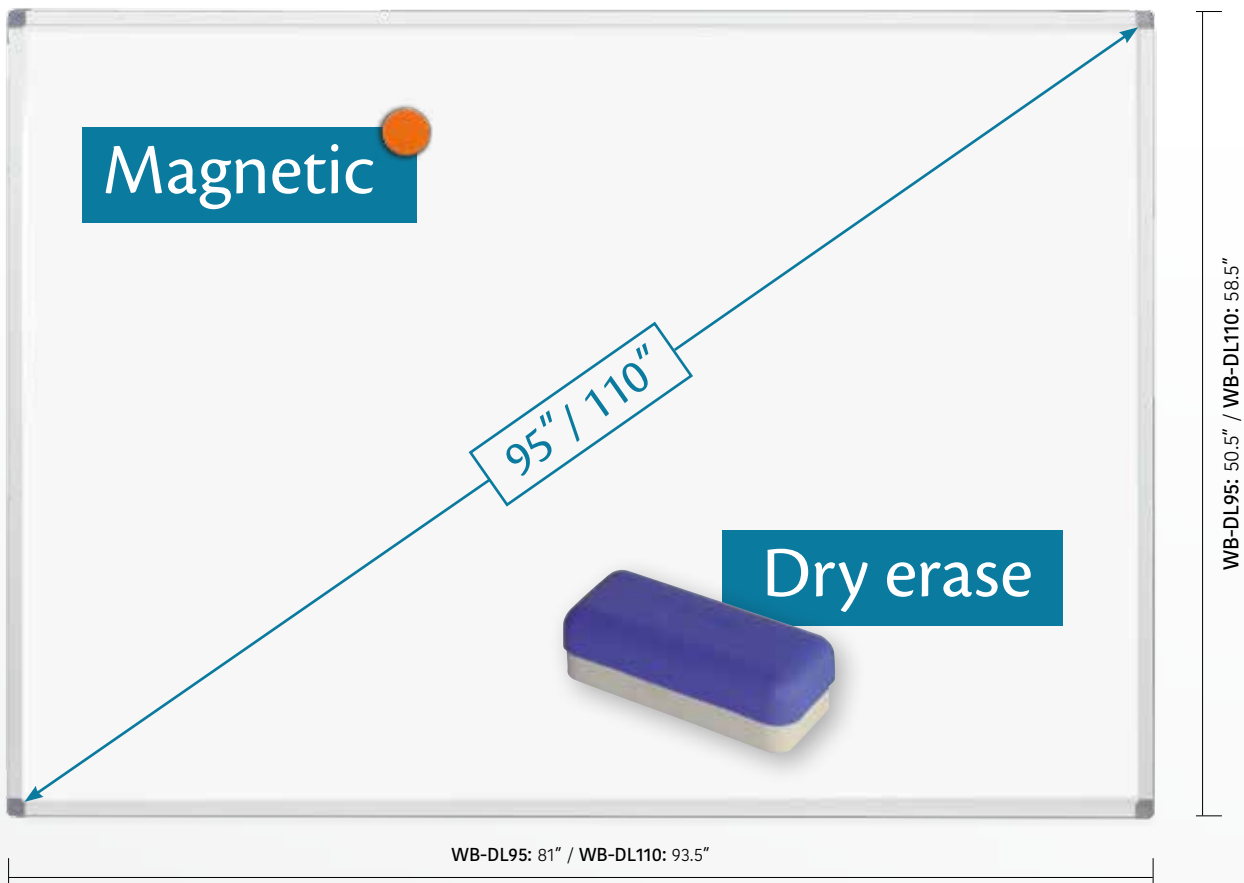

Product Code	WB-DL95	WB-DL110
Board	81" - 50.5"	93.5" - 58.5"
Shipping weight	70 lbs	90 lbs
Warranty	2 years	2 years



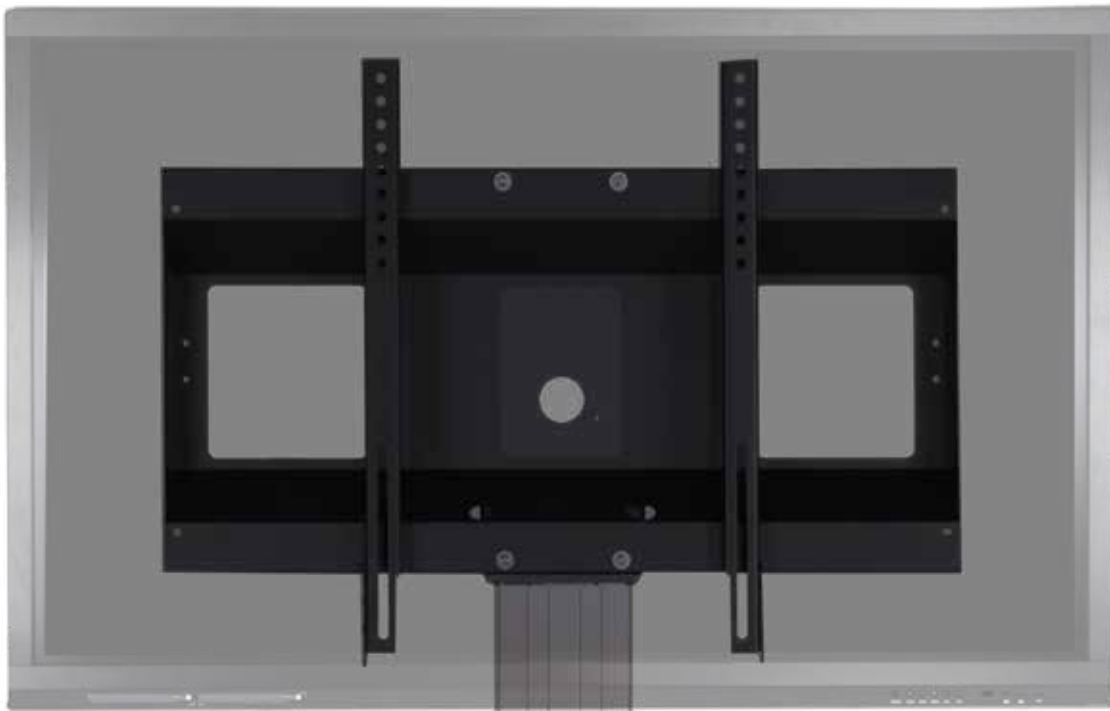

H-shape mobile base

- Dimensions, W/D: 43 x 28.4"
- Powdercoated in aluminum grey

1

V-shape mobile base

- Dimensions, W/D: 40.7 x 28.7"
- Powdercoated in black

2

Floor plate

- Solid steel plate, 0.3" thick
- Powdercoated in aluminum grey
- For static floorstand applications

3

4 casters set

- 3" casters – especially recommended for use on uneven floors and frequent transports from room to room
- Fits all types of mobile bases



Product Code PSTSCETA

Product Code GR 10

Front shelf



4

Dimensions, W/D:
24.4 x 17.3"

Product Code FSH-VG

Side shelf (1 pce.) – for mounting to left or right side



5

Dimensions, W/D:
17.7 x 12.8"

Product Code LAP4-VG



2



3



Video Conference Camera Top Shelf



- Height adjustable
- Pre-drilled mounting holes and elastic straps to secure camera to shelf
- Shelf dimensions: 9.8" x 5.9"

Product Code | VCTSCETA

Set of whiteboard side wings

- Dry-erase and magnetic
- Wings attach to a metal frame that is secured to the display mount.



Available for a wide range of Flat Panel Displays.

For a complete and up-to-date list of the available models, please visit www.conenusa.com or scan the QR code below.



Product Code | SWBW-..

Lockable mini PC bracket

To securely mount your mini-PC to the motorized wall mount or mobile stand. Attaches on either left hand or right hand side. For a complete overview of the available models, visit our website.

Product Code | MINI



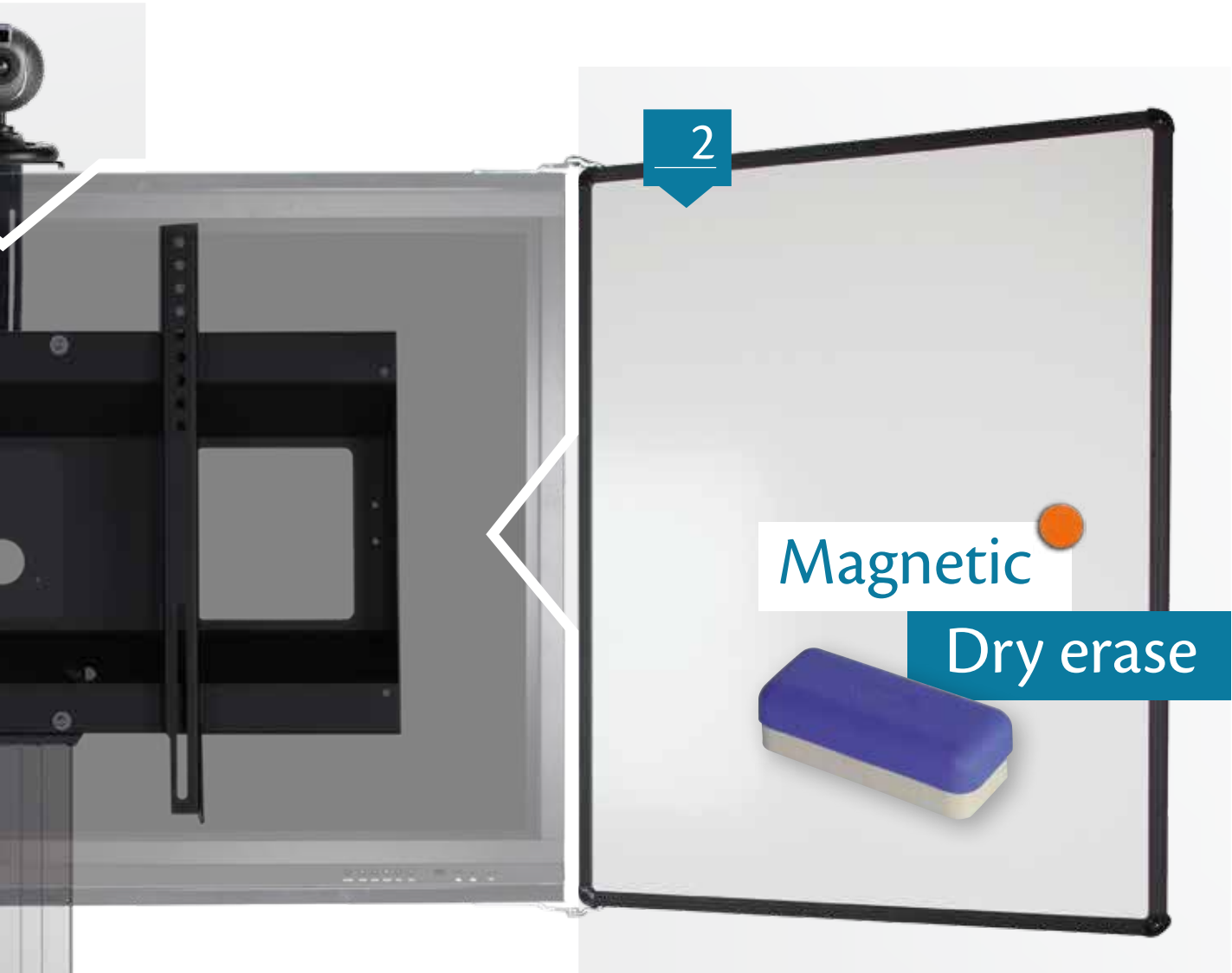

All wall mount systems come standard with two 2.75" wall mount brackets. Below listed brackets are optionally available.



U-shaped wall bracket

- Clearance: 4"
- Powdercoated in aluminum grey
- 9-hole mounting pattern for secure mounting to the wall

Product Code WMB-SCETS



2 wall mounting brackets

- Clearance: 4.3"
- Galvanized

Product Code CCZ11



Set of adjustable wall mounting brackets

- Clearance: 5.1" – 7.1"
- Galvanized

Product Code CCE70WZ

ConenMounts is a brand of Conen Products, a leading manufacturer of educational furniture and visual presentation equipment headquartered in Germany. Part of its extensive portfolio is a range of board solutions.

Built on its 40 years of experience, ConenMounts solutions are designed around the educator and installer. They offer ease of installation and ease of use, provide flexibility and complement the technology they support. All products are designed to withstand intensive daily use and to offer perfect ergonomics.

ConenMounts continues to be an industry leader, designing state-of-the-art mount solutions.

This catalogue shows only a small part of the full product line. Few more examples of products manufactured by Conen are shown below. Feel free to reach out to us if you would like to receive more information on these products or if you have any other questions or requests.



Motorized mobile stand for 100" displays

Designed for use with flat panel displays over 100" in diagonal or over 330 lbs. The 'SCETA12X2' motorized mobile stand features two aluminum columns with integrated actuators, offering a 20" vertical travel.



Flat panel mounts with A/V cabinets

ConenMounts offers a full line of AV furniture, including motorized flat panel carts with locking cabinets. All these products are customizable.



Digital signage mounts

ConenMounts collection of digital signage mounting solutions includes back-to-back screen mounts and mounts with rotating mount that accommodate flat panels in landscape or portrait orientation.

For more info, visit conenusa.com



Legal

Manufacturer of the furniture depicted in the catalog is the company Conen Produkte GmbH & Co. KG.

ConenMounts is a trading brand of Conen. All other product and brand names are trademarks and/or registered trademarks of their respective companies. Conen disclaims any and all rights in these marks.

Specifications are subject to change without notice. We accept no responsibility for typographical errors or omissions to the information.

Copyright 2016 ConenMounts.

Photos: Shutterstock, Inc., Sahara Presentation Systems Plc, Eva Offers, Diane Damaschke

CONEN[®] *mounts*



STP-116-USA

Distributed by:

Stirling Communications Supply
29 Poplar Drive
Stirling, NJ 07980
USA

E: info@stirlingcomm.com

T: (908) 604-9360