

Mobile electrical height adjustable system
for use with 42"-84" display

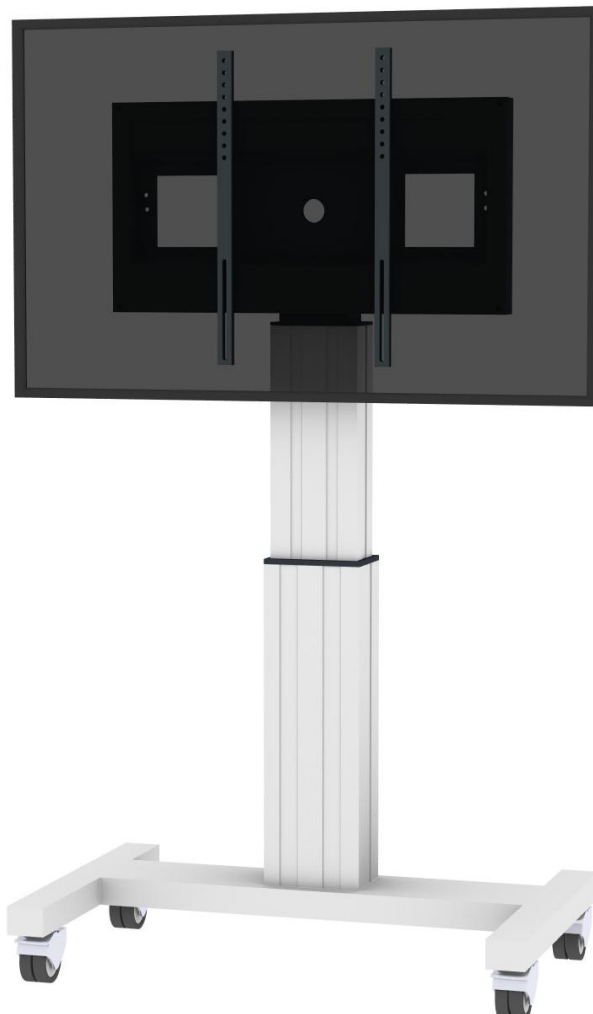

DATA SHEET

Mobile electrical height adjustable system for use with 42"-84" display
 Item no.: SCETA

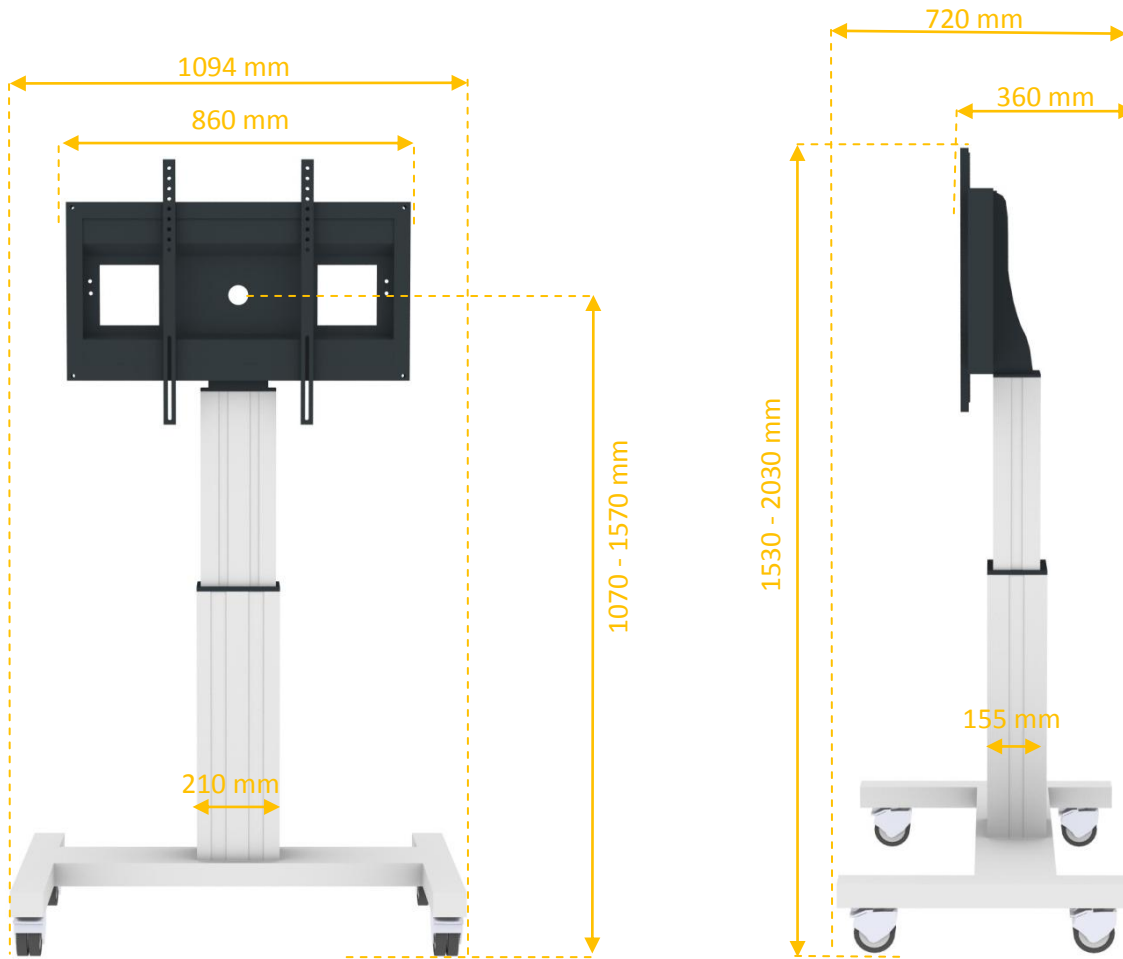

Product features

- electrical height adjustable column, RAL 9006 white aluminum
- 500 mm height adjustment
- Mobile base with four heavy duty casters – two with brakes, H-shape, RAL 9006 white aluminum
- mount for use with 42" – 84" display
- VESA 200 x 200 up to 800 x 600
- maximum load approximately 150 kg



205 Westwood Ave, Long Branch, NJ 07740
 Phone: 866-94 BOARDS (26273) / (732)-222-1511
 Fax: (732)-222-7088 | E-mail: sales@touchboards.com

Packing units

Part no.	Description	Packing dimensions	Net weight	Gross weight
CCE50	Electrical height adjustable column, 500 mm height adjustment	970x280x220 mm	19,5 kg	22,1 kg
AFSCETAN	Display Mount	160 x 870 x 450 mm	12,0 kg	14,0 kg
MSTSCETA	Mobile Base, H-Style	140 x 1130 x 780 mm	12,8 kg	15,5 kg
			44,3 kg	51,6 kg