



ADJUSTABLE WALL MOUNT LIGHT

Classroom technology should not be limited to just a few. ConenMounts motorized Wall Mount Light provides 20" of height adjustment, providing teachers and students an optimum ergonomic and writing position and enabling even those in early grades or in wheelchair to participate.

The wall mount supports 55" – 75" flat panel displays and works by a simple, push-button operation. Because the weight

of the display is supported by the center column, the wall mount allows for the flat panel to be secured to any wall, including stud wall and over an existing dry erase board.

The maintenance-free system complies with the requirements of the ADA standards and is backed by a 5 year warranty.

Key features

- 20" of smooth, motorized height adjustment
- Mounts to any wall and over existing whiteboards
- Supports 55" – 75" displays
- Comes complete with display mount.
- Ships in 1 carton
- Complies with UL 62368-1 standard
- Quick and easy mounting to any wall
- 5 year limited warranty

Technical drawings

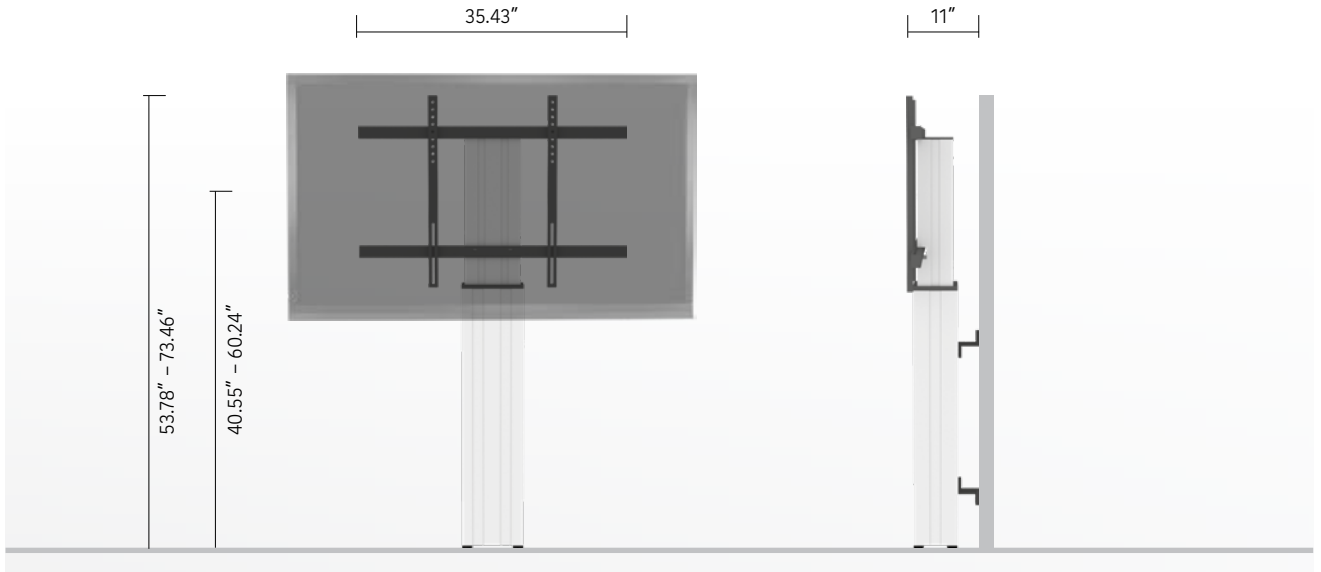

Product Code	SCETA-Lite
Display range	55" - 75"
VESA pattern	up to 800 x 600
Load capacity	250 lbs.
Shipping weight	61 lbs.
Warranty	5 year



Pull & release locking brackets for easier mounting of display



Wired remote control included

Levelling feet and 2 wall mounting brackets for optimum stability

Available accessories



Front shelf

Item# FSH-VG



Floor plate

Item# PST-SCETA-LI



Stud wall mounting bracket

Item# WMB-SCETS-LI

CONEN[®]
mounts

Distributed by:

Stirling Communications Supply
29 Poplar Drive
Stirling, NJ 07980

T: (908) 604-9360
E: DPilar@stirlingcomm.com
www.conenusa.com