



SCETA-TILT-CRXT

MOTORIZED HEIGHT & TILT ADJUSTABLE CART, 28" TRAVEL

Distributed by:

Stirling Communications Supply
29 Poplar Drive
Stirling, NJ 07980

T: (908) 604-9360
E: Sales@Stirlingcomm.com
www.conenusa.com



PRODUCT FEATURES

- ◆ Motorized center column, offering 28" vertical travel
- ◆ 5 year warranty
- ◆ C-shaped mobile stand with four heavy duty castors – two with brakes
- ◆ VESA 200 x 200 up to 800 x 600
- ◆ Fits displays up to 75"
- ◆ Load capacity 300 lbs.

HIGHEST POSITION

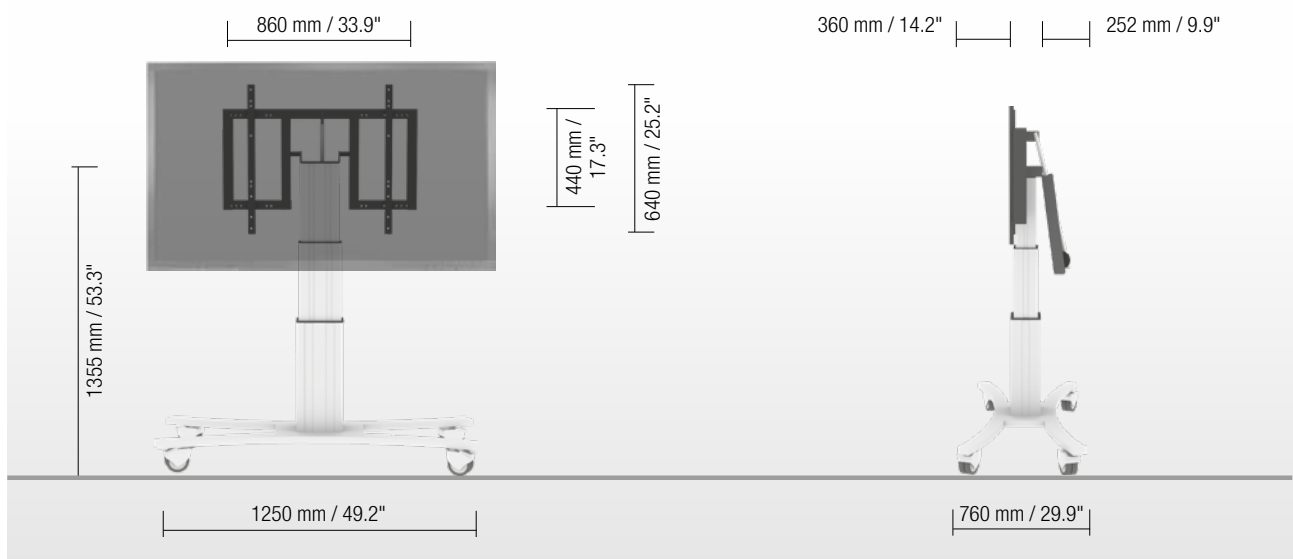

LOWEST POSITION

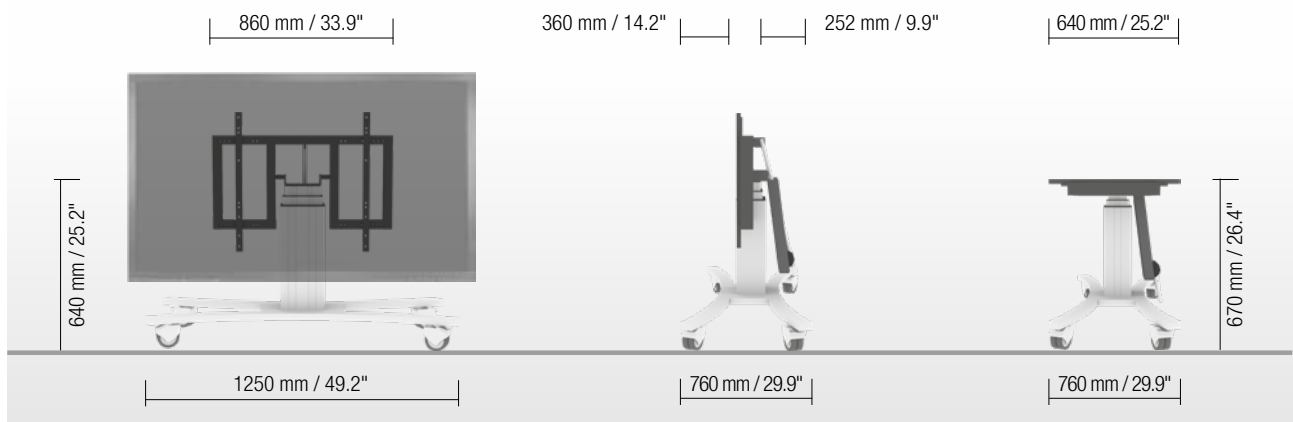

DETAIL VIEWS



Sturdy display mount



Tilt function



Smooth running & lockable castors



Wired remote control

AVAILABLE ACCESSORIES



LAP4-..

Side shelf



FSH-..

Front shelf



MINI-FUJI

Lockable mini PC bracket

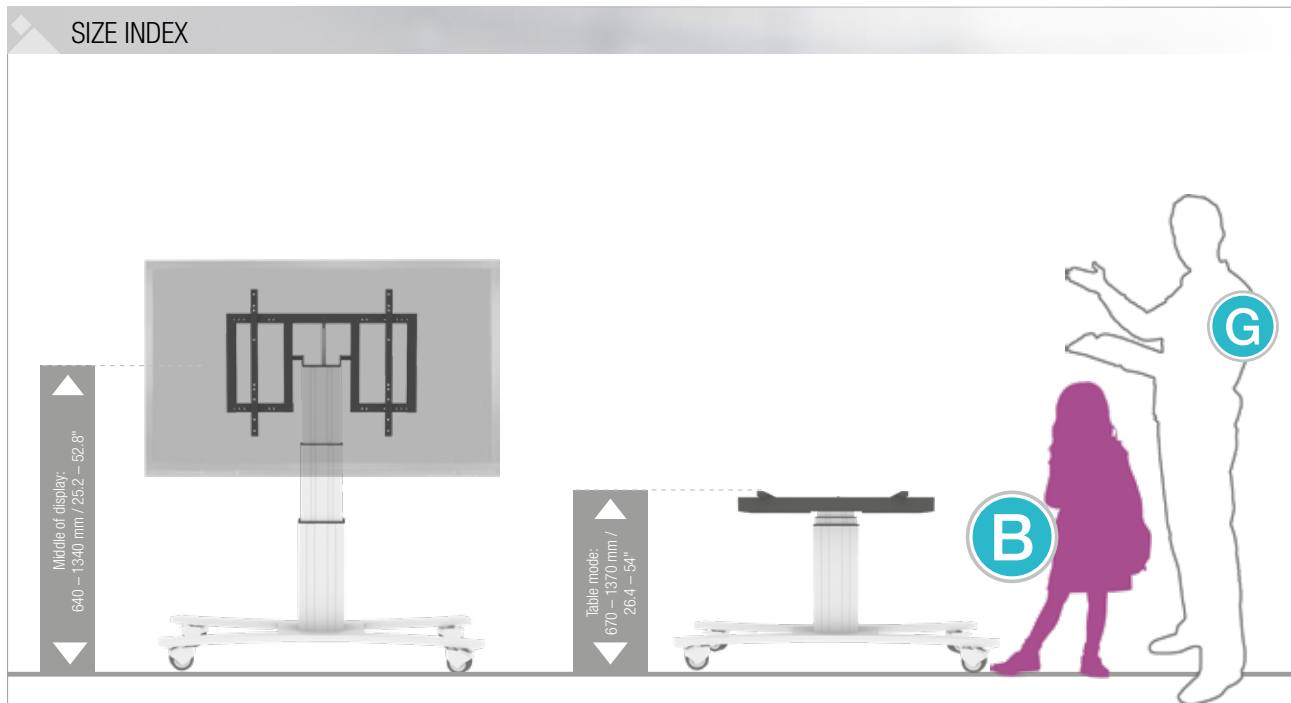

Educational level	Kindergarten			Primary school			Adults
	A	B	C	D	E	F	G
Silhouette	A	B	C	D	E	F	G
Age (years)	2 – 3	3 – 4	4 – 7	6 – 11	11 – 14	13 – 16	from 16
Body height (mm / ")	930 – 980 37 – 38.6	1080 – 1210 42.5 – 47.6	1190 – 1420 46.9 – 56	1330 – 1590 52.4 – 62.6	1460 – 1765 57.5 – 69.5	1590 – 1880 62.6 – 74	1740 – 2070 68.5 – 81.5
Color	Green	Purple	Yellow	Red	Green	Blue	

PACKING UNITS				
Item no.	Description	Packing dimensions (mm / ")	Net weight (kg / lbs)	Gross weight (kg / lbs)
CCET-3535	Motorized adjustable column, 700 mm / 27.6" height adjustment	820 x 270 x 220 / 32.3 x 10.6 x 8.7	21,2 / 45.9	24,0 / 53
AF-SCETTABL	Display mount with tilt actuator	890 x 770 x 480 / 35 x 30.3 x 18.9	22,1 / 48.7	26,8 / 59.1
MST-SCETACR	C-shaped mobile base, recessed	1350 x 780 x 120 / 53.1 x 30.7 x 4.7	12,8 / 28.2	15,5 / 34.2
Total weight			55,7 / 122.8	66,3 / 146.2