

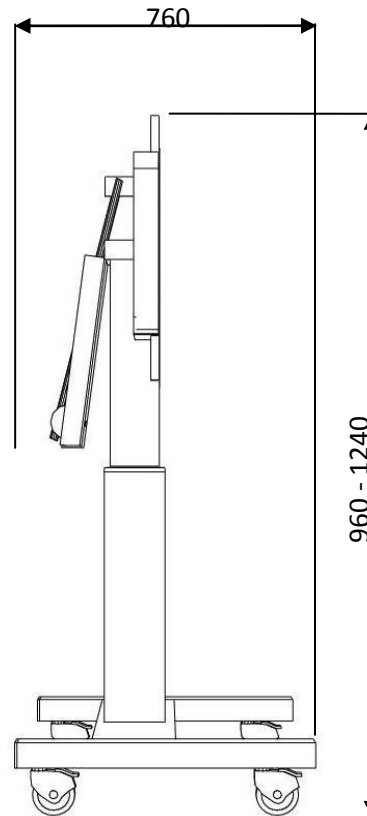

205 Westwood Ave, Long Branch, NJ 07740
Phone: 866-94 BOARDS (26273) / (732)-222-1511
Fax: (732)-222-7088 | E-mail: sales@touchboards.com

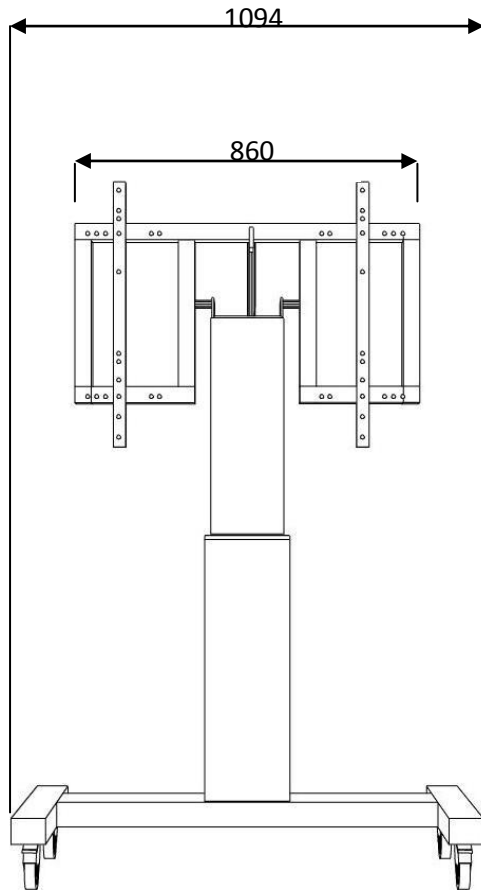

Reference:	SCETTAL
Description:	Motorized mobile cart with tilting display frame. For use with 42"-70" (interactive) Flat-Panel Display
Consists of:	AFSCETTA display frame with external actuator for tilt CCET28 motorized center column, H:50cm/20" MSTSCETA mobile stand
Weight capacity	120 kg / 265 lbs
System weight	62 kg / 137 lbs

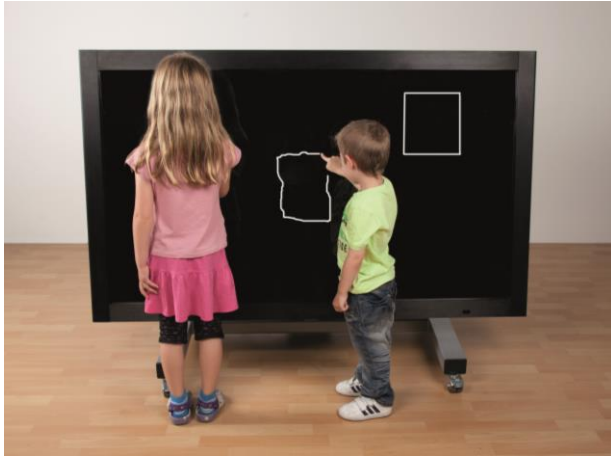

6 year old girl and 4 year old boy (lowest position)



10 year old boy (highest position)



10 year old boy (lowest position)



Teacher (highest position)

