

SCETTA

Mobile cart with motorized height adjustment & tilt

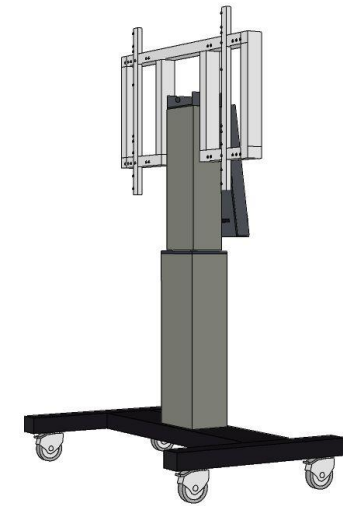

Product reference:	SCETTA
Product description	mobile stand with motorized height adjustment and tilting display frame. For 42"-70" (interactive) Flat-Panel Display
Consists of:	AFSCETTA display frame with external actuator for tilt CCET50 motorized center column MSTSCETA mobile stand
Weight capacity:	120 kg / 265 lbs
Net system weight:	67 kg / 147 lbs

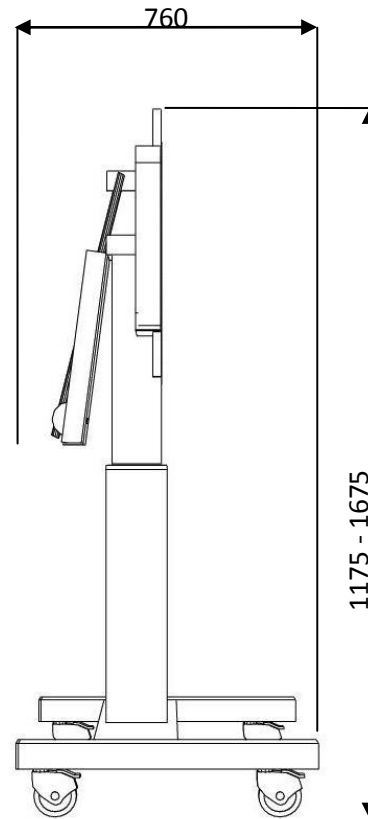
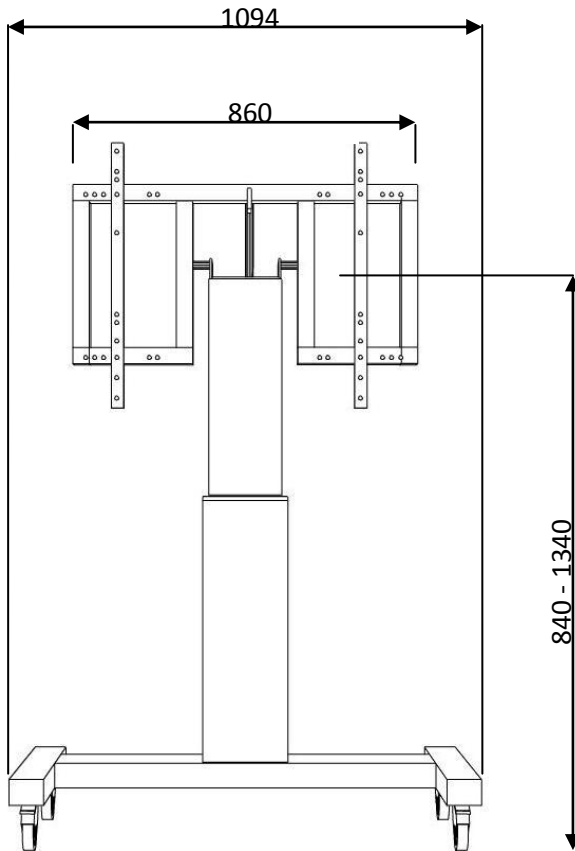