

Maximum load rating: 50 lbs

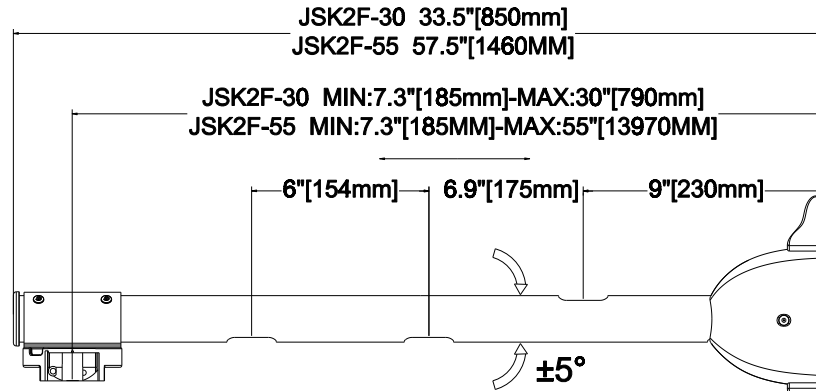

205 Westwood Ave, Long Branch, NJ 07740
 Phone: 866-94 BOARDS (26273) / (732)-222-1511
 Fax: (732)-222-7088 | E-mail: sales@touchboards.com

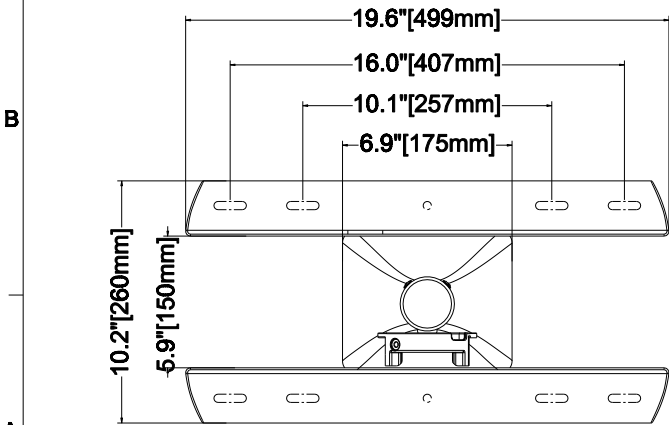
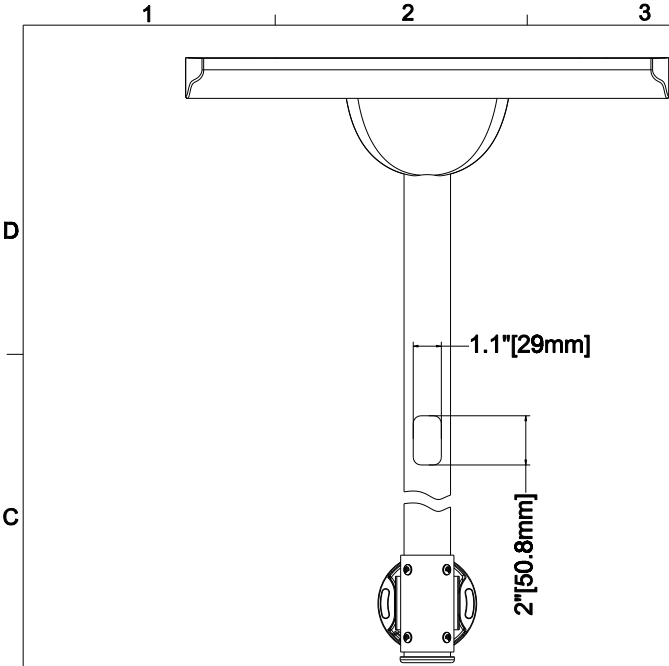
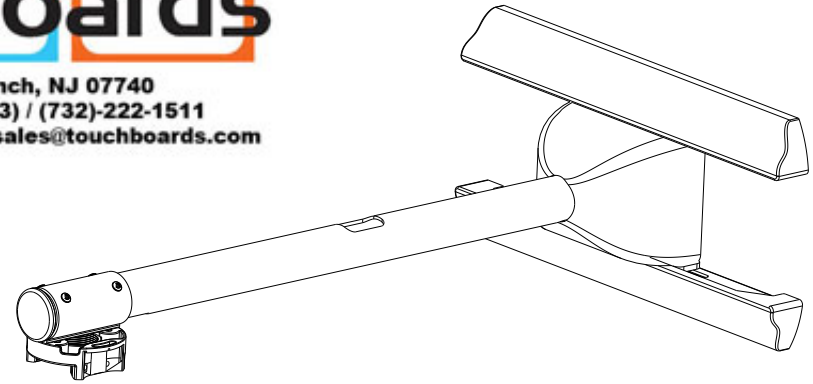

THE INFORMATION CONTAINED IN THIS DRAWING IS THE SOLE PROPERTY OF CRIMSON AV LLC. ANY REPRODUCTION IN PART OR AS A WHOLE WITHOUT THE WRITTEN PERMISSION OF CRIMSON AV LLC IS PROHIBITED

CRIMSON AV LLC.

PRODUCT ORDER NUMBER: **JSK2F-30/55**
 PHONE: **1-866-668-6888**

Scale=1:1

| | |
|--------------------------------------|----------------------------|
| Crimson AV LLC. www.crimsonav.com | |
| TITLE: JSK2F-30/55 | |
| SIZE B | DWG.NO. JSK2F-30/55 |