

DMP
 4 Tools Precision Station with Electric Pump
 Ref.: **DMPSE-9QB** 100V
DMPSE-1QB 120V
DMPSE-2QB 230V

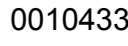

SPARE PARTS	
DMU CONTROL UNIT:	
-CIRCUIT	0028821
-ENCLOSURE	
· TOP	0019028
· BOTTOM	0026182
· FRONT+DISPLAY	0026184
· BACK	0026183
MSE ELECTRIC DESOLDERING MODULE:	
-CIRCUIT	0018453
-ENCLOSURE	
· TOP	0015266
· BOTTOM	0022642
· FRONT	0014688
· BACK	0015261
-PUMP	0005652

Ref.: **DMPSE-9QB** 100V FUSE T-8A
DMPSE-1QB 120V FUSE T-6A
DMPSE-2QB 230V FUSE T-3,15A

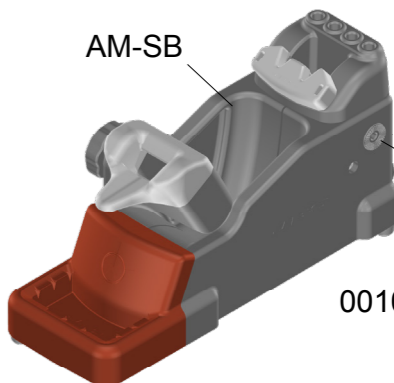
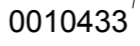
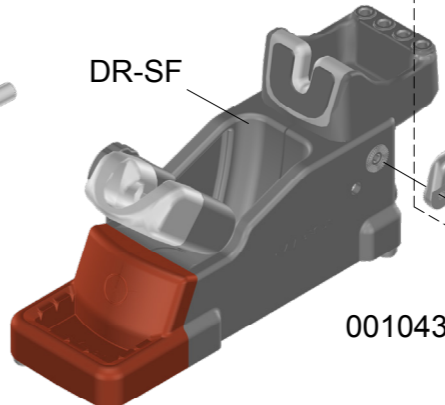
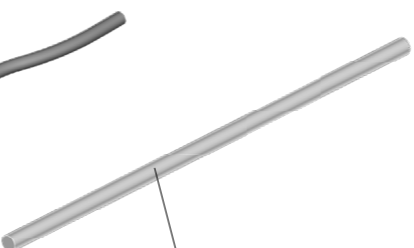
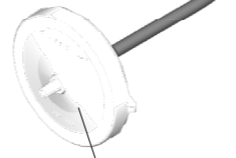
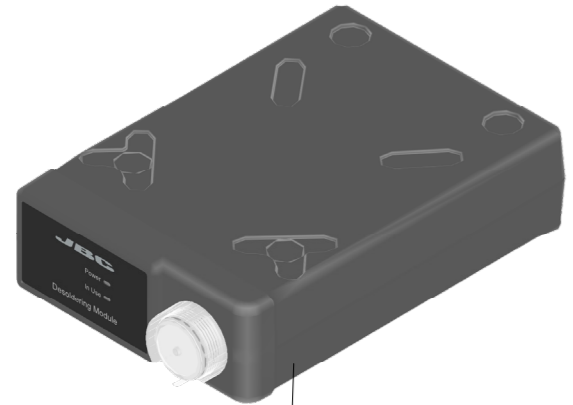
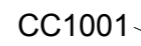
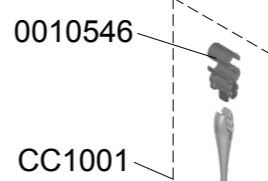
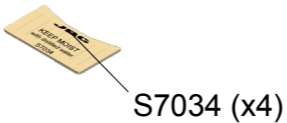
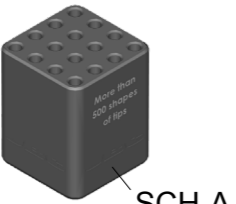
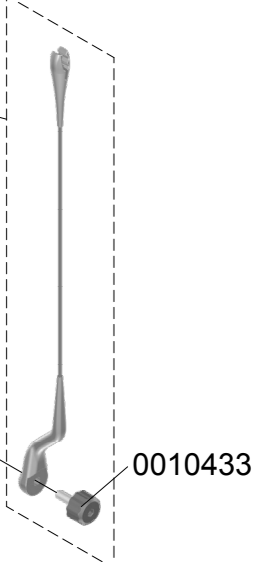
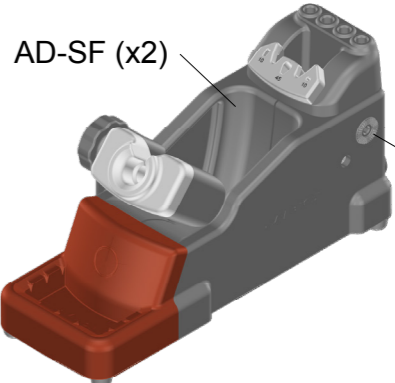
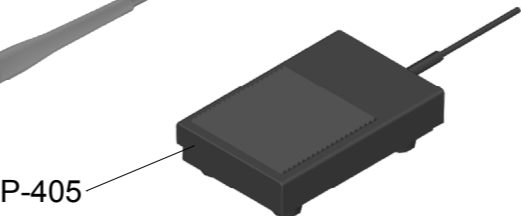
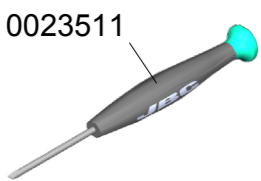
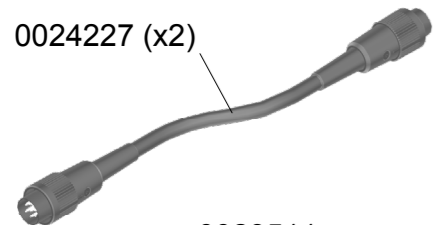
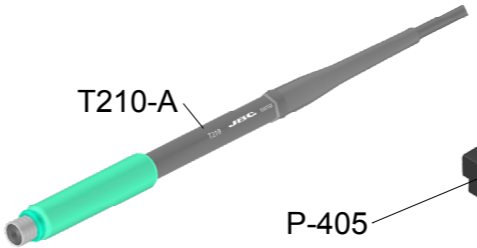
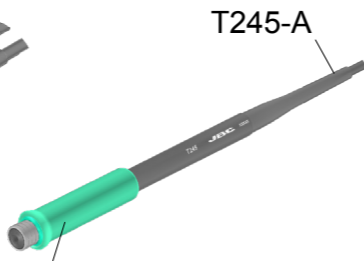
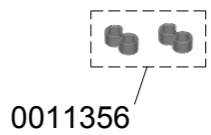
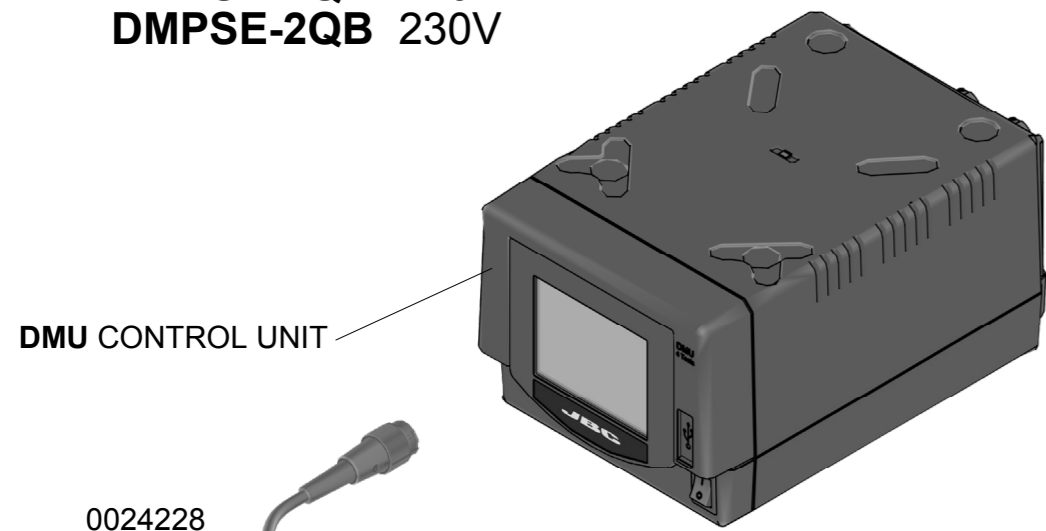
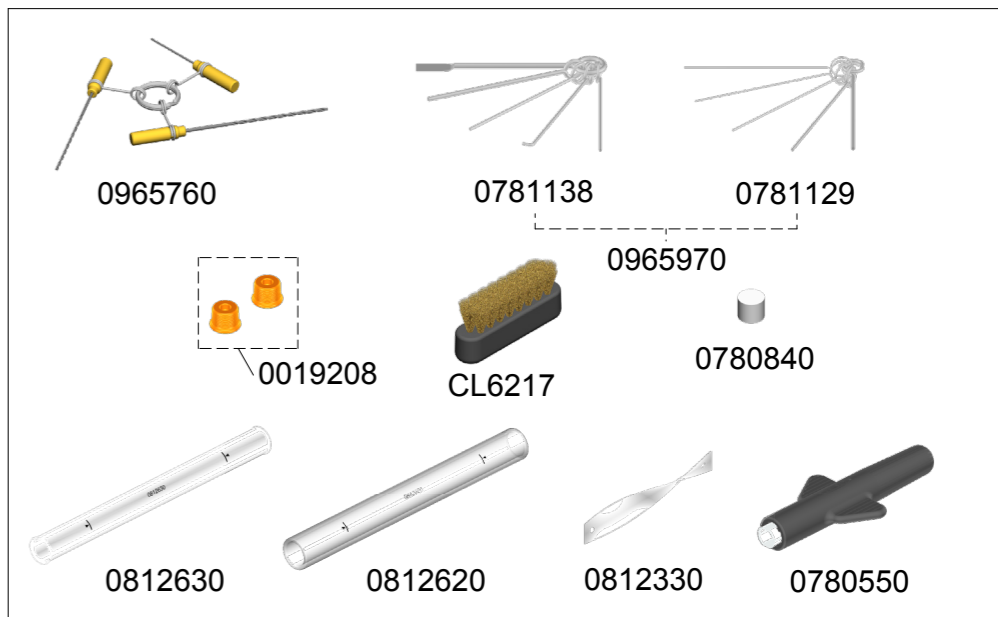

0022820