

peerless-AV[®]

DS-C555-3X3

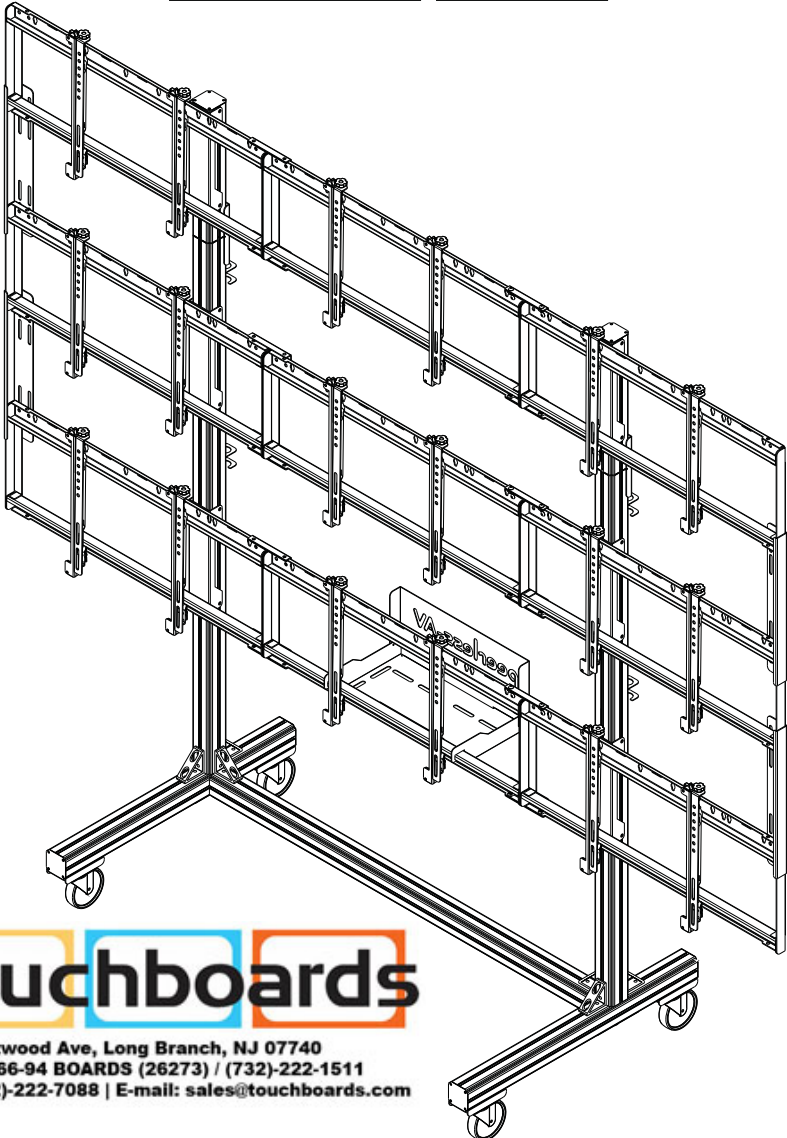
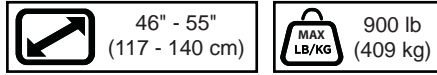

Touchboards

205 Westwood Ave, Long Branch, NJ 07740
Phone: 866-94 BOARDS (26273) / (732)-222-1511
Fax: (732)-222-7088 | E-mail: sales@touchboards.com

ENG



This page intentionally left blank.

⚠ WARNING

Do not begin to install product until you have read and understood the instructions and warnings contained in this user guide. Always use an assistant or mechanical lifting equipment to safely lift and position equipment. This product must be installed onto flat, hard, level surface to prevent tipping. The cart or stand is not affixed or secured to the floor, and may therefore tip over and/or fall if screen and/or stand is shaken or hit. Displays must be removed before moving cart. Not recommended for use in areas with heavy traffic. This product is intended for indoor use only. Use of this product outdoors could lead to product failure or personal injury. Screws must be tightly secured. Do not overtighten screws or damage can occur and product may fail. Never exceed the Maximum Load Capacity. Be careful not to pinch fingers when operating the mount. For support please call customer care at 1-800-865-2112.

[ENG] Symbols



[ENG] WARNING

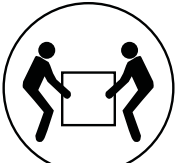

Heavy



[ENG] Screws must get at least three full turns and fit snug.



[ENG] Display center.

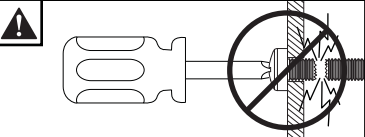

[ENG] Do not overtighten screws.

[ENG] Tools Needed for Assembly.

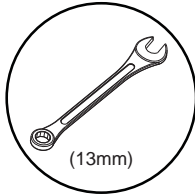
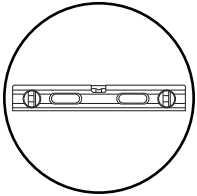

(13mm)



To properly tighten screws: Tighten until screw head makes contact, then tighten another 1/2 turn. Do not overtighten screws.

1

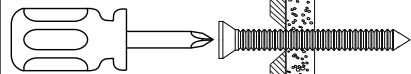

2

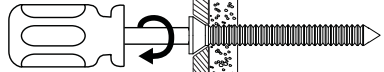

3

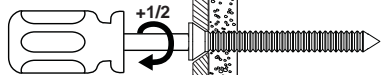

4



Parts (Before beginning, make sure you have all parts shown below).

Parts List

Description	Qty	Part #
A caster, 5" swivel	4	600-0026
B caster support	4	145-T1799
C cover	6	145-T1809
D base leg	2	145-T1767
E horizontal leg support	1	145-T1785
F base support tube	2	145-T1812
G base support	6	560-T1261
H vertical leg support	2	145-T1777
I leg support extension	2	145-T1778
J adaptor bracket	18	145-T1792
K side support bracket	4	145-T1807
L vertical support bracket	6	145-T1806
M computer cover	1	145-T1930
N computer shelf	1	145-T1931
O dual cross support	3	145-T1924
P extension adaptor	2	145-T1935
Q locking tab	4	145-T1936
R cord bracket	4	145-T1929
S cross support	3	145-T1816
T plate connections	6	145-T1821
U M8 x 16mm socket button screw	168	520-9527
V M8 square nut	92	530-1066
W cover clip	24	590-0317
X M5 x 10mm type-F, socket pin screw	20	520-1164
Y M5 x 12mm socket pin screw	4	520-1064
Z 1/4" power bit	1	560-0263
AA 5mm allen wrench	1	560-9640
BB nylon shoulder washer	36	590-2233
CC M6 x 12mm socket pin screw	36	520-1050
DD 4mm allen wrench	1	560-9646

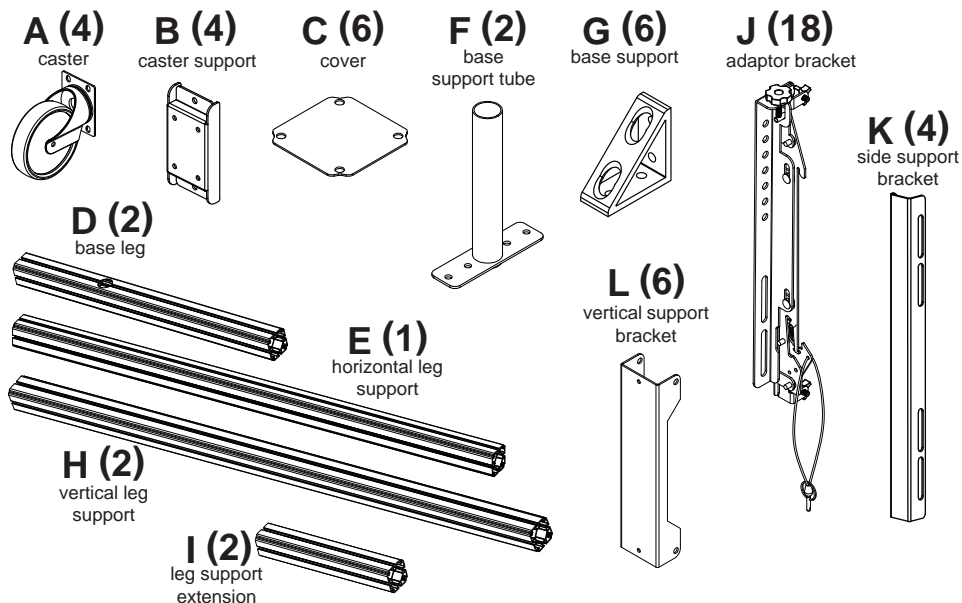

O (3)

dual cross support

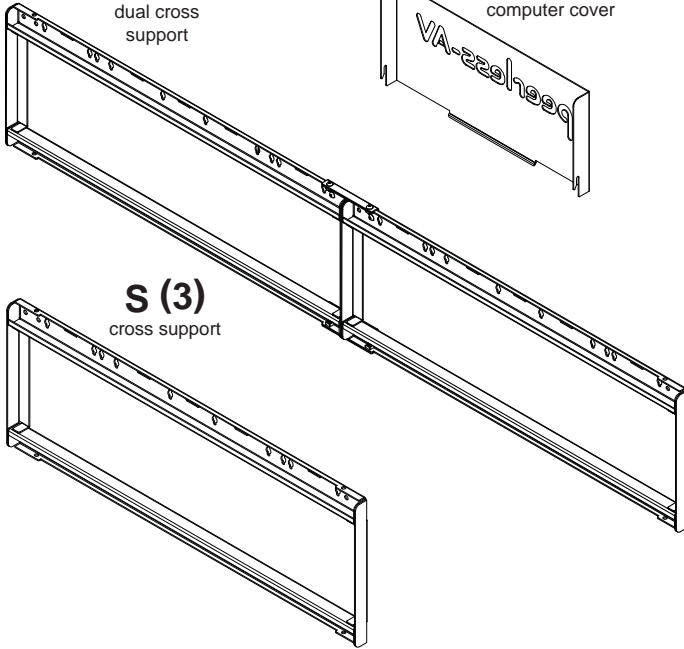

M (1)

computer cover

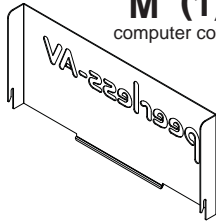

N (1)

computer shelf

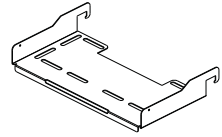

S (3)

cross support

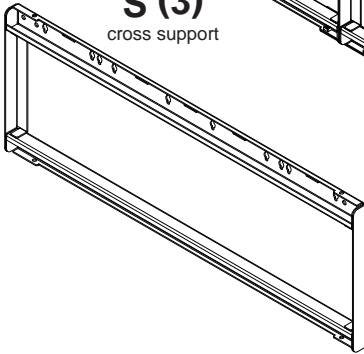

P (2)

extension adaptor

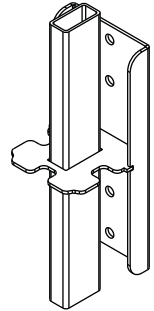

Q (4)

locking tab

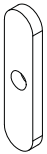

R (4)

cord bracket

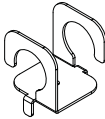

T (6)

plate connections

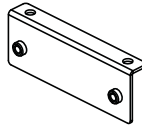

U (168)

M8 x 16mm

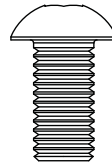

V (92)

M8 square nut

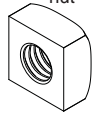

W (24)

cover clip

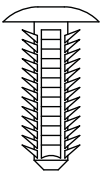

X (20)

M5 x 10mm

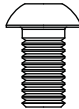

Y (4)

M5 x 16mm



Z (1)

1/4" power bit

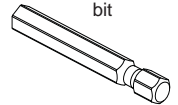

AA (1)

5mm allen wrench

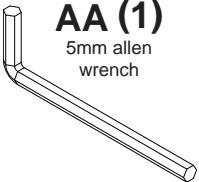

BB (36)

nylon shoulder washer

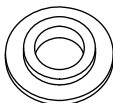

CC (36)

M6 x 12mm

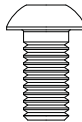

DD (1)

4mm allen wrench

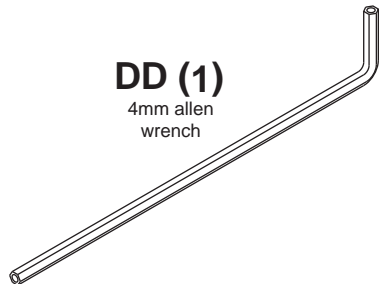

1

Repeat for each caster assembly.

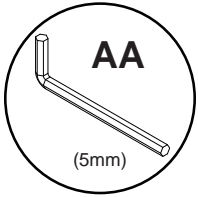

U (4)

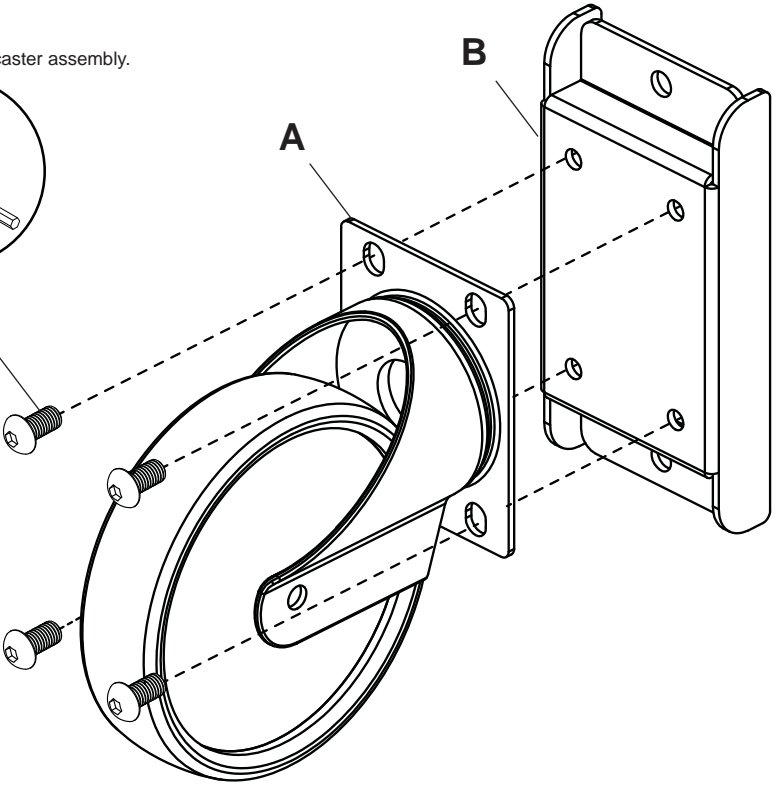

V (2)

U (2)

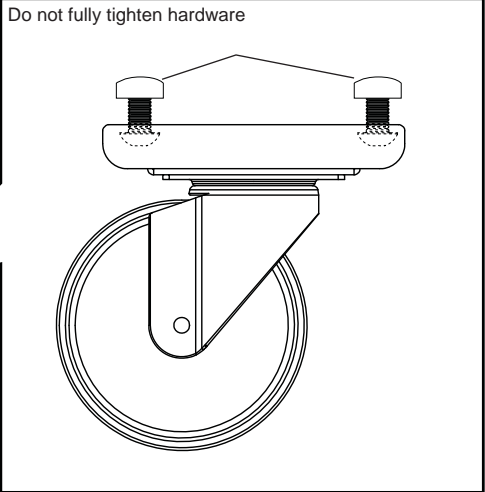
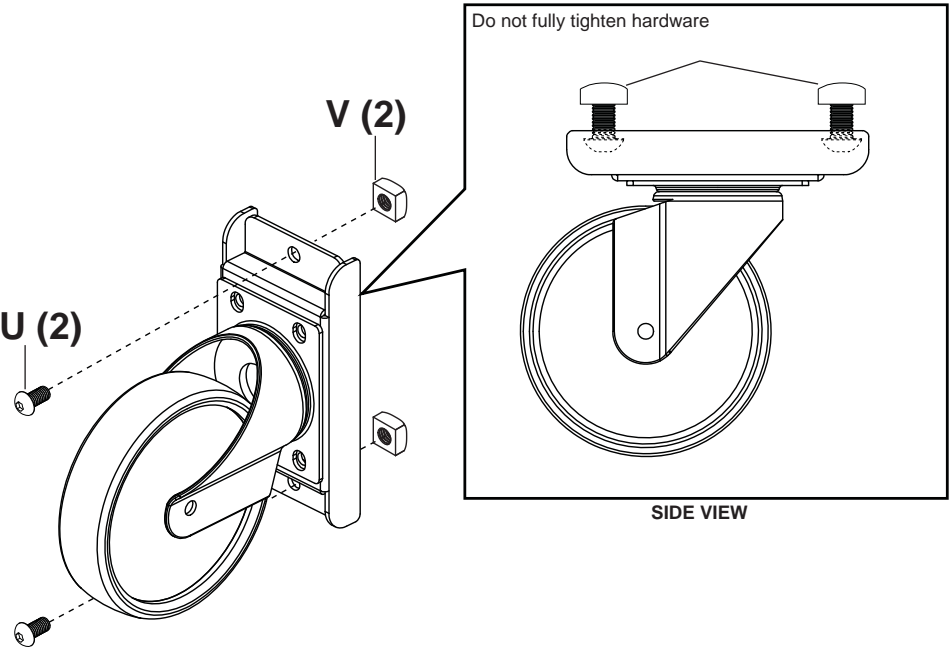

SIDE VIEW

Repeat for each base leg assembly.

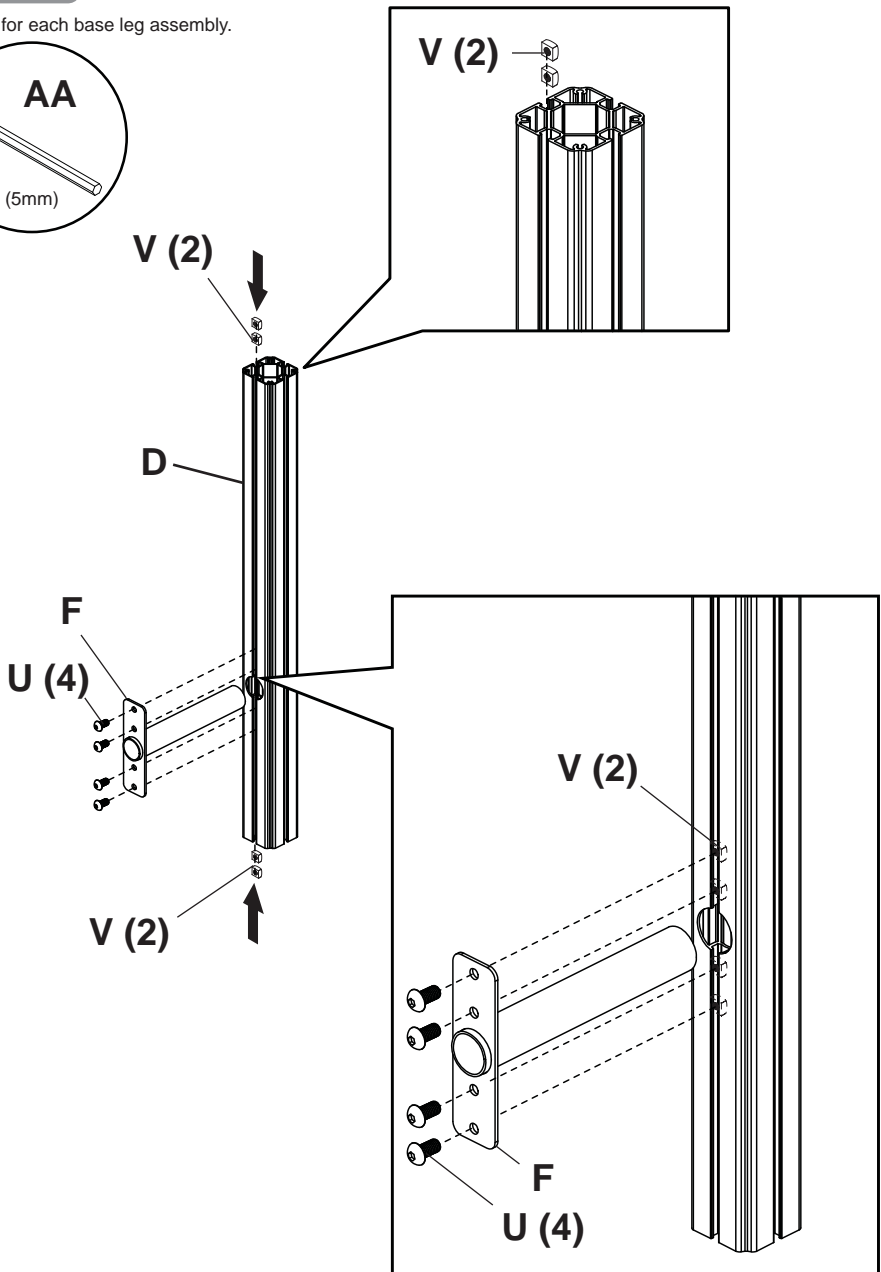
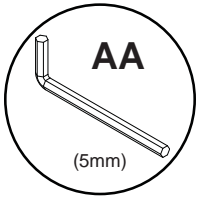

Repeat for each base leg assembly.

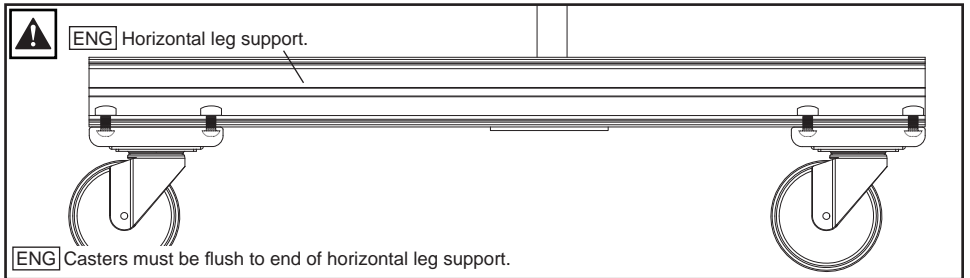
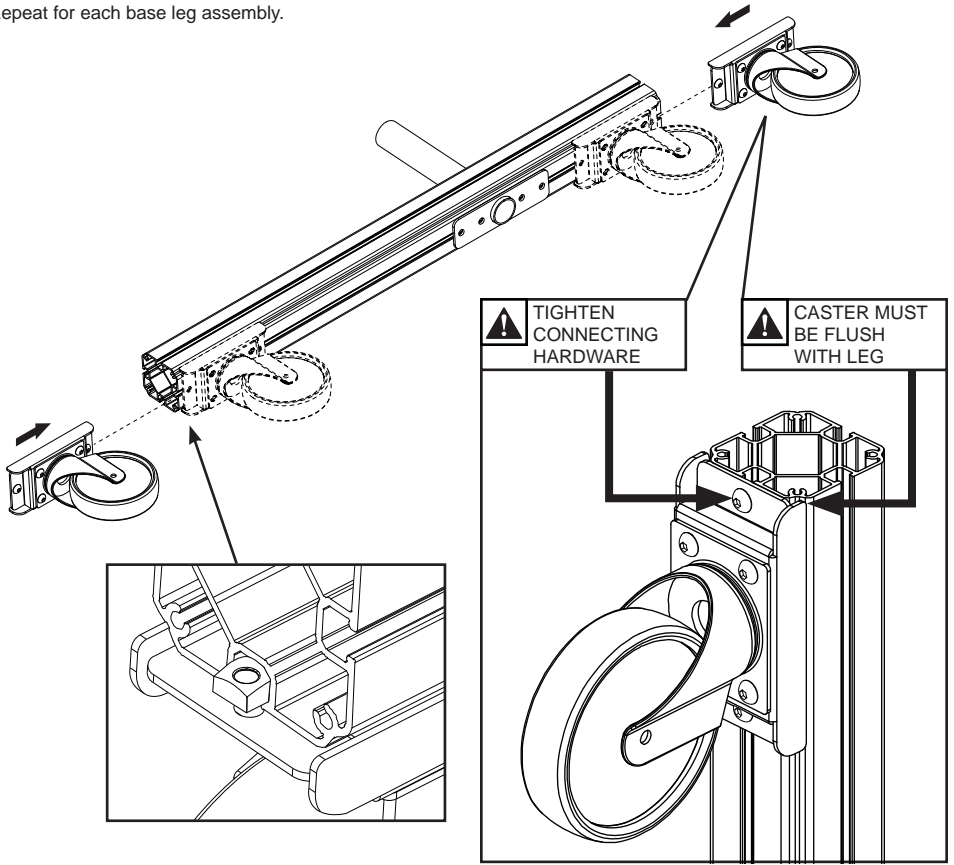

4

Repeat for each base support (x6).

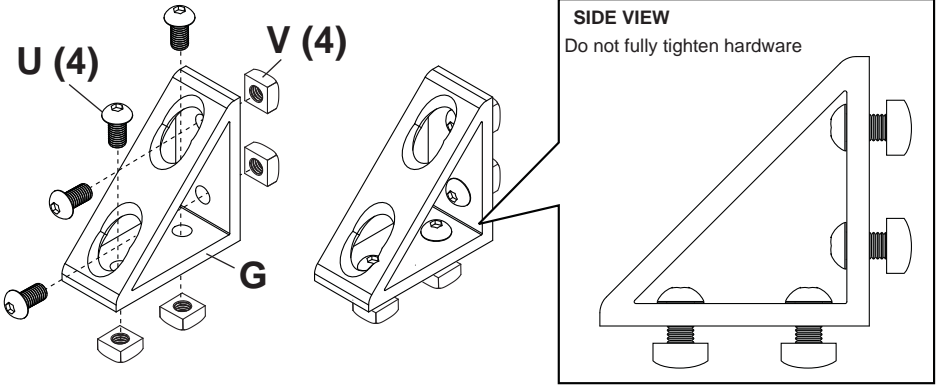

5

Repeat for each side (x2).

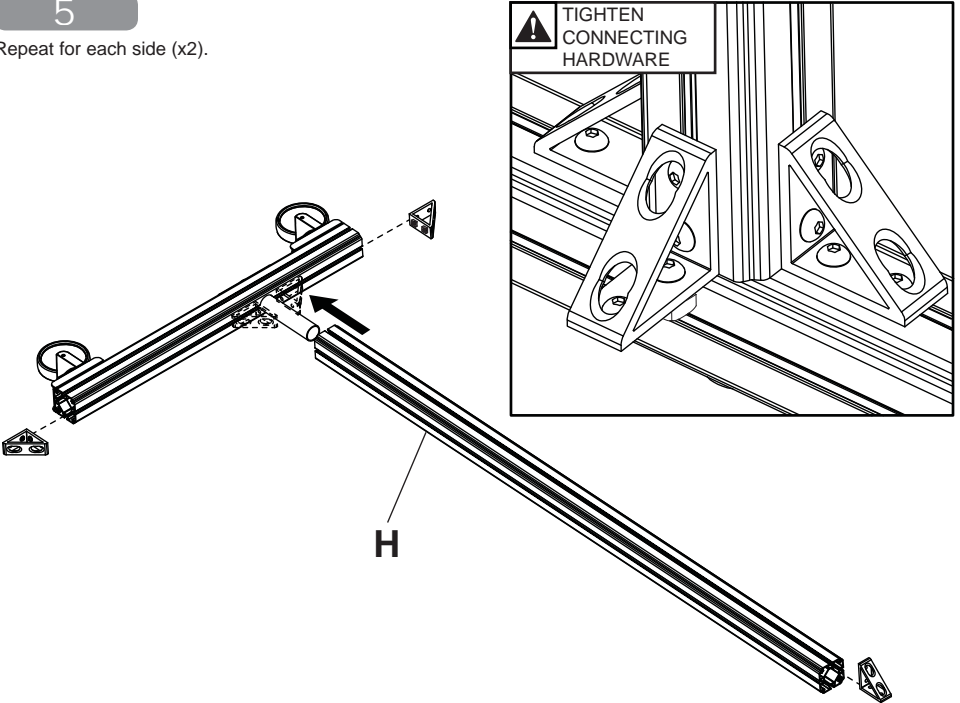

6

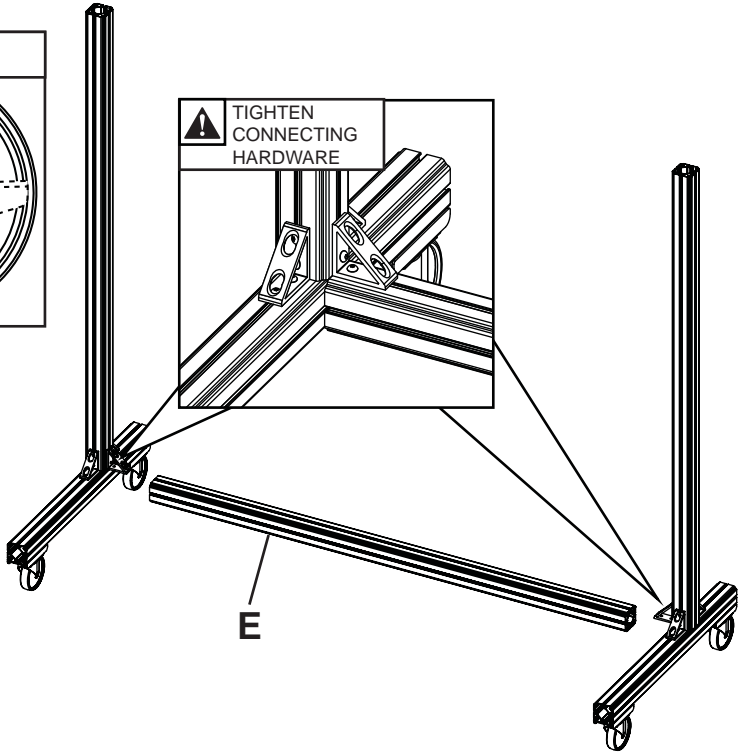
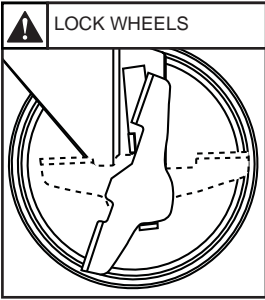

7-1

Do not fully tighten hardware.

Repeat for each extension adaptor (x2).

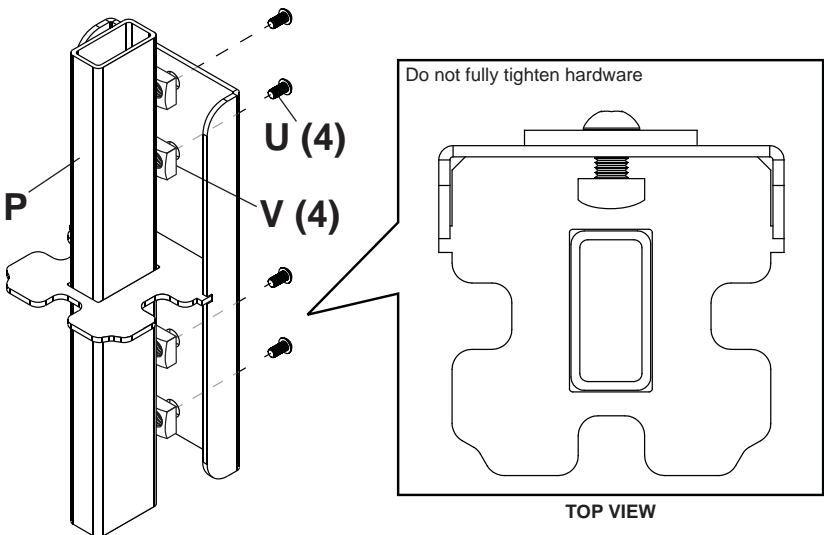

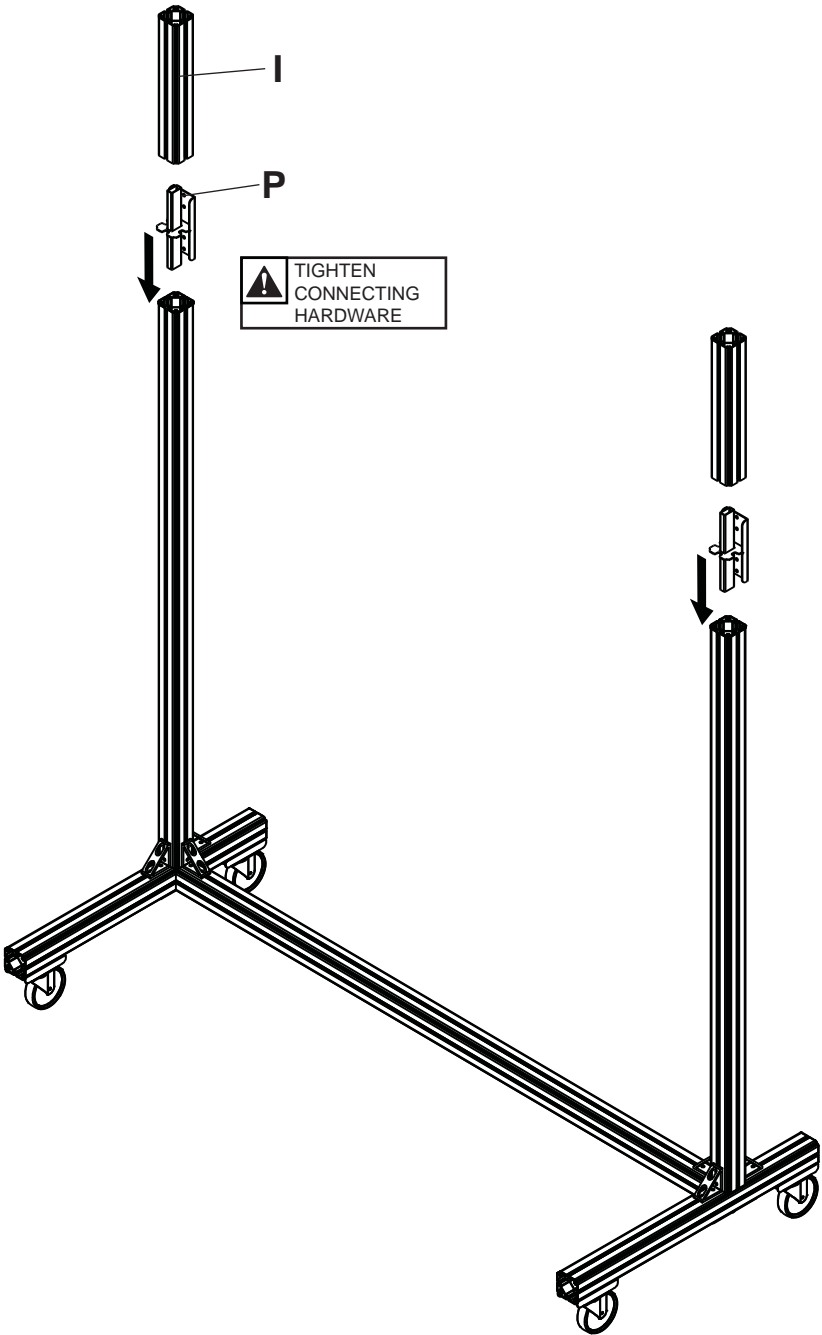

Repeat for each vertical support bracket (x6).

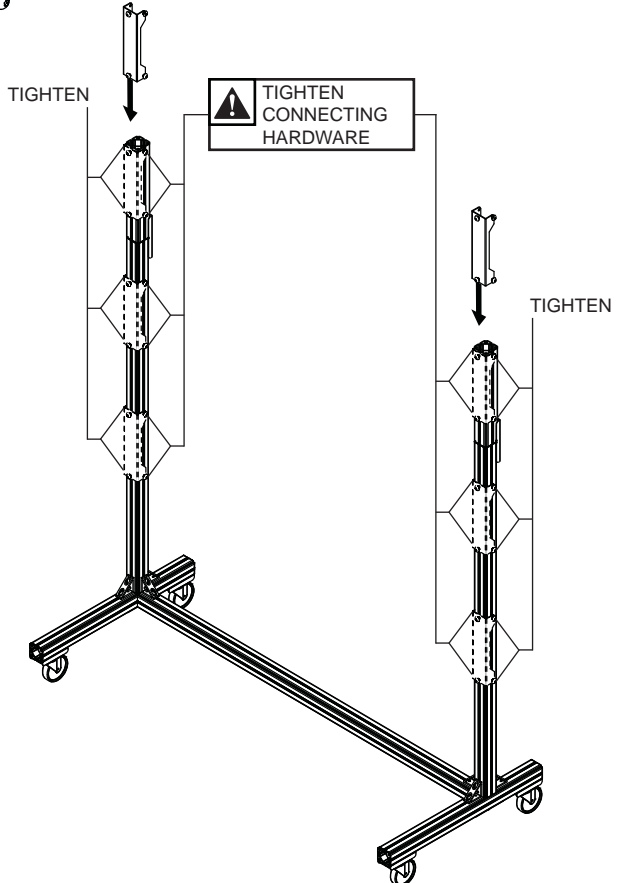
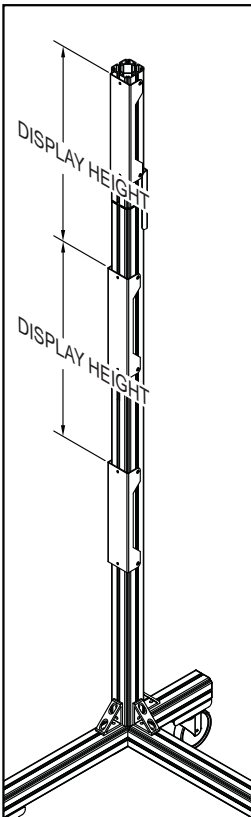
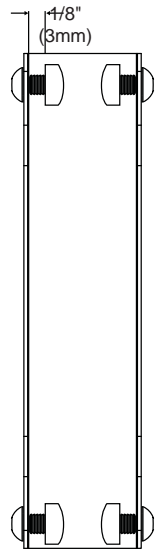
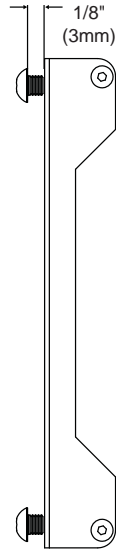
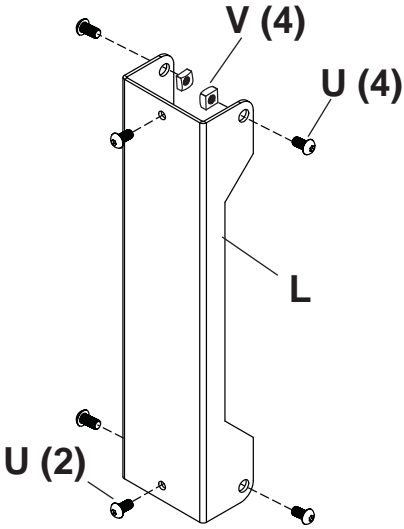

Repeat for each cross support (x3).

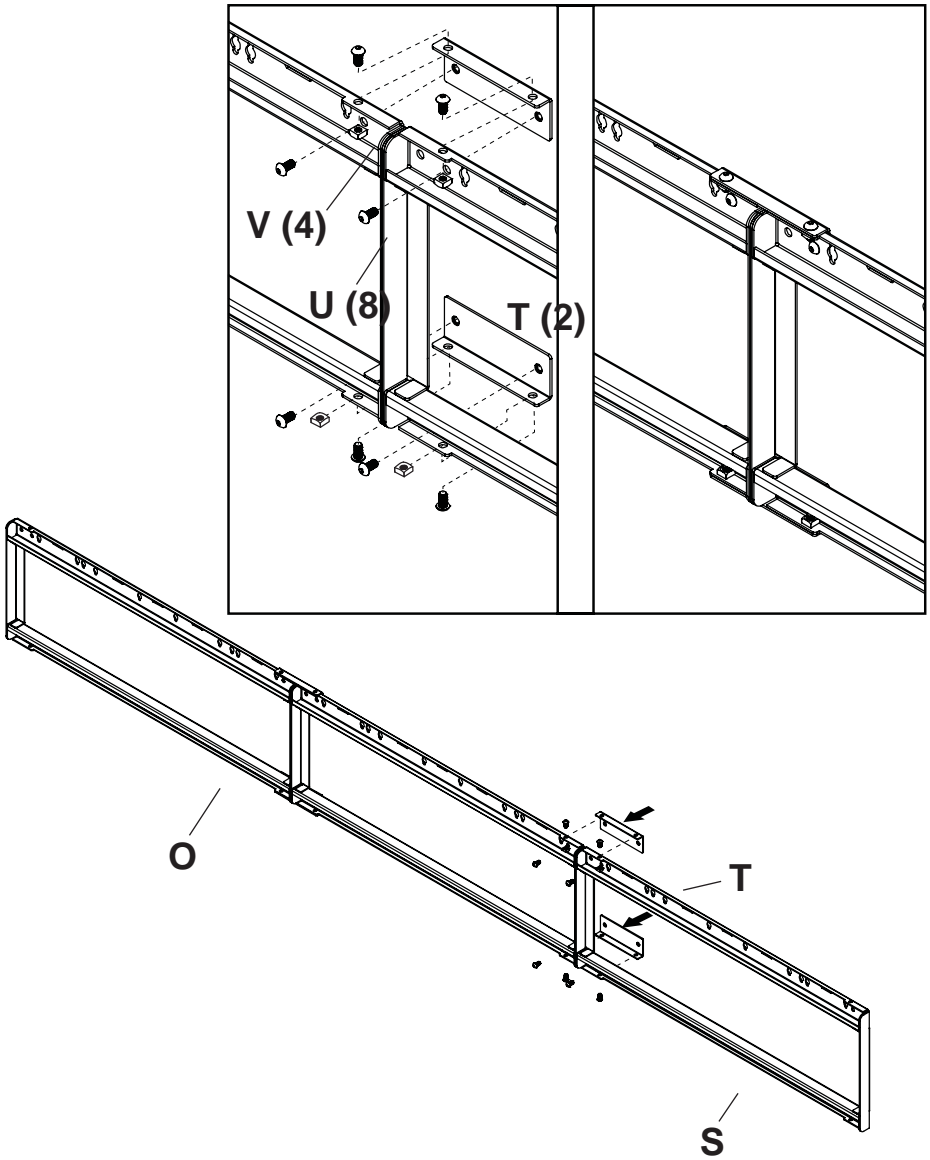

Must install bottom row first.

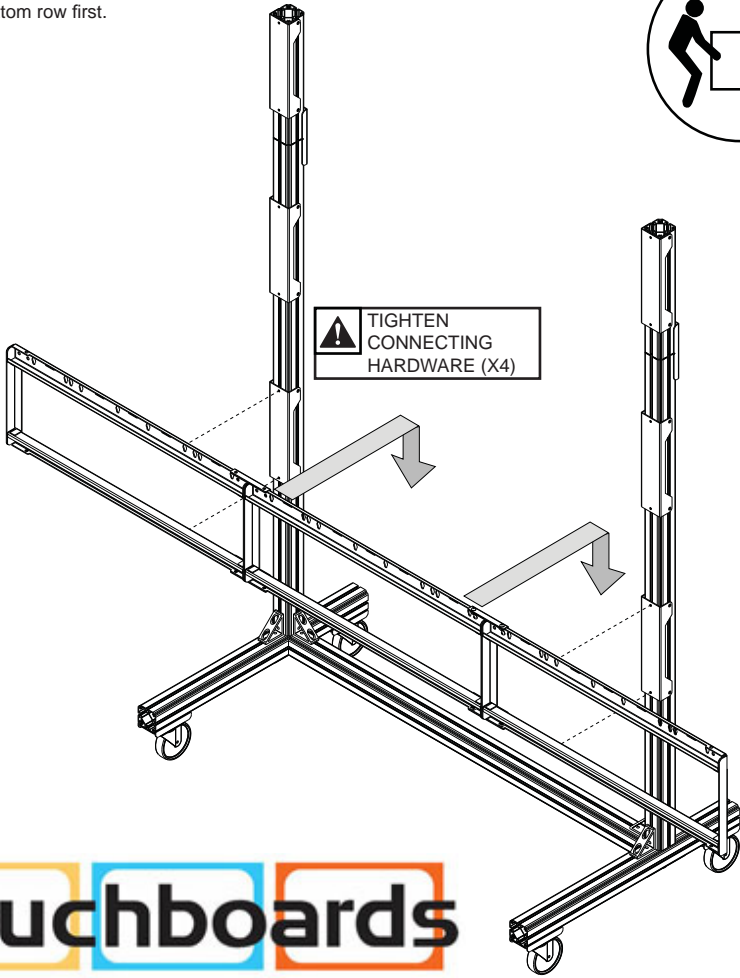
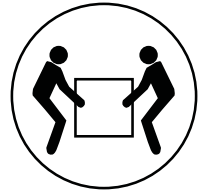

Touchboards

205 Westwood Ave, Long Branch, NJ 07740
Phone: 866-94 BOARDS (26273) / (732)-222-1511
Fax: (732)-222-7088 | E-mail: sales@touchboards.com

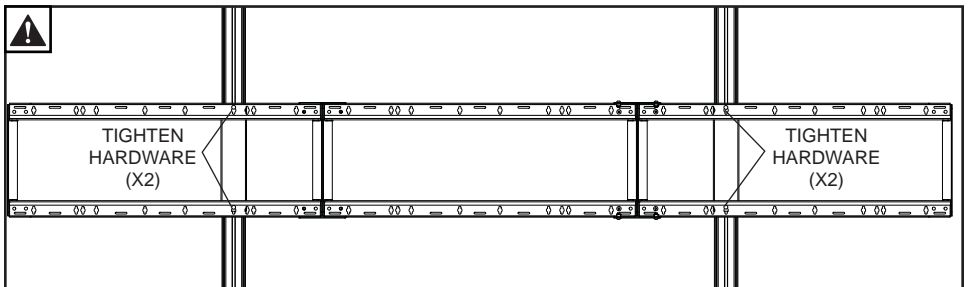

Cross supports must center on vertical leg supports.

Must install middle row second.

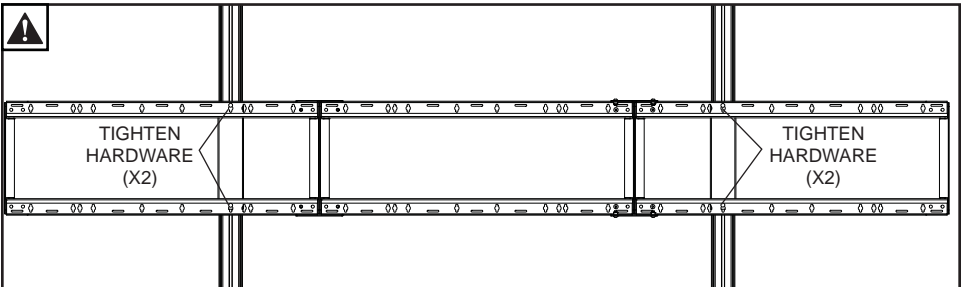
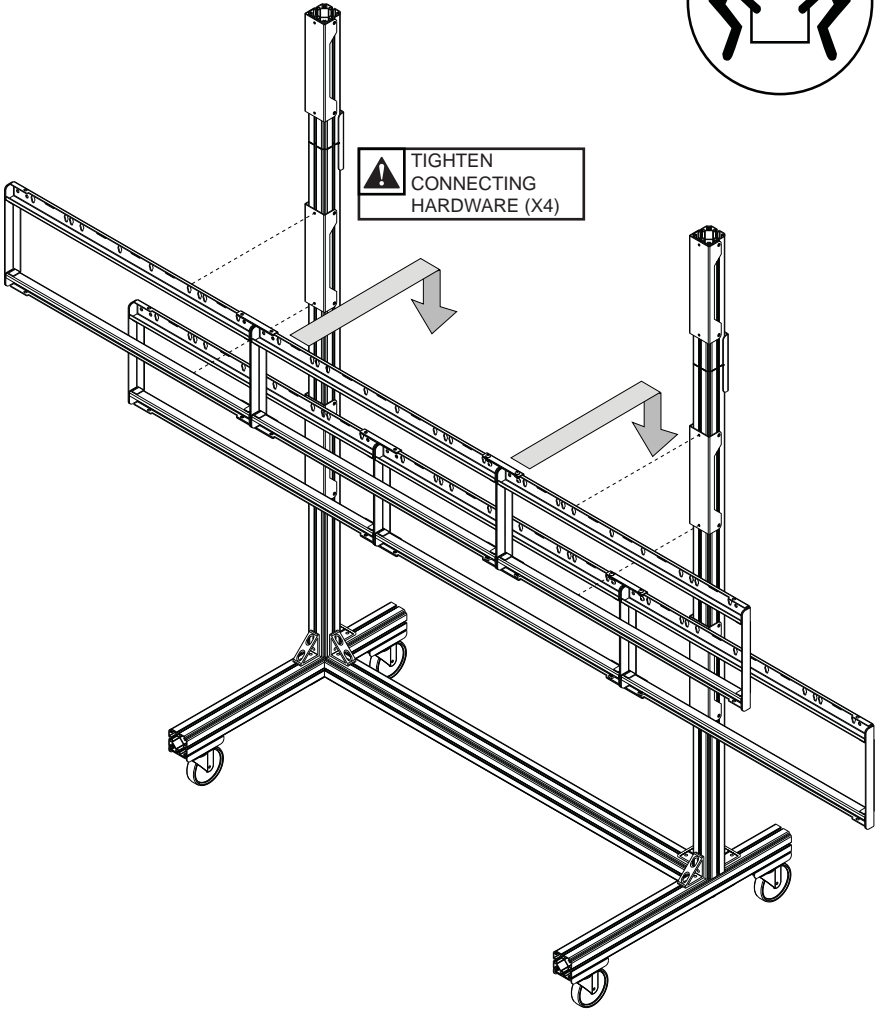
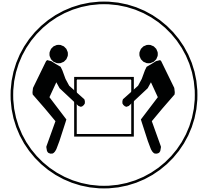

Cross supports must center on vertical leg supports.

Must install top row last.

 TIGHTEN
CONNECTING
HARDWARE (X4)

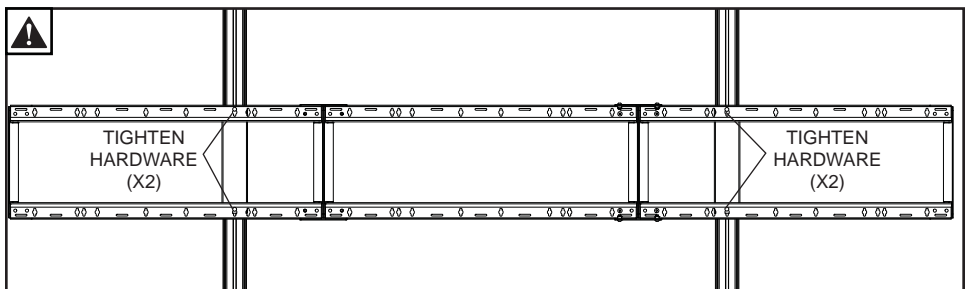
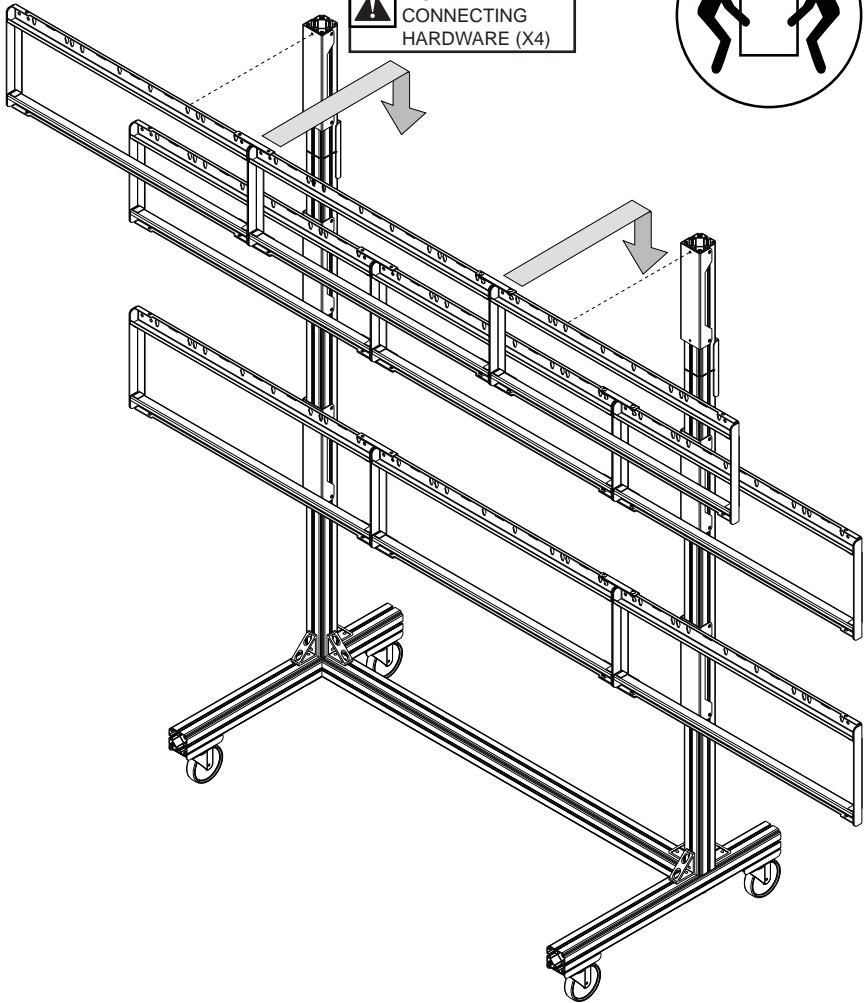
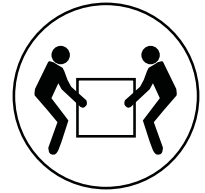

Cross supports must center on vertical leg supports.

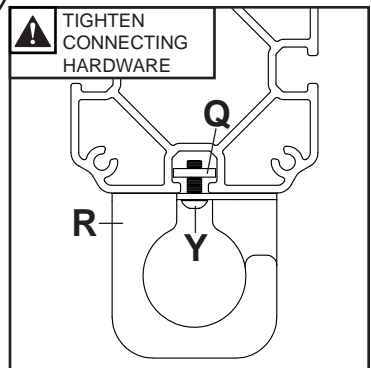
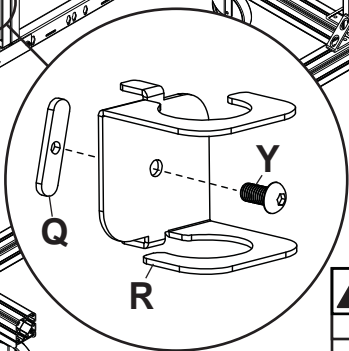
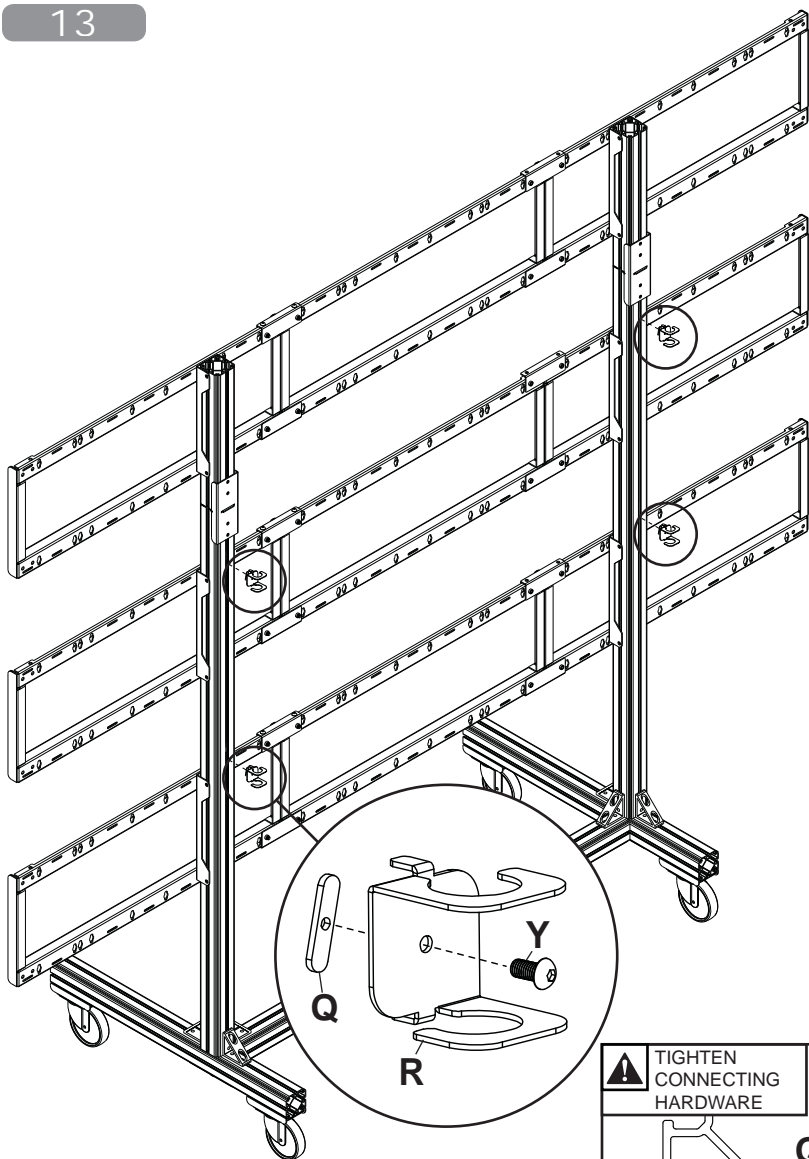

TOP VIEW

Side support brackets (K) must center on cross supports.

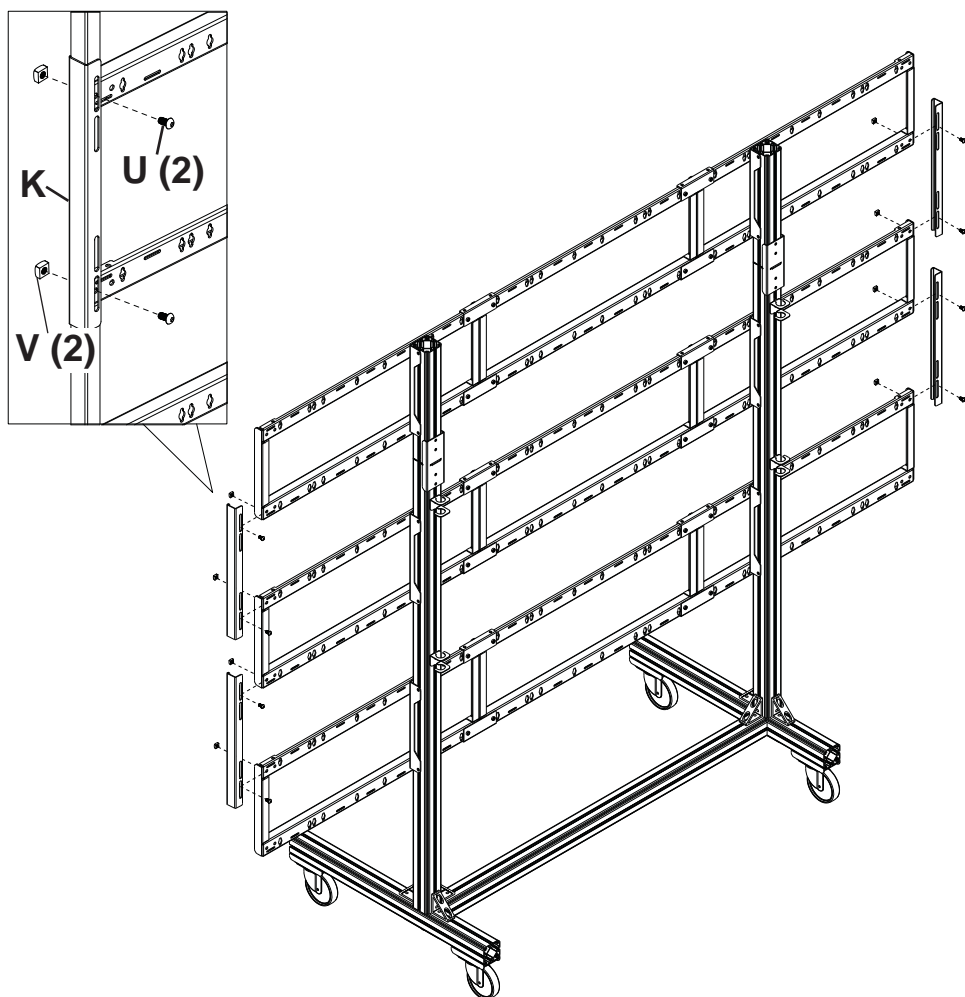

OPTIONAL: Unlock wheels to move cart to desired location; Lock wheels before hanging screens.

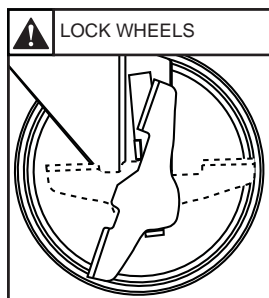

Center adaptor brackets vertically on back of screen.

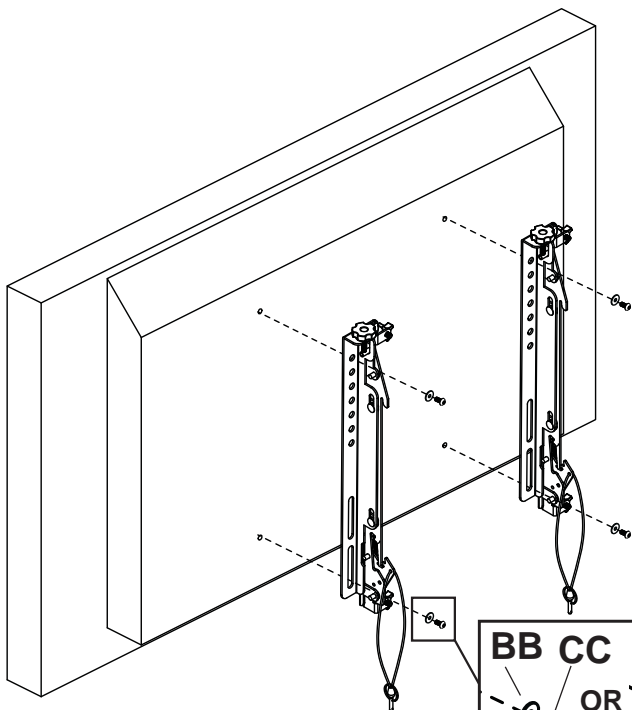
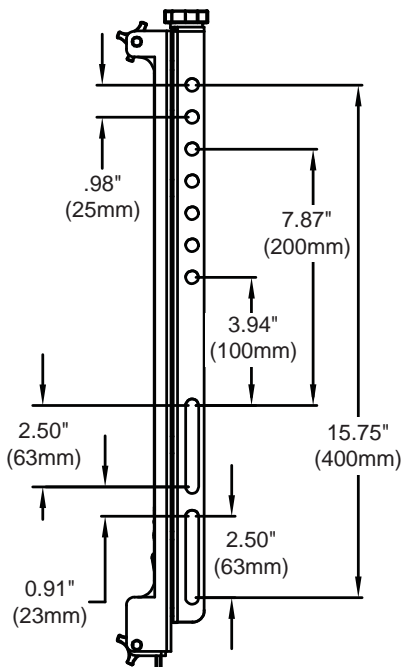
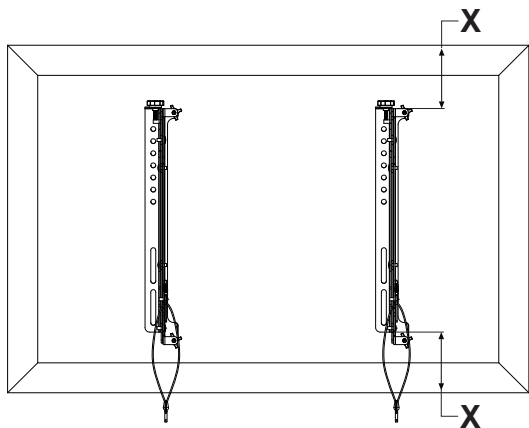

BB	CC	U	<p>X3</p>
OR			

16-1

Must hang displays to bottom row first; Secure pin in "locked" position.

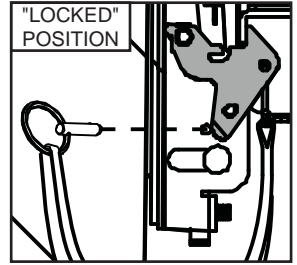
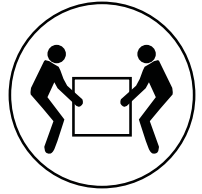
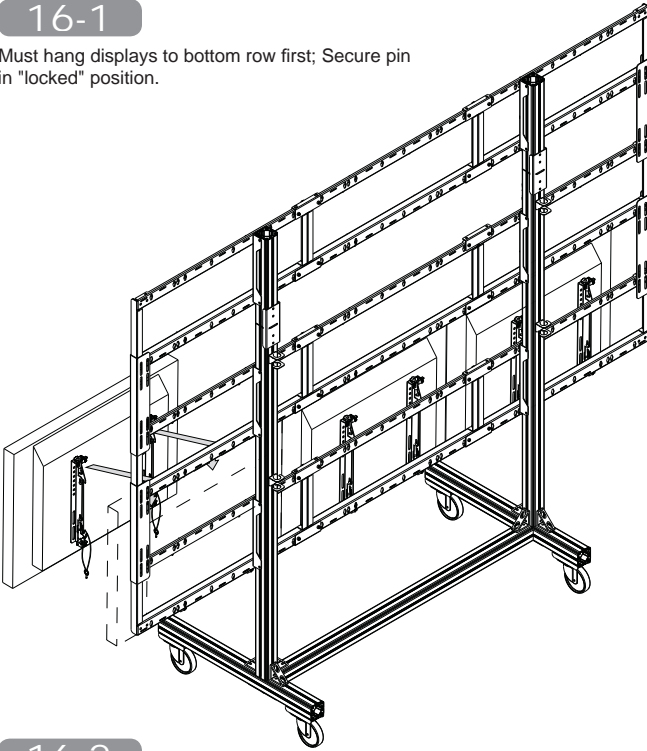

16-2

Must hang displays to middle row second; Secure pin in "locked" position.

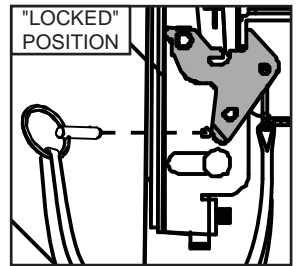
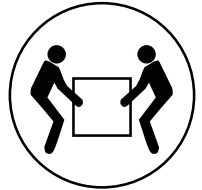
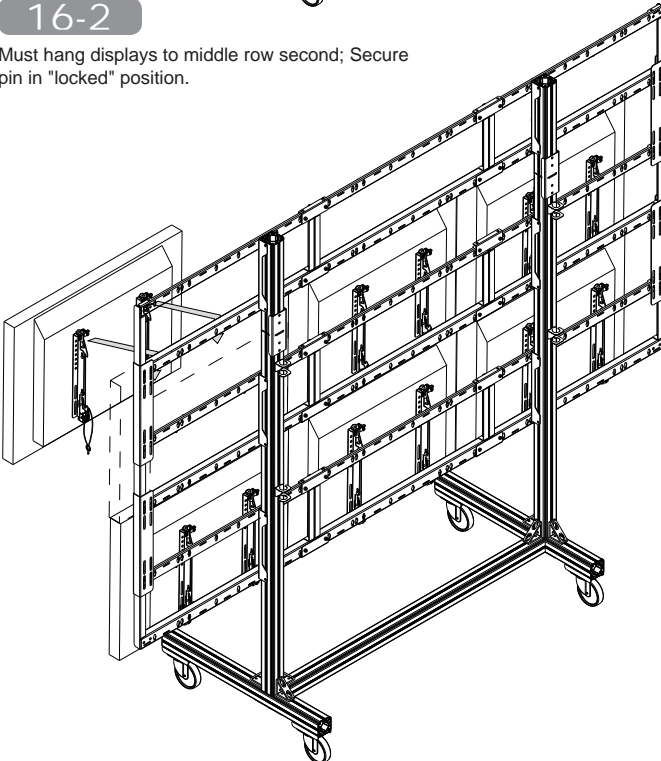

16-3

Must hang displays to top row last; Secure pin in "locked" position.

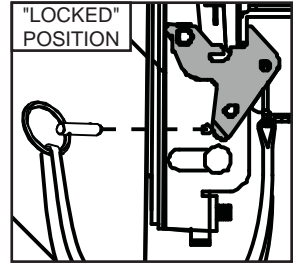
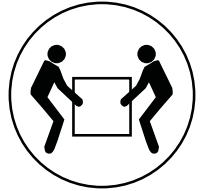
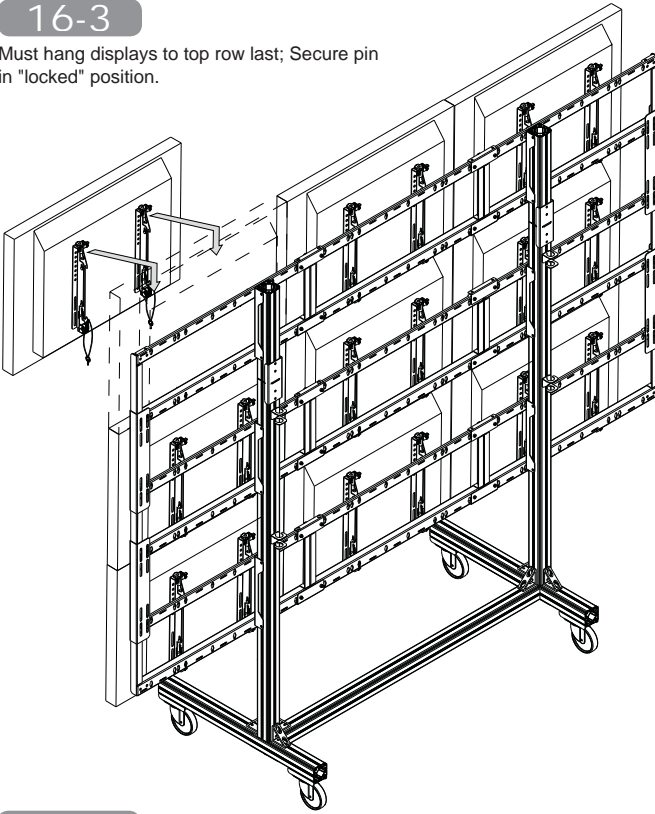

17

OPTIONAL: Insert M5 x 10mm type-F socket pin screws (X) to lock latches.

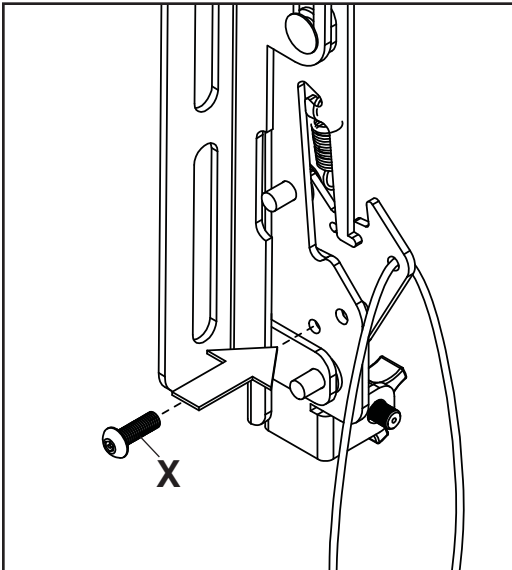
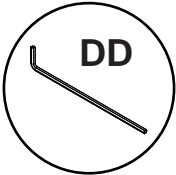

Display Adjustment

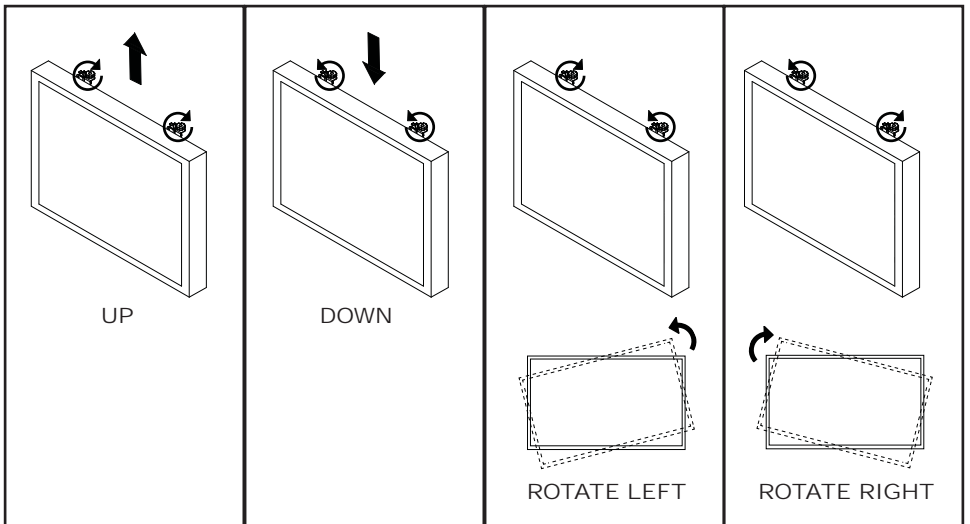
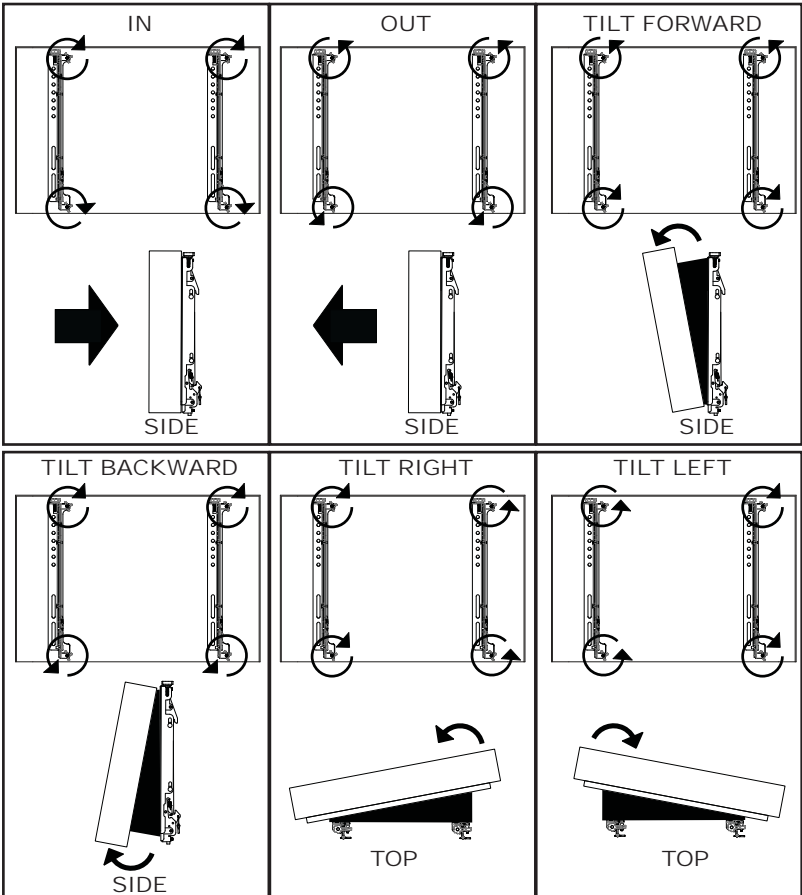

18

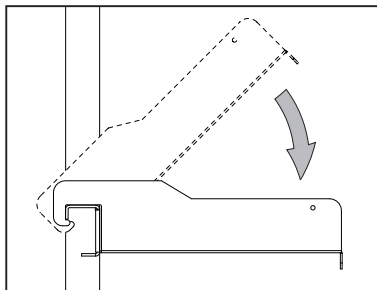
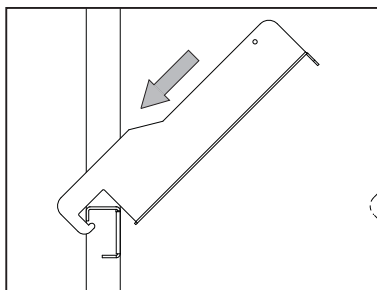
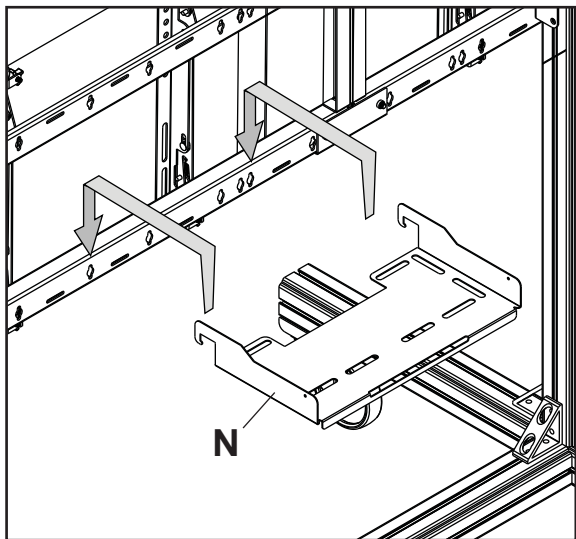

19

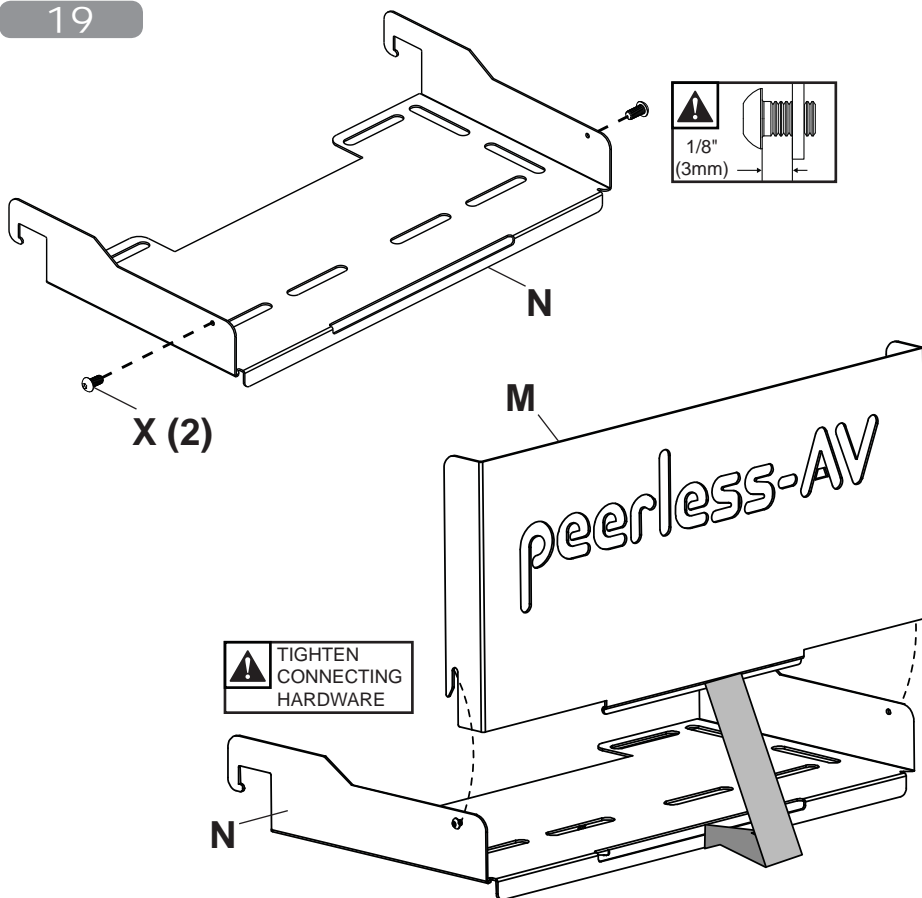

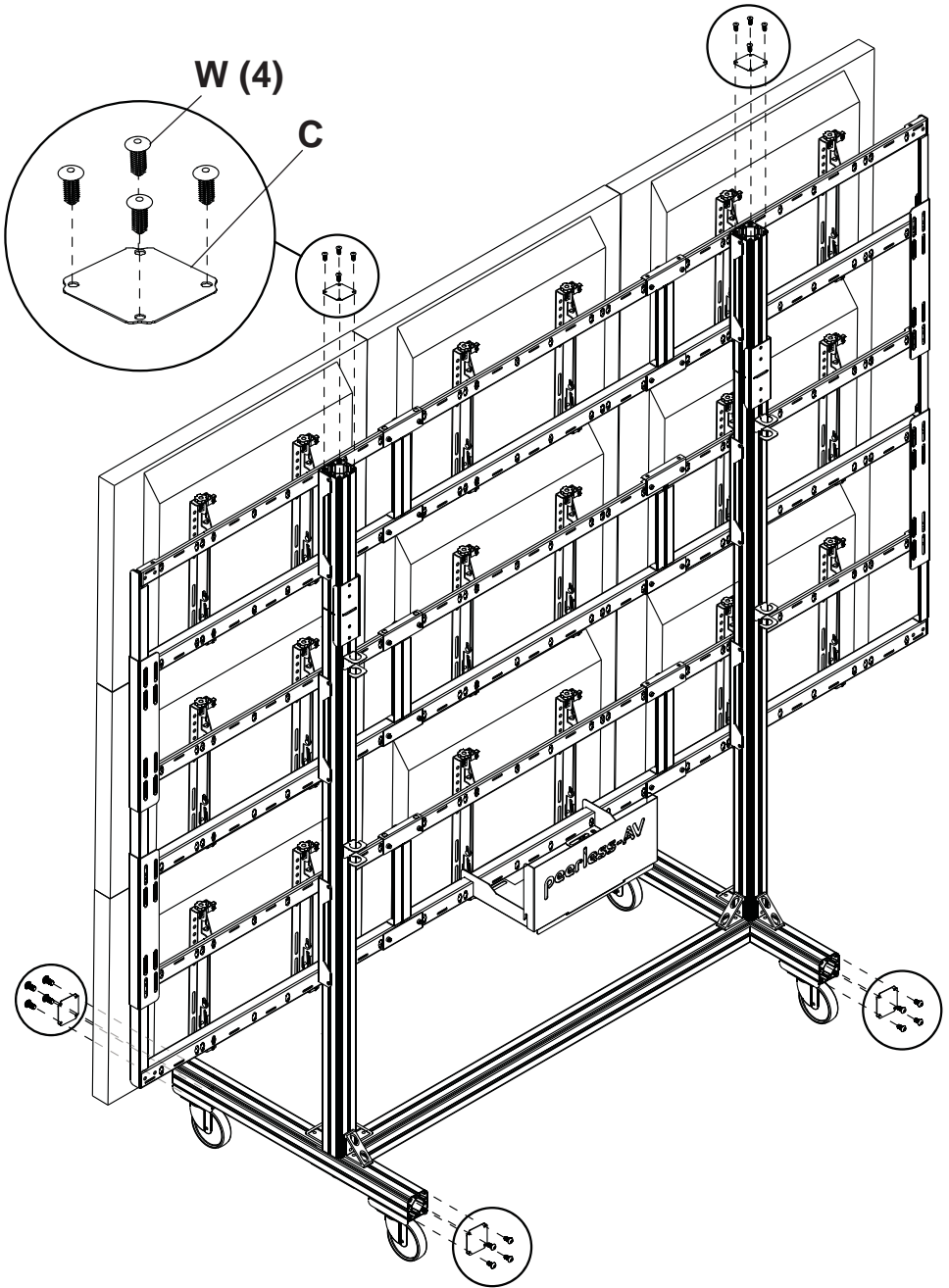

Route cables through cord brackets.

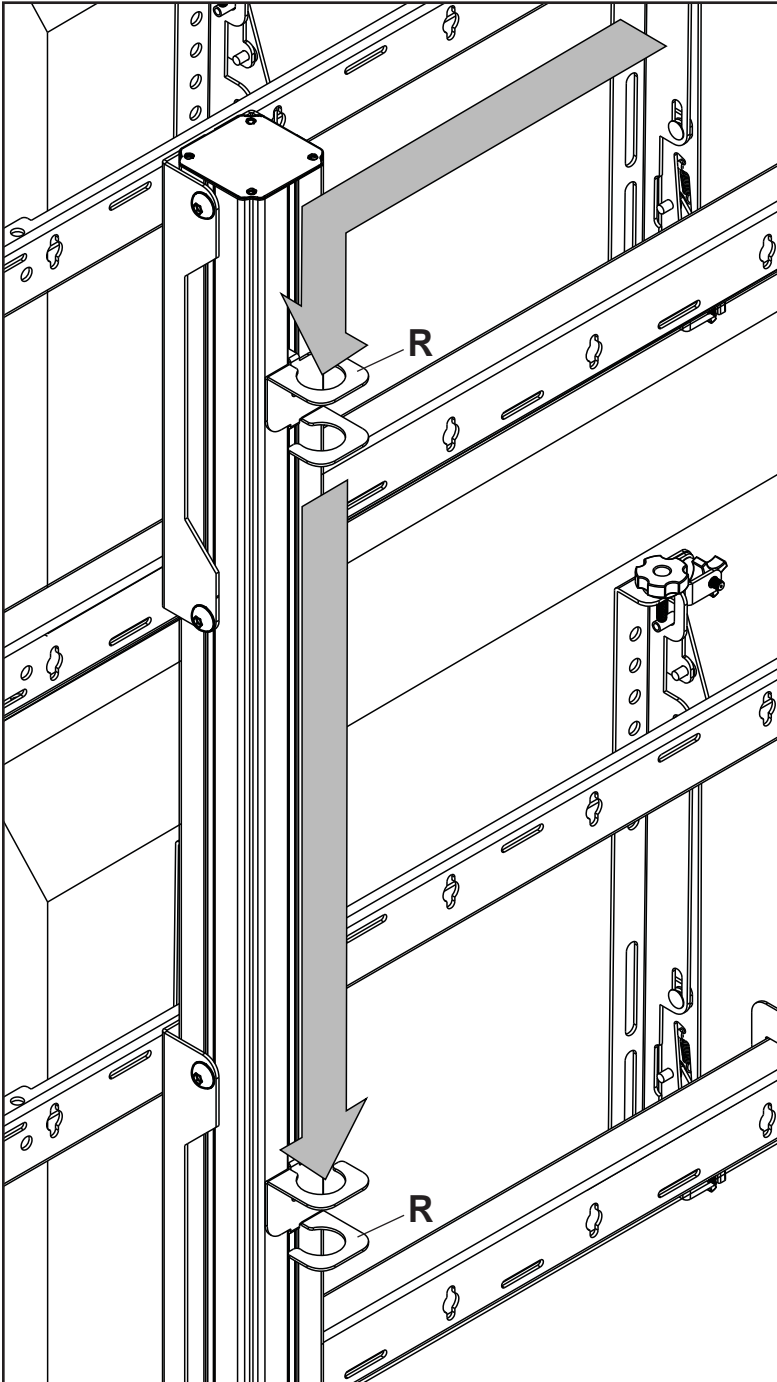

22

Display Removal

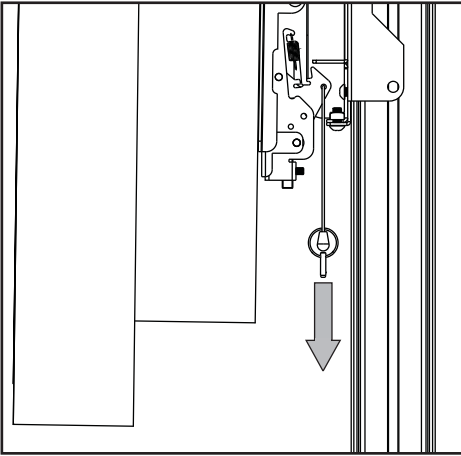

Pull down on bracket cords and hold.

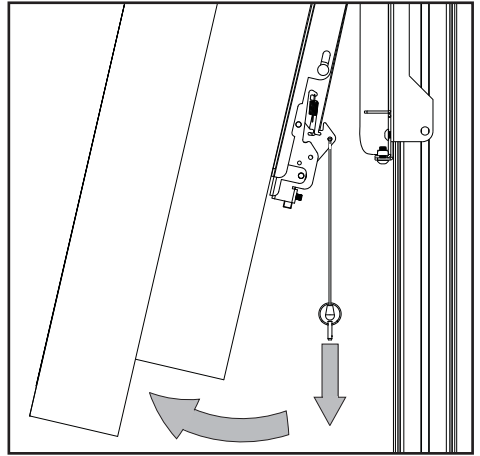

Swing screen away from cart and lift to remove.

23

Remove displays from top row first.

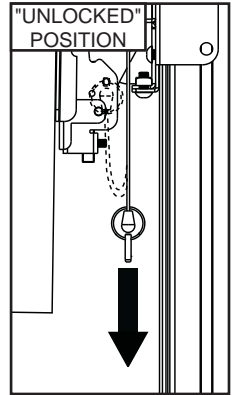
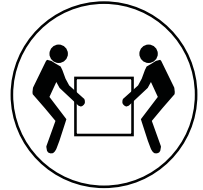
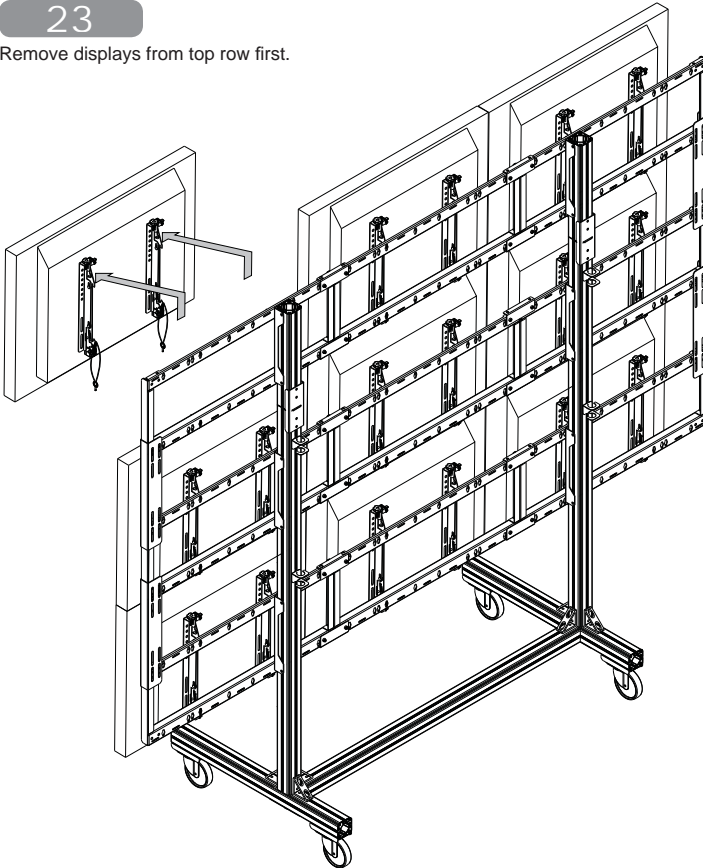

24

Repeat step 22 to remove displays from middle row second.

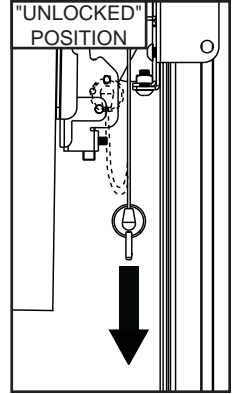
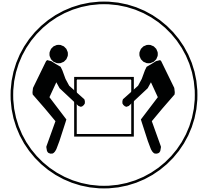
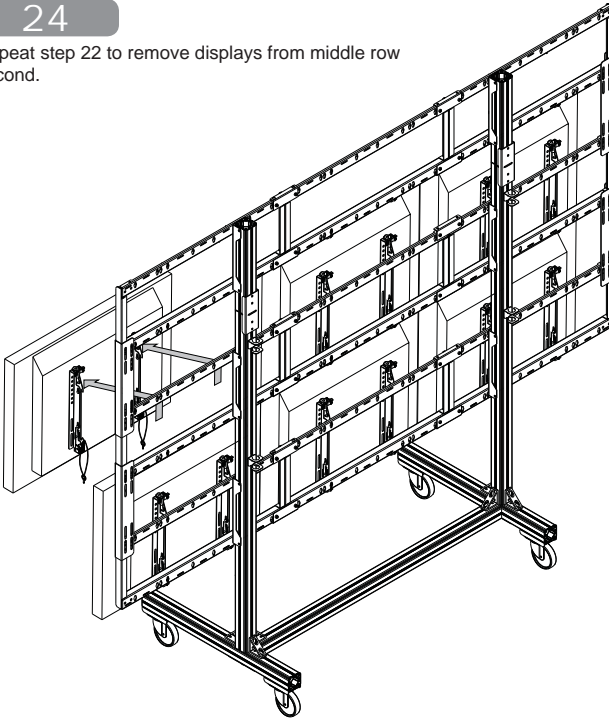

25

Repeat step 22 to remove displays from bottom row last.

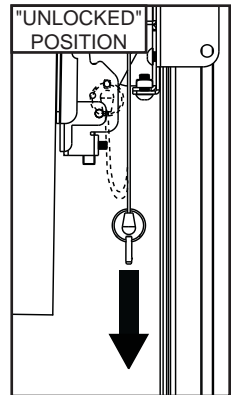
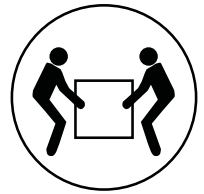
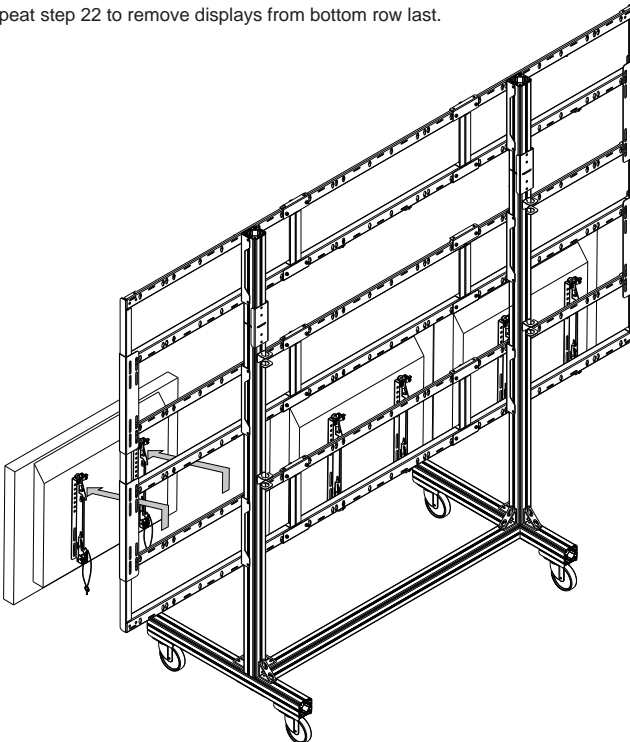

LIMITED FIVE-YEAR WARRANTY

Peerless Industries, Inc. ("Peerless") warrants to original end-users of Peerless® products will be free from defects in material and workmanship, under normal use, for a period of five years from the date of purchase by the original end-user (but in no case longer than six years after the date of the product's manufacture). At its option, Peerless will repair or replace, or refund the purchase price of, any product which fails to conform with this warranty.

In no event shall the duration of any implied warranty of merchantability or fitness for a particular purpose be longer than the period of the applicable express warranty set forth above. Some states do not allow limitations on how long a implied warranty lasts, so the above limitation may not apply to you.

This warranty does not cover damage caused by (a) service or repairs by the customer or a person who is not authorized for such service or repairs by Peerless, (b) the failure to utilize proper packing when returning the product, (c) incorrect installation or the failure to follow Peerless' instructions or warnings when installing, using or storing the product, or (d) misuse or accident, in transit or otherwise, including in cases of third party actions and force majeure.

In no event shall Peerless be liable for incidental or consequential damages or damages arising from the theft of any product, whether or not secured by a security device which may be included with the Peerless® product. Some states do not allow the exclusion or limitation of incidental or consequential damages, so the above limitation or exclusion may not apply to you.

This warranty is in lieu of all other warranties, expressed or implied, and is the sole remedy with respect to product defects. No dealer, distributor, installer or other person is authorized to modify or extend this Limited Warranty or impose any obligation on Peerless in connection with the sale of any Peerless® product.

This warranty gives specific legal rights, and you may also have other rights which vary from state to state.

Touchboards

205 Westwood Ave, Long Branch, NJ 07740

Phone: 866-94 BOARDS (26273) / (732)-222-1511

Fax: (732)-222-7088 | E-mail: sales@touchboards.com

peerless-AV®

Peerless-AV

2300 White Oak Street
Aurora, IL 60502

Email: tech@peerlessmounts.com

Ph: (800) 865-2112

Fax: (800) 359-6500

www.peerless-av.com

© 2014, Peerless Industries, Inc.

Peerless-AV Europe

Unit 3 Watford Interchange,
Colonial Way, Watford, Herts,
WD24 4WP, United Kingdom

Customer Care

44 (0) 1923 200 100

www.peerless-av.com

© 2014, Peerless Industries, Inc.

Peerless-AV de Mexico

Ave de las Industrias 413
Parque Industrial Escobedo
Escobedo N.L Mexico 66050

Servicio al Cliente

01-800-849-65-77

www.peerless-av.com

© 2014, Peerless Industries, Inc.