

DS-C555-4X2



Display size
46"-55"



Max load
800lb (363kg)
100lb per display

SMARTMOUNT.

Portable Video Wall Cart 2x2, 3x2 or 4x2 Configuration

FOR 46" TO 55" DISPLAYS

Peerless-AV takes video wall carts to a new level of innovation. With this new modular design, a 2x2, 3x2, or a 4x2 video wall cart configuration can be built with just a single SKU. This Modular Video Wall Cart offers an 8-point micro-adjustment to create a seamless alignment without the need of tools. With a five-inch lockable caster, the cart becomes secure for safe and easy movement over various flooring surfaces. Designed for a quick set-up and tear down, the cart features a quick-connect latch for adaptors, allowing automatic engagement with mounting rails. Media storage and cable management create a sleek appearance for any application setting. With an overall weight and shipping cost reduction, this Portable Video Wall Cart makes this the ultimate video wall cart solution.

Additional Features

- ✓ Modular design can be utilized for a 2x2, 3x2 or 4x2 configuration with a single SKU
- ✓ Tool-less micro-adjustment at 8 points seamlessly align the displays
- ✓ Lockable 5" casters enable safe and easy maneuverability over various flooring surfaces
- ✓ Cable management through rear adjustable cable centralizing brackets
- ✓ Designed for quick set-up and tear down
- ✓ Adaptors feature a quick connect latch for automatic engagement with the mounting rails and ease of set-up
- ✓ Rear media storage shelf and cover stores components while maintaining a clean appearance
- ✓ Aluminum frame reduces the overall weight and shipping costs
- ✓ VESA® 200 x 200 up to 600 x 400mm compatible

DS-C555-4X2's tool-less micro-adjustment at 8 points helps seamlessly align the displays, creating the ultimate video wall cart solution.



■ **QUICK SET UP AND TEAR DOWN**
Engineered to reduce installation time and cost

■ **MEDIA STORAGE**
Rear shelf provides a central location and clean appearance

■ **NO TOOLS REQUIRED FOR MICRO-ADJUSTMENT**
Simple, tool-less micro-adjustments at 8 points seamlessly align the displays



Touchboards

205 Westwood Ave, Long Branch, NJ 07740
Phone: 866-94 BOARDS (26273) / (732)-222-1511
Fax: (732)-222-7088 | E-mail: sales@touchboards.com



info@peerless-av.com
peerless-av.com

peerless-AV®

DS-C555-4X2 SmartMount® Portable Video Wall Cart 2x2, 3x2 or 4x2 Configuration for 46" to 55" Displays

Product Specifications

	DIMENSIONS (W x H x D)	PRODUCT WEIGHT	LOAD CAPACITY	FINISH	AVAILABLE COLORS
DS-C555-4X2	171.63" x 76.26" x 36.10" (4359 x 1937 x 917mm)	299lb (135.9kg)	800lb (363kg) 100lb per display	Textured	Black

Package Specifications

	PACKAGE SIZE (W x H x D)	PACKAGE SHIP WEIGHT	PACKAGE UPC CODE	PACKAGE CONTENTS	UNITS IN PACKAGE
DS-C555-4X2	37.50" x 12.50" x 84.00" (953 x 318 x 2134mm)	334lb (151.8kg)	735029301509	Stand, casters, display adaptors and hardware	1

Accessories

- ACC-V800X:** Adaptor accessory for 600 x 400 and 800 x 400mm mounting patterns
- ACC310VWC6:** Video Wall Cart Accessory Feet - 6pk

All dimensions = inch (mm)

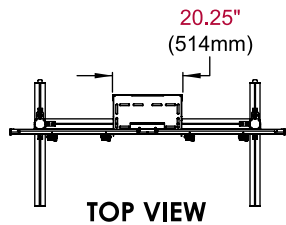

COMPATIBILITY FORMULA
Display height ≤ 36"
Three display widths + mount pattern width ≤ 171"

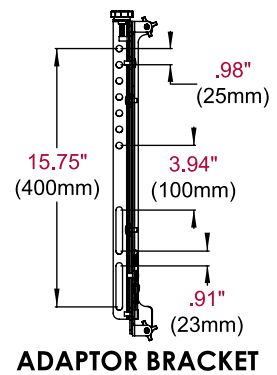
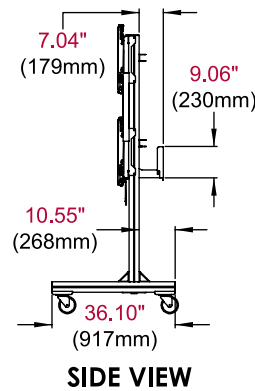
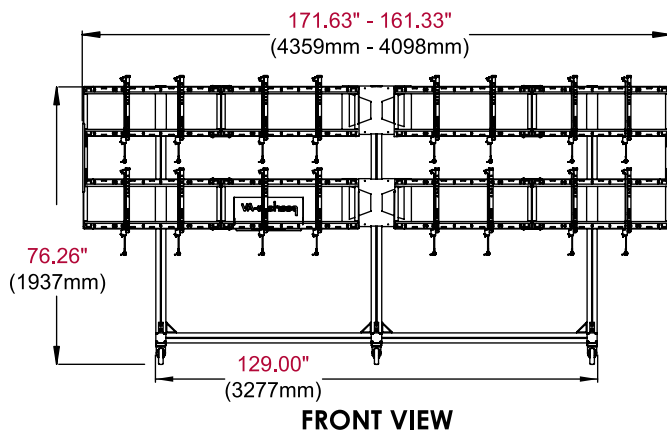

Architect Specifications

The Smartmount® Portable Video Wall Cart 2x2, 3x2 or 4x2 Configuration shall be a Peerless-AV model DS-C555-4X2 and shall be located where indicated on the plans. Assembly and installation shall be done according to instructions provided by the manufacturer.

Visit peerless-av.com to see the complete line of AV solutions from Peerless-AV, including outdoor displays, wireless, kiosks, digital audio, display mounts, projector mounts, carts/stands, and a full assortment of accessories.

Peerless-AV
2300 White Oak Circle
Aurora, IL 60502 USA
(800) 865-2112
(630) 375-5100
Fax: (800) 359-6500

Peerless-AV Europe
Unit 3 Watford Interchange
Colonial Way, Watford
Herts, WD24 4WP
United Kingdom
+44 (0) 1923 200100
Fax: +44 (0) 1923 200101

Peerless-AV de México
Ave de las Industrias 413
Parque Industrial Escobedo
Escobedo, N.L.,
Mexico 66050
+52 (81) 8384-8300
Fax: +52 (81) 8384-8360

