

# peerless-AV<sup>®</sup>

## DS-S560-2X2



46" - 55"  
(117 - 140 cm)



500 lb  
(227 kg)

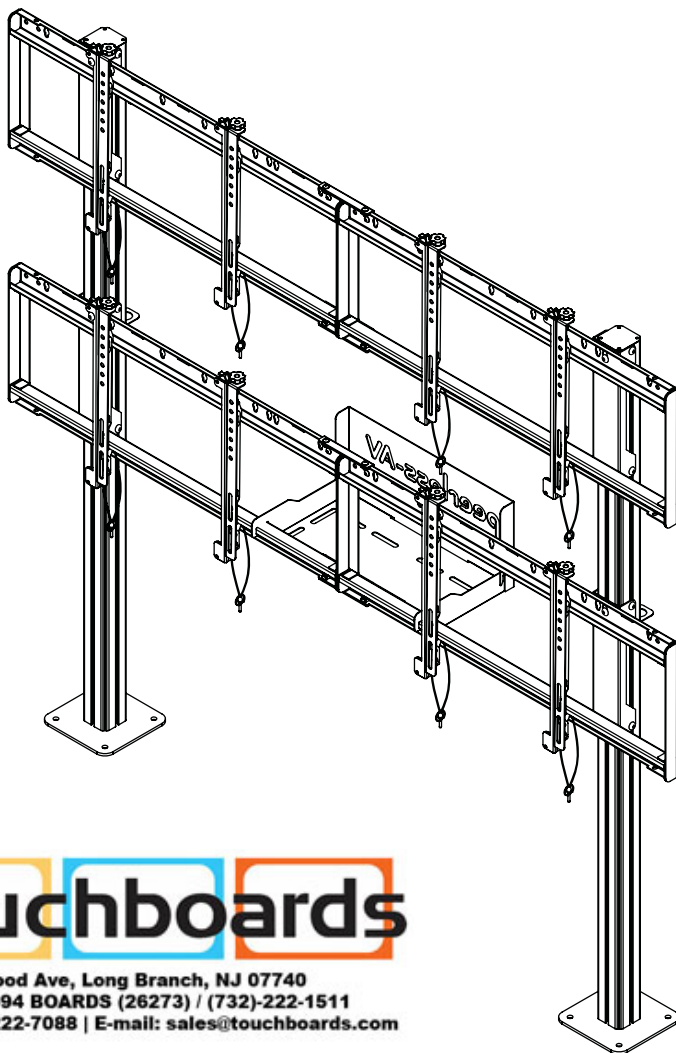

# Touchboards

205 Westwood Ave, Long Branch, NJ 07740  
Phone: 866-94 BOARDS (26273) / (732)-222-1511  
Fax: (732)-222-7088 | E-mail: [sales@touchboards.com](mailto:sales@touchboards.com)



# ▲ WARNING

ENG - This product is designed to be installed on solid concrete. Hardware is included for solid concrete installation. Before installing make sure the supporting surface will support the combined load of the equipment and hardware. Screws must be tightly secured. Do not overtighten screws or damage can occur and product may fail. Never exceed the Maximum Load Capacity. Always use an assistant or mechanical lifting equipment to safely lift and position equipment. This product is intended for indoor use only. Use of this product outdoors could lead to product failure or personal injury. Be careful not to pinch fingers when operating the mount. For support please call customer care at 1-800-865-2112.

## ENG Symbols



ENG WARNING

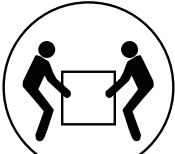

Heavy



ENG Display center.



ENG Screws must get at least three full turns and fit snug.



To properly tighten screws: Tighten until screw head makes contact, then tighten another 1/2 turn. Do not overtighten screws.

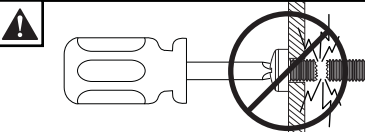
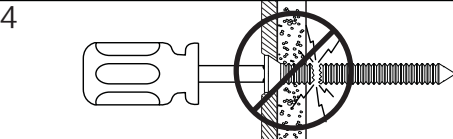
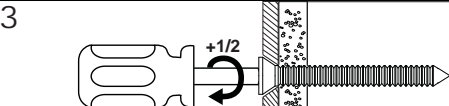
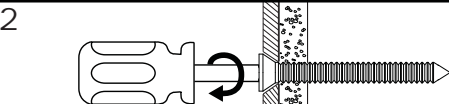
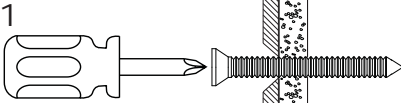

ENG Do not overtighten screws.

## ENG Tools Needed for Assembly.

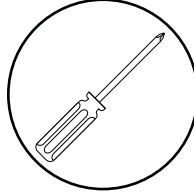
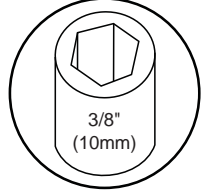
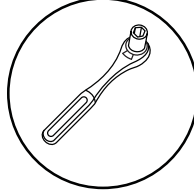
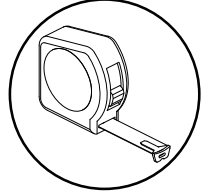
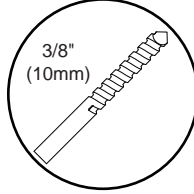
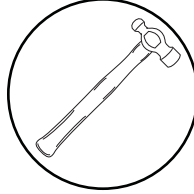
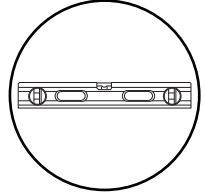
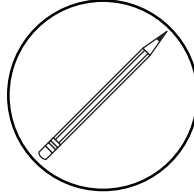

Parts (Before beginning, make sure you have all parts shown below).

<b>Parts List</b>		
Description	Qty	Part #
<b>A</b> pedestal	2	146-T1132
<b>B</b> column	2	146-T1131
<b>C</b> cover	2	145-T1809
<b>D</b> adaptor bracket	8	145-T1792
<b>E</b> vertical support bracket	4	145-T1806
<b>F</b> computer cover	1	145-T1930
<b>G</b> computer shelf	1	145-T1931
<b>H</b> dual cross support	2	145-T1924
<b>I</b> locking tab	4	145-T1936
<b>J</b> cord bracket	4	145-T1929
<b>K</b> M8 x 16mm socket button screw	40	520-9527
<b>L</b> M8 square nut	16	530-1066
<b>M</b> cover clip	8	590-0317
<b>N</b> M5 x 10mm type-f, socket pin screw	10	520-1164
<b>O</b> M5 x 12mm socket pin screw	4	520-1064
<b>P</b> 1/4" power bit	1	560-0263
<b>Q</b> 5mm allen wrench	1	560-9640
<b>R</b> nylon shoulder washer	16	590-2233
<b>S</b> M6 x 12mm socket pin screw	16	520-1050
<b>T</b> 4mm allen wrench	1	560-9646
<b>U</b> M6 x 35mm screw	8	520-0717
<b>V</b> rawl bolt #6913	8	5M9-381-H03

**A (2)**

pedestal

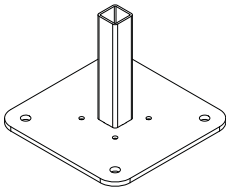

**C (2)**

cover

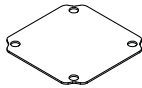

**D (8)**

adaptor bracket

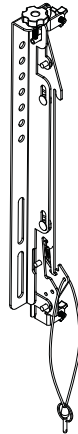

**E (4)**

vertical support bracket



**B (2)**

column

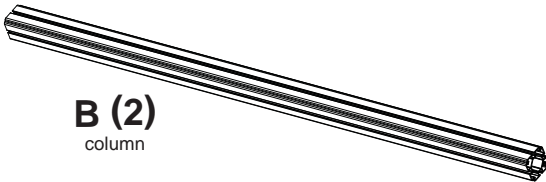

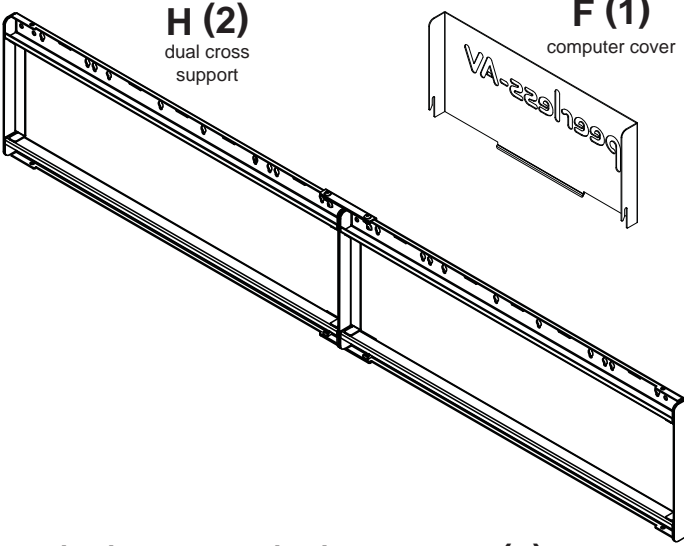

**H (2)**

dual cross support

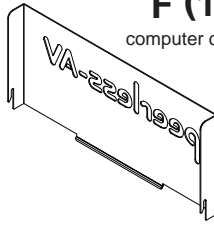

**F (1)**

computer cover

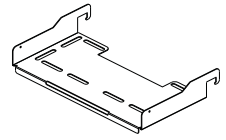

**G (1)**

computer shelf

**I (4)**  
locking tab

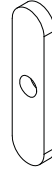

**J (4)**  
cord bracket



**K (40)**  
M8 x 16mm

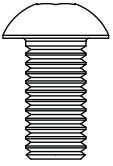

**L (16)**  
M8 square nut

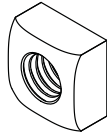

**M (8)**  
cover clip

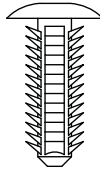

**N (10)**  
M5 x 10mm

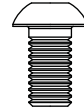

**O (4)**  
M5 x 12mm

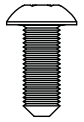

**P (1)**  
1/4" power bit

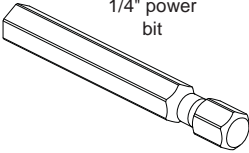

**Q (1)**  
5mm allen wrench

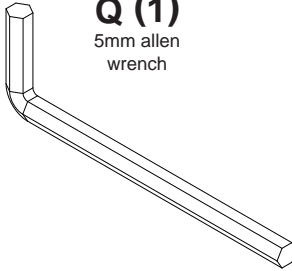

**R (16)**  
nylon shoulder washer

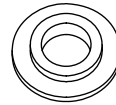

**S (16)**  
M6 x 12mm

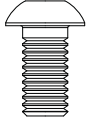

**U (8)**  
M6 x 35mm



**T (1)**  
4mm allen wrench

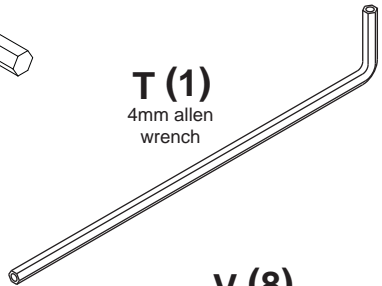

**V (8)**  
rawl bolt

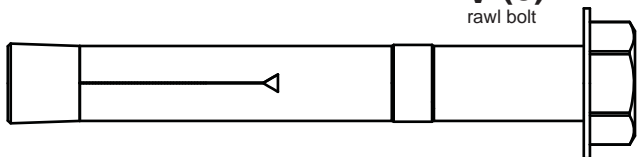

1

x2

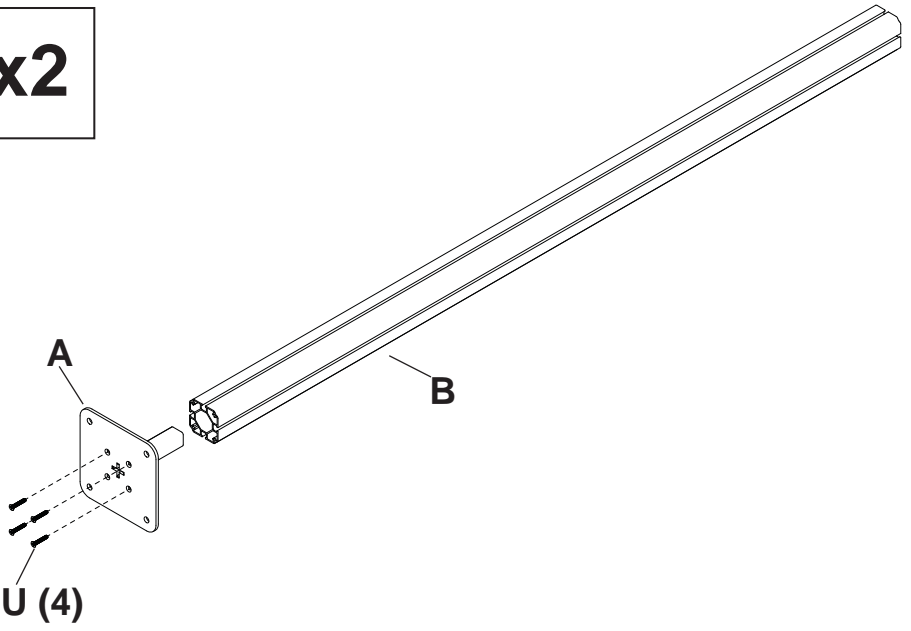

**ENG** Repeat for each vertical support bracket (x4).

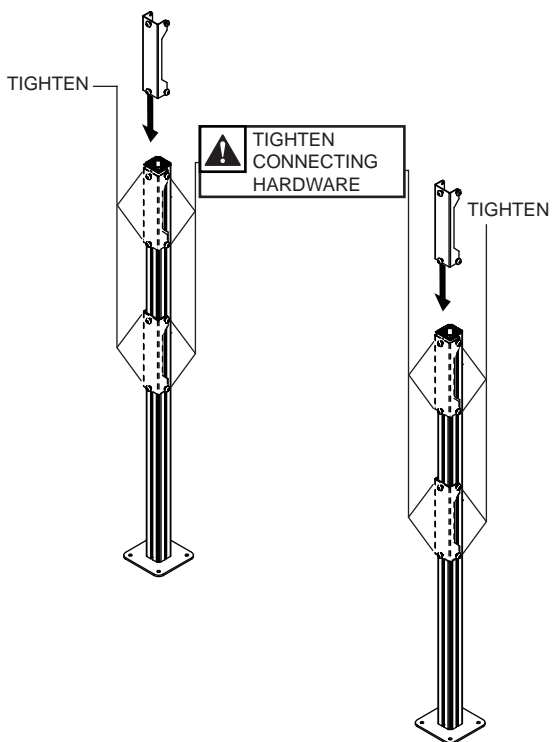
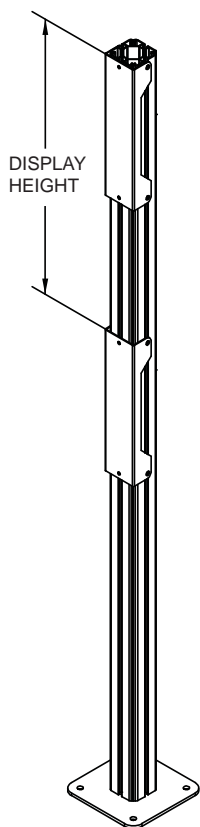
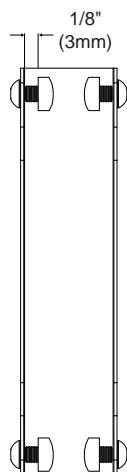
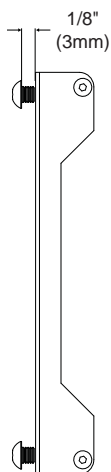
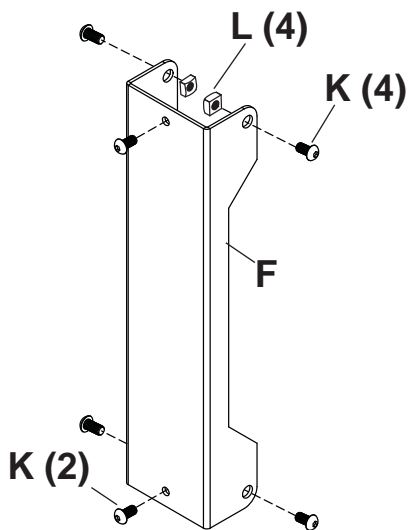

3-1

x2

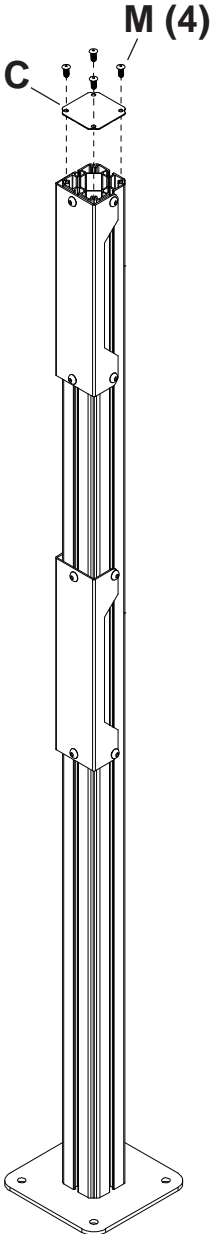

3-2

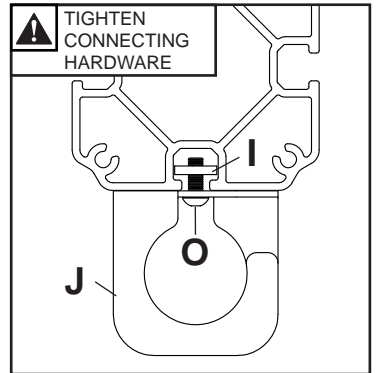
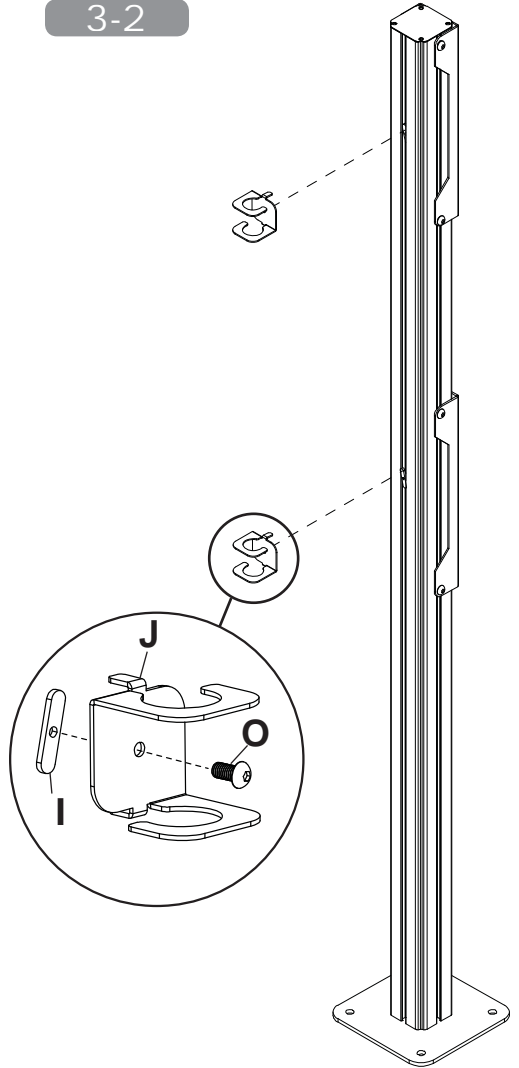

TOP VIEW

## 4-1

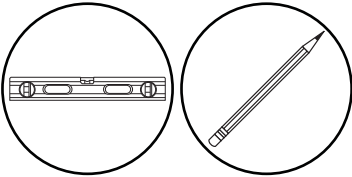

**ENG** Align base. Mark mounting holes.

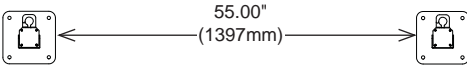
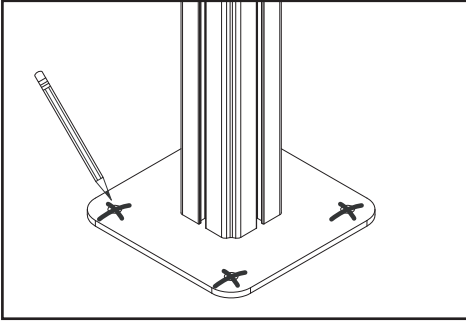

## 4-2

**ENG** Drill mounting holes into supporting surface (3" (76 mm) minimum depth required).

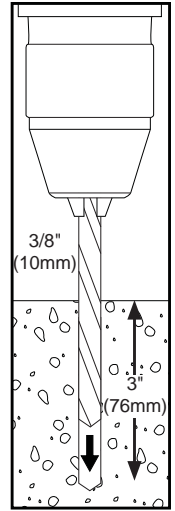
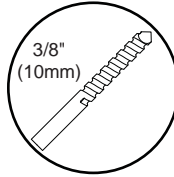

## 4-3

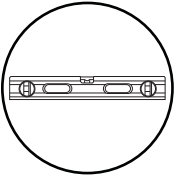
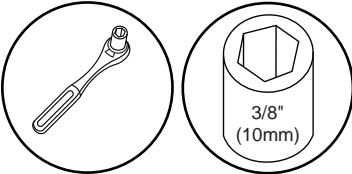

**ENG** Align base. Install using concrete anchors provided.

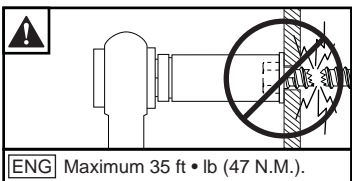

**ENG** Maximum 35 ft • lb (47 N.M.).

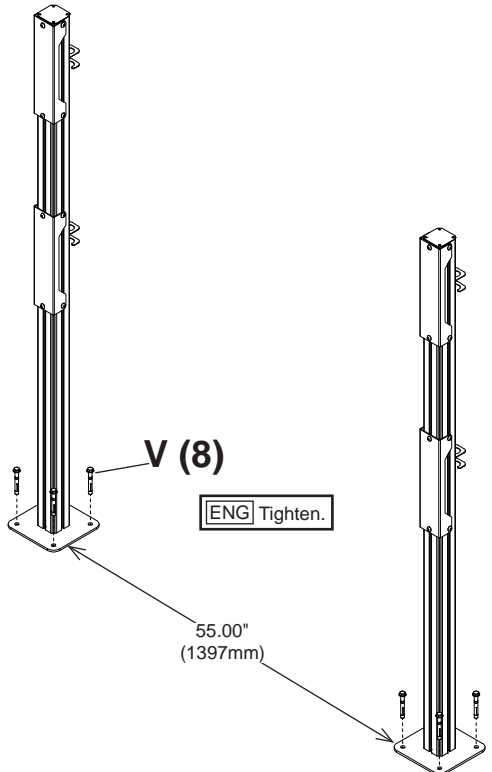



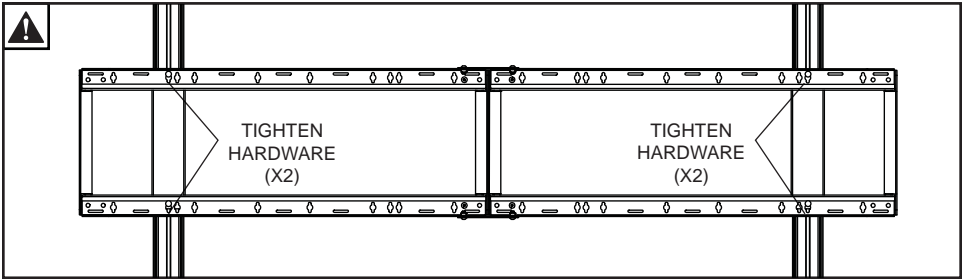
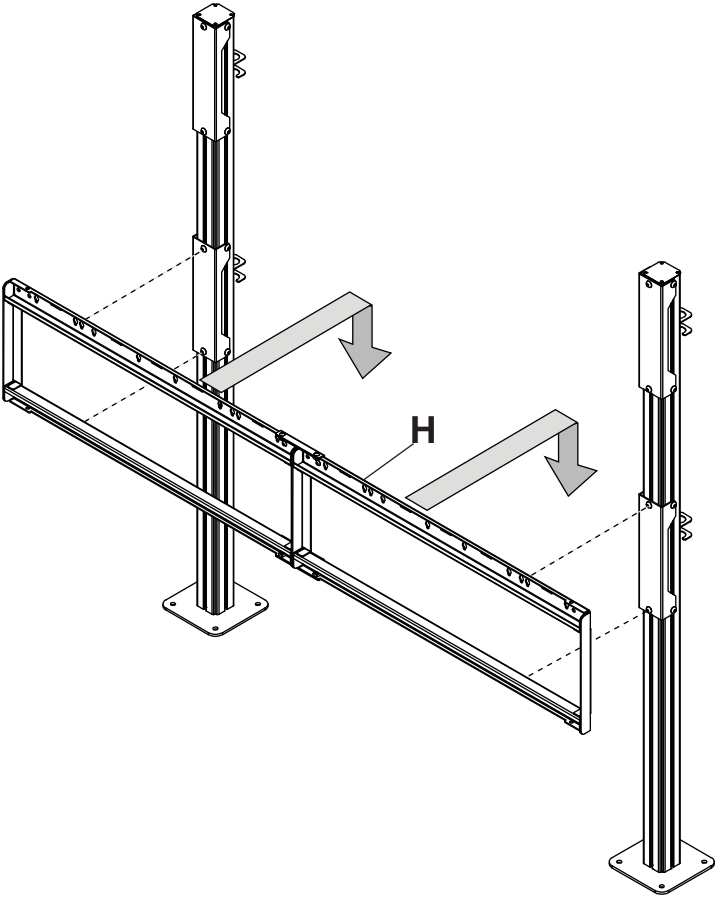
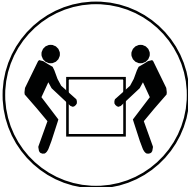

ENG Cross supports must center on columns.

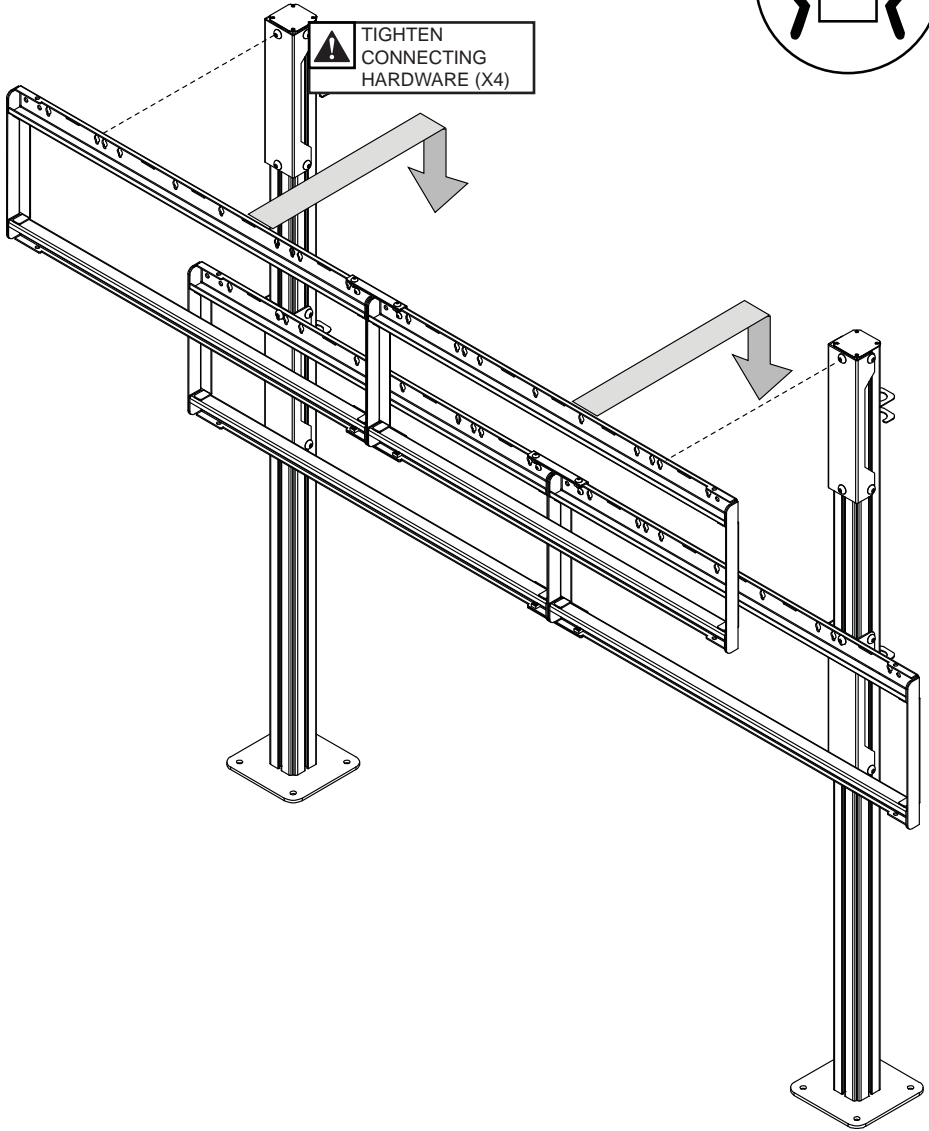
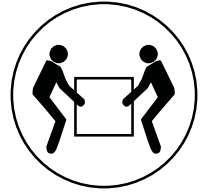

# 6

ENG Center adaptor brackets vertically on back of screen.

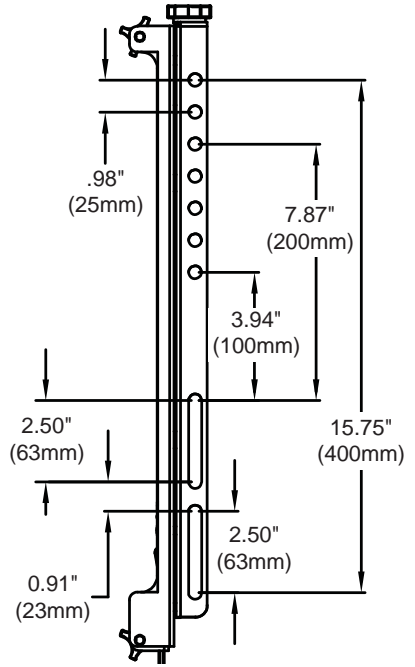
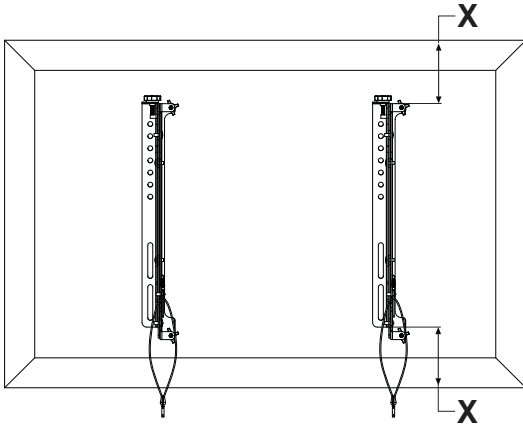

# 6-1

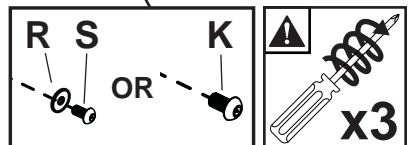
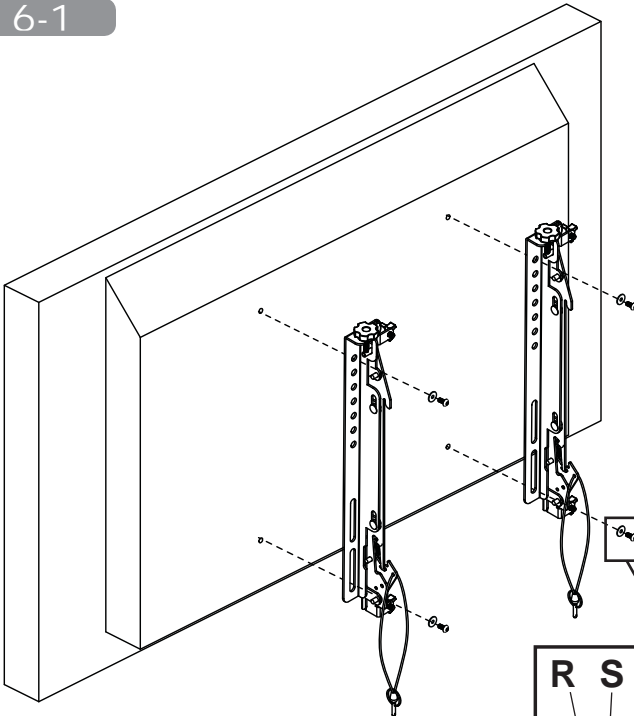

## 7-1

**ENG** Hook on displays and secure pin in "locked" position.

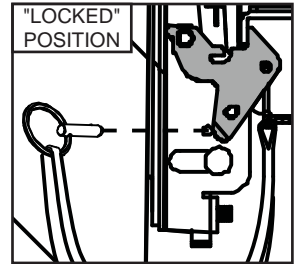
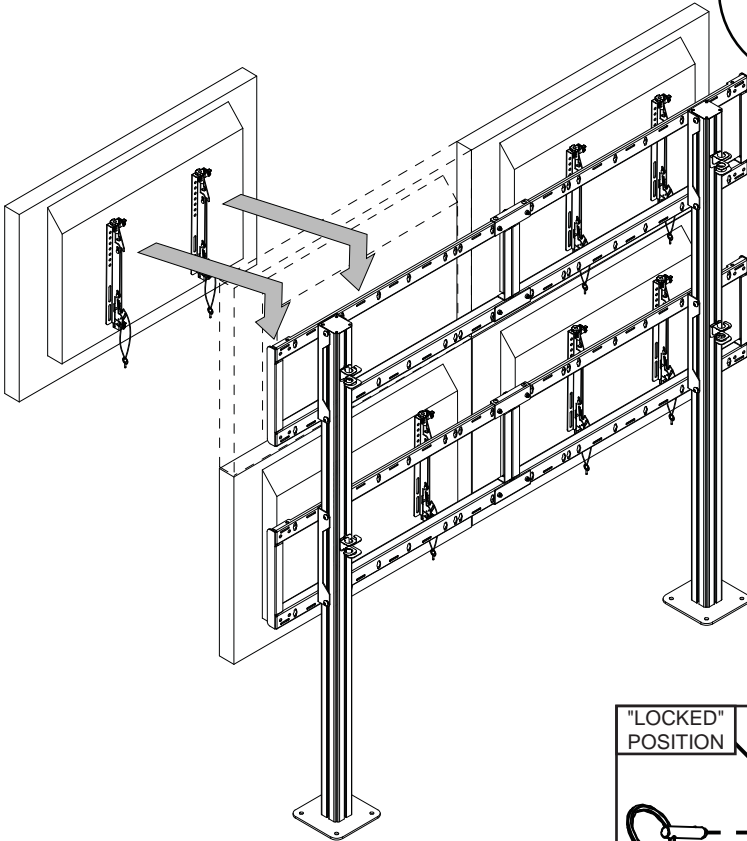

## 7-2

**ENG** OPTIONAL: Insert M5 x 10mm type-F socket pin screws to lock latches.

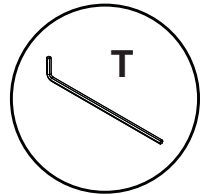
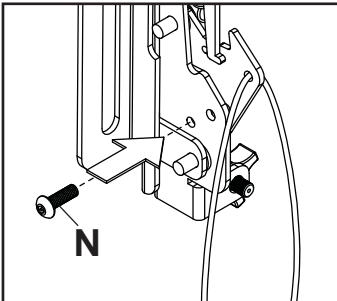

# Display Adjustment

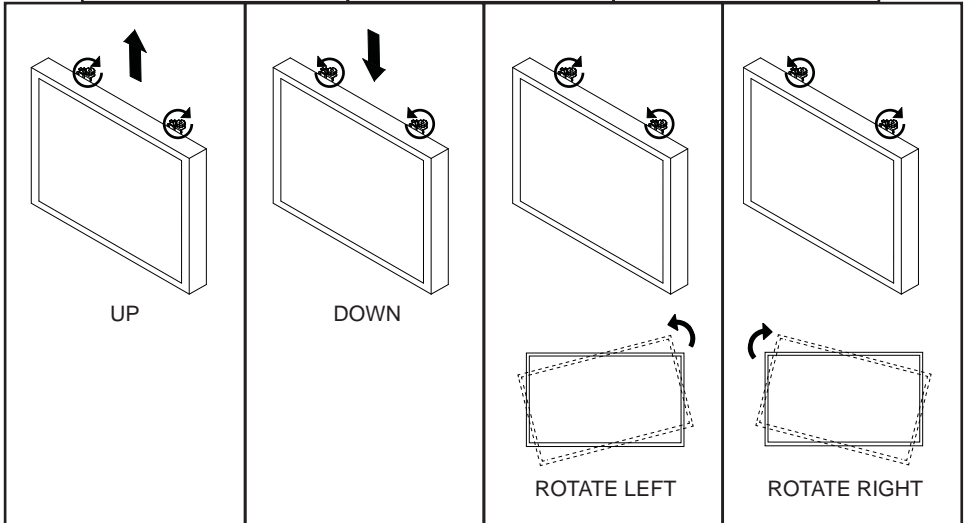
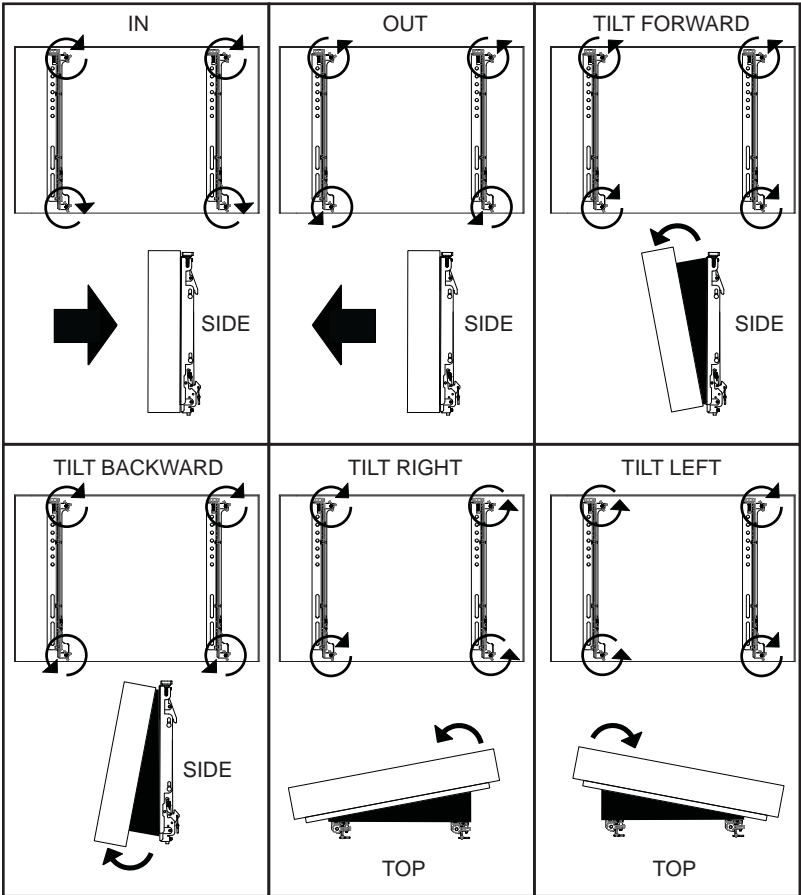

8

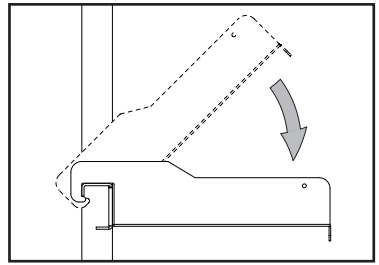
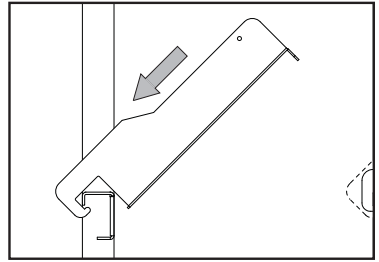
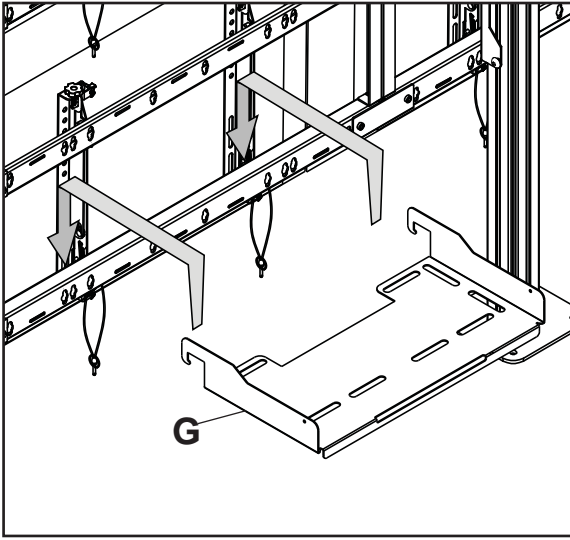

9

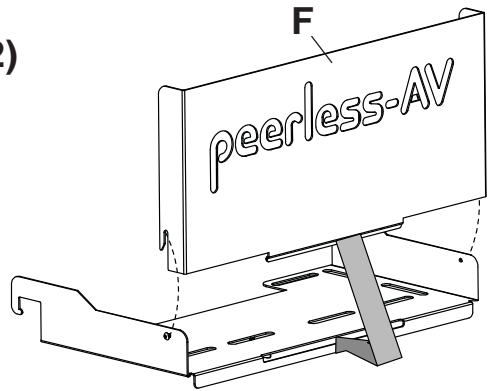
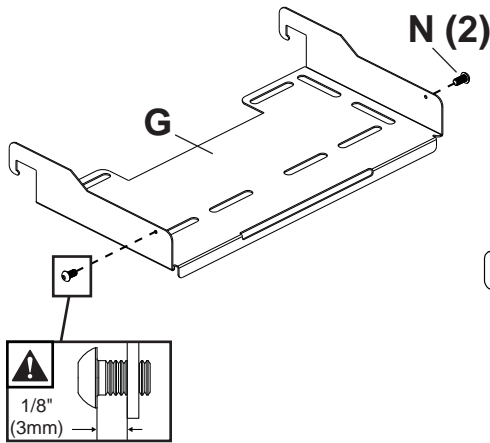

 TIGHTEN  
CONNECTING  
HARDWARE

ENG Route cables through cord brackets.

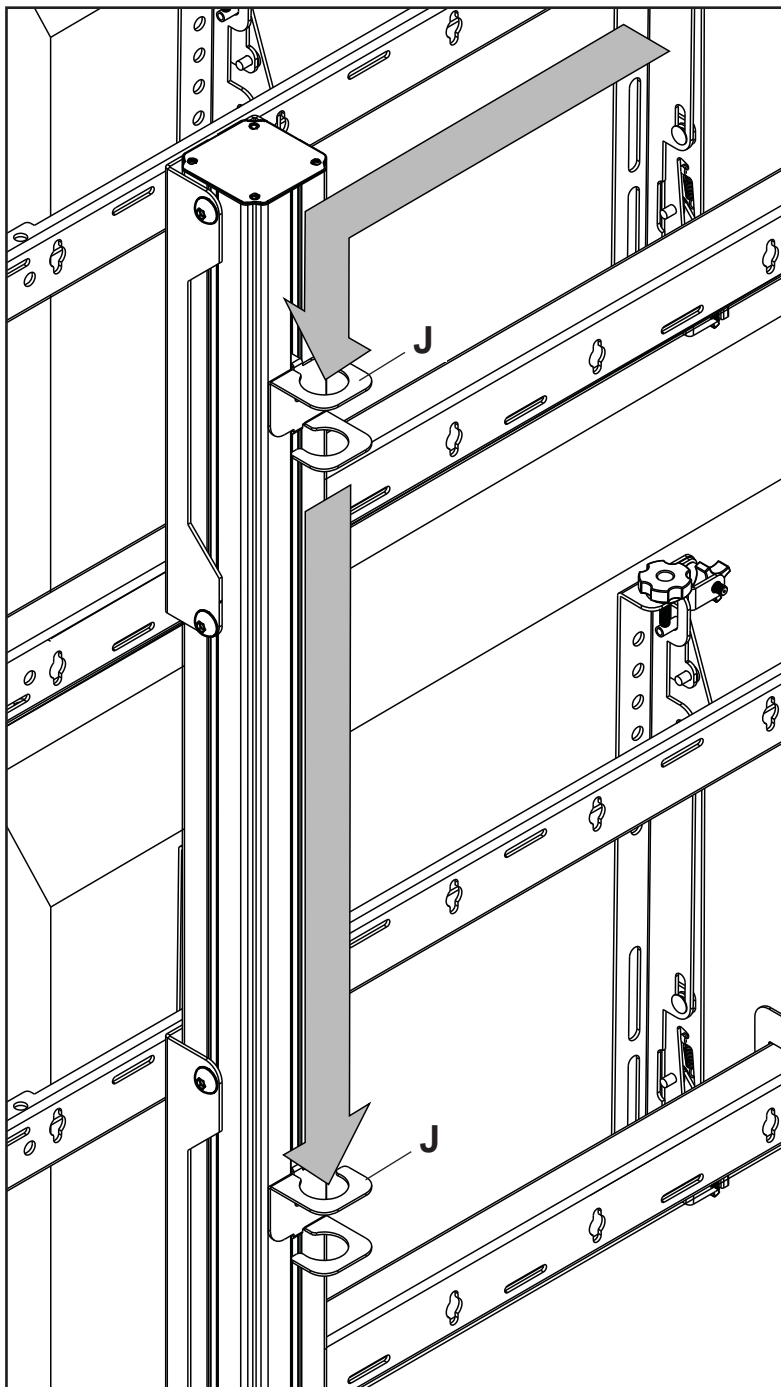

## LIMITED FIVE-YEAR WARRANTY

Peerless Industries, Inc. ("Peerless") warrants to original end-users of Peerless® products will be free from defects in material and workmanship, under normal use, for a period of five years from the date of purchase by the original end-user (but in no case longer than six years after the date of the product's manufacture). At its option, Peerless will repair or replace, or refund the purchase price of, any product which fails to conform with this warranty.

**In no event shall the duration of any implied warranty of merchantability or fitness for a particular purpose be longer than the period of the applicable express warranty set forth above.** Some states do not allow limitations on how long a implied warranty lasts, so the above limitation may not apply to you.

This warranty does not cover damage caused by (a) service or repairs by the customer or a person who is not authorized for such service or repairs by Peerless, (b) the failure to utilize proper packing when returning the product, (c) incorrect installation or the failure to follow Peerless' instructions or warnings when installing, using or storing the product, or (d) misuse or accident, in transit or otherwise, including in cases of third party actions and force majeure.

**In no event shall Peerless be liable for incidental or consequential damages or damages arising from the theft of any product, whether or not secured by a security device which may be included with the Peerless® product.** Some states do not allow the exclusion or limitation of incidental or consequential damages, so the above limitation or exclusion may not apply to you.

This warranty is in lieu of all other warranties, expressed or implied, and is the sole remedy with respect to product defects. No dealer, distributor, installer or other person is authorized to modify or extend this Limited Warranty or impose any obligation on Peerless in connection with the sale of any Peerless® product.

This warranty gives specific legal rights, and you may also have other rights which vary from state to state.



205 Westwood Ave, Long Branch, NJ 07740

Phone: 866-94 BOARDS (26273) / (732)-222-1511

Fax: (732)-222-7088 | E-mail: [sales@touchboards.com](mailto:sales@touchboards.com)

# peerless-AV®

#### Peerless-AV

2300 White Oak Circle  
Aurora, IL 60502

Email: [tech@peerlessmounts.com](mailto:tech@peerlessmounts.com)

Ph: (800) 865-2112

Fax: (800) 359-6500

[www.peerless-av.com](http://www.peerless-av.com)

© 2014, Peerless Industries, Inc.

#### Peerless-AV Europe

Unit 3 Watford Interchange,  
Colonial Way, Watford, Herts,  
WD24 4WP, United Kingdom  
Customer Care

44 (0) 1923 200 100

[www.peerless-av.com](http://www.peerless-av.com)

© 2014, Peerless Industries, Inc.

#### Peerless-AV de Mexico

Ave de las Industrias 413  
Parque Industrial Escobedo  
Escobedo N.L Mexico 66050  
Servicio al Cliente

01-800-849-65-77

[www.peerless-av.com](http://www.peerless-av.com)

© 2014, Peerless Industries, Inc.