

## SERIES SAH | DWYER SMART AIR HOOD™ BALANCING INSTRUMENT



### FEATURES/BENEFITS

- **QUAD FLOW DESIGN TECHNOLOGY**

A patent pending design based on controlling the circulating air patterns providing a more even air flow with minimal backpressure effects. The design results in an accuracy of 3% or better regardless of diffuser types, based on any diffuser in the Dwyer PredictAir™ application software.

- **PREDICTIVE BALANCING**

An industry first for airflow balancing, this patent pending process guides the balancing technician on setting the proper air flow values for each diffuser to fully optimize the HVAC system. No more guess work as Predictive Balancing provides the optimal flow set point for each sequential terminal. The PredictAir™ application software completes the balancing process in much less time than traditional balancing methods.

- **ERGONOMIC DESIGN**

Made from a rugged lightweight polymer construction; it is the smallest, lightest and most aerodynamic design in the industry, weighing less than 6 pounds and 1/4 the height of other bulky air hoods. The Series SAH mounts to an extendable pole for easy use and maneuverability resulting in less muscle strain compared to other air balancing equipment. Balancing can be completed by just one technician.

- **MOBILE SPEED**

With the digital handheld test instrument and software, featuring Wi-Fi direct wireless communications and a range of up to 200 yards (183 m), the testing, adjusting and balancing process is faster and more accurate than any other air flow hood on the market today.

- **LOWEST TOTAL COST OF OWNERSHIP**

Fast, accurate and easy; a better way to air balance saving time and money. The Series SAH features a rechargeable lithium battery backed up by four AA batteries. For annual calibration, simply detach the removable quad flow sensing grids and sensor module and return without the hood for calibration. To ensure no downtime, simply snap on another calibrated set quad flow sensing grids and sensor module.

### APPLICATIONS

- Measuring volumetric air flow from diffusers, grilles and registers in HVAC systems for commercial buildings.

### DESCRIPTION

The **SERIES SAH SMART Air Hood™** Balancing Instrument is a revolutionary air flow hood, made with rugged polymer construction that represents the smallest and most aerodynamic design in the industry. The patent pending Quad Flow Design Technology is based on controlling air flow and minimizing back pressure which yields superior measurement accuracy. Featuring Wi-Fi direct communication, with a range of up to 200 yards (183 m) between the hood and a handheld test instrument, the user interface, mobility, data storage and transmission has never been better. The Series SAH includes Predictive Balancing, an industry first for air flow balancing. Predictive Balancing is a method of projecting the optimal flow set point for each diffuser while balancing the HVAC system. The handheld PredictAir™ application software includes algorithms enabling Predictive Balancing to achieve best in class accuracy. Balancing can be done with just one technician.



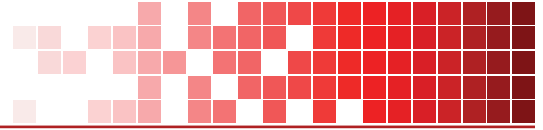

## SPECIFICATIONS

VOLUME FLOW	
Service	Air.
Units	CFM, l/s, m <sup>3</sup> /h.
Range	40 to 2000 CFM (19 to 944 l/s) (68 to 3398 m <sup>3</sup> /h).
Accuracy at Calibration > 40 CFM	±3% of reading ±7 CFM (3.3 l/s) (12 m <sup>3</sup> /h)*.
Accuracy for Any Diffuser > 40 CFM	±3% of reading ±10 CFM (4.7 l/s) (17 m <sup>3</sup> /h)**.
Resolution	1 CFM (.5 l/s) (1.7 m <sup>3</sup> /h).
TEMPERATURE	
Units	°C, °F, K.
Operating Range	40 to 140°F (4 to 60°C).
Storage Range	-4 to 122°F (-20 to 50°C).
Accuracy	±0.3% of reading (no calibration required).
RELATIVE HUMIDITY	
Range	5 to 95%.
Accuracy	±5% of reading (no calibration required).
ABSOLUTE PRESSURE	
Units	mbar, Pa.
Range	10 to 2000 mbar (1000 to 200,000 Pa).
Accuracy @ 25°C and within 300 to 1100 mbar	±2% of reading (no calibration required).
POWER REQUIREMENT	
Battery	3.6 V NCR18650B MH12210 lithium ion battery, included, user replaceable or (4) 1.5 V AA alkaline batteries, not included, user replaceable.
PHYSICAL CHARACTERISTICS	
Weight	5.75 lb (2.6 kg).
Agency Approvals	CE, FCC, IC.
*Based on calibration with Sensing Precision and Dwyer standard diffuser.	
**Based on any diffuser in the Dwyer PredictAir™ application software download library.	

## STANDARD EQUIPMENT

- SAH Base unit, 2 ft x 2 ft (0.61 m x 0.61 m) opening
- Handheld test instrument with attached quick release
- Extendable pole 4.5 ft to 12 ft (1.4 m to 3.7 m) with handheld test instrument connection
- Extendable pole 2 ft to 4 ft (0.61 m to 1.22 m) with handheld test instrument connection
- Pole locking connection
- SAH travel case
- Cable to connect the SAH and the handheld test instrument
- Charger and cable for SAH and handheld test instrument

## DIMENSIONS

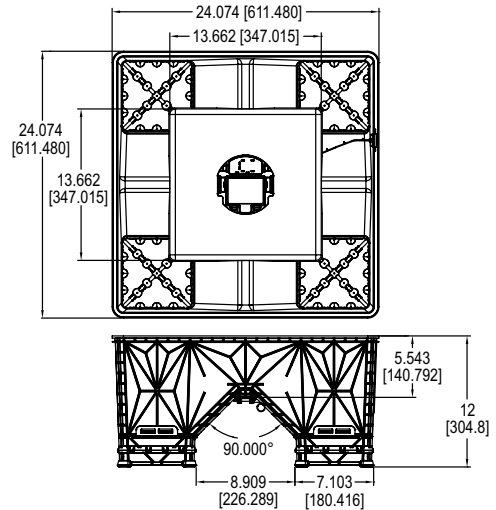

## HOW TO ORDER

Use the **bold** characters from the chart below to construct a product code.

<b>SERIES</b>	<b>SAH</b>	<b>-22</b>	<b>-LB</b>
<b>SAH - SMART Air Hood™</b> Balancing Instrument with Standard Equipment			
<b>SIZE</b>			
<b>-22 - 2' x 2'</b> (0.61 m x 0.61 m) opening			
<b>OPTIONS</b>			
<b>-LB - Less lithium battery</b>			

## ACCESSORIES

Model	Description
<b>A-SAH-14S</b>	Canvas hood 1 ft x 4 ft (0.31 m x 1.22 m)
<b>A-SAH-BK</b>	SAH adapter base kit for canvas hood
<b>A-SAH-CK</b>	Spare calibration kit, quad flow sensing grids and sensor module

Important Notice: Dwyer Instruments, Inc. reserves the right to make changes to or discontinue any product or service identified in this publication without notice. Dwyer advises its customers to obtain the latest version of the relevant information to verify, before placing any orders, that the information being relied upon is current.

