

ITEM NO.	PART NUMBER	DESCRIPTION	QTY.
1	3-13BK01	STANDARD DIGITAL TOUCH LOCK	2
2	42 PCT	REFERENCE PCAP SCREEN	1
3	AEHS8-420-165	1/4-20 HEX RIVNUT	8
4	DTS-42-LK-BASE	.25" CRS	1
5	DTS-42-LK-COVER	.06 CRS	1
6	DTS-42-LK-LEGS	2X6X1/8 AL RECT TUBING	1
7	DTS-42-LK-PAN	12GA CRS	1
8	DTS-42-LK-SLANT-1	1/8" AL	1
9	DTS-42-LK-SLANT-2	2X6X1/8 AL RECT TUBING	1
10	DTS-42-LK-SLANT-3	2X6X1/8 AL RECT TUBING	1
11	DTS-42-LK-SLANT-4	1/8" AL	1
12	DTS-SLT-1	.075 CRS	1
13	DTS-SLT-2	.075 CRS	1
14	SS-032-2ZC	10-32 SS PEM NUT	9
15	SS61015-01	1" SS HINGE	2

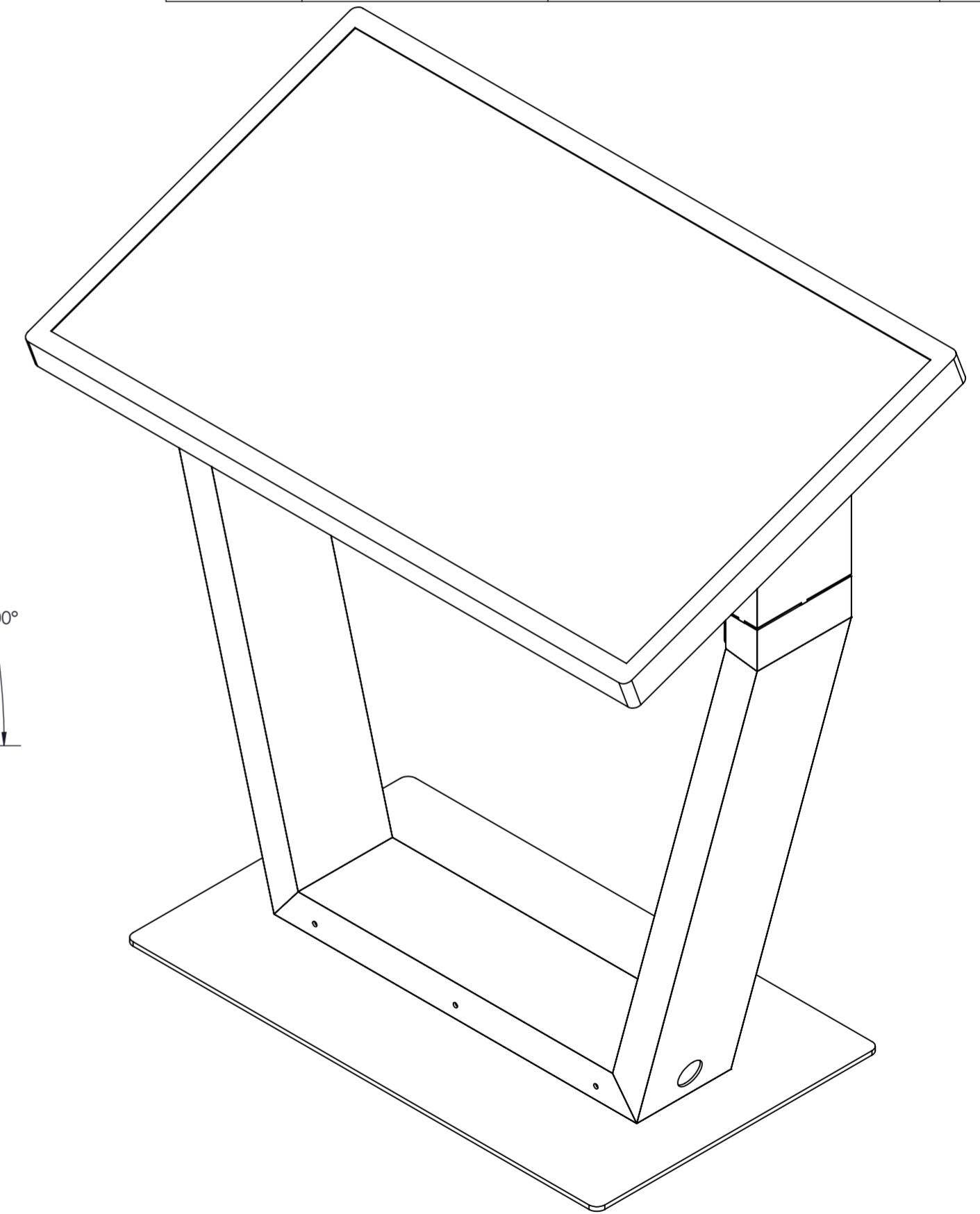

UNLESS OTHERWISE SPECIFIED: DIMENSIONS ARE IN INCHES SURFACE FINISH: TOLERANCES: LINEAR: .01 ANGULAR: .5		FINISH:	DEBUR AND BREAK SHARP EDGES	DO NOT SCALE DRAWING	REVISION
DRAWN:			TITLE:		
CHK'D:			DWG NO. DTS-42-LK		
APP'VD:			SCALE: 1:8		
MFG:			SHEET 1 OF 6		
G.A.:			A2		
MATERIAL:			WEIGHT:		

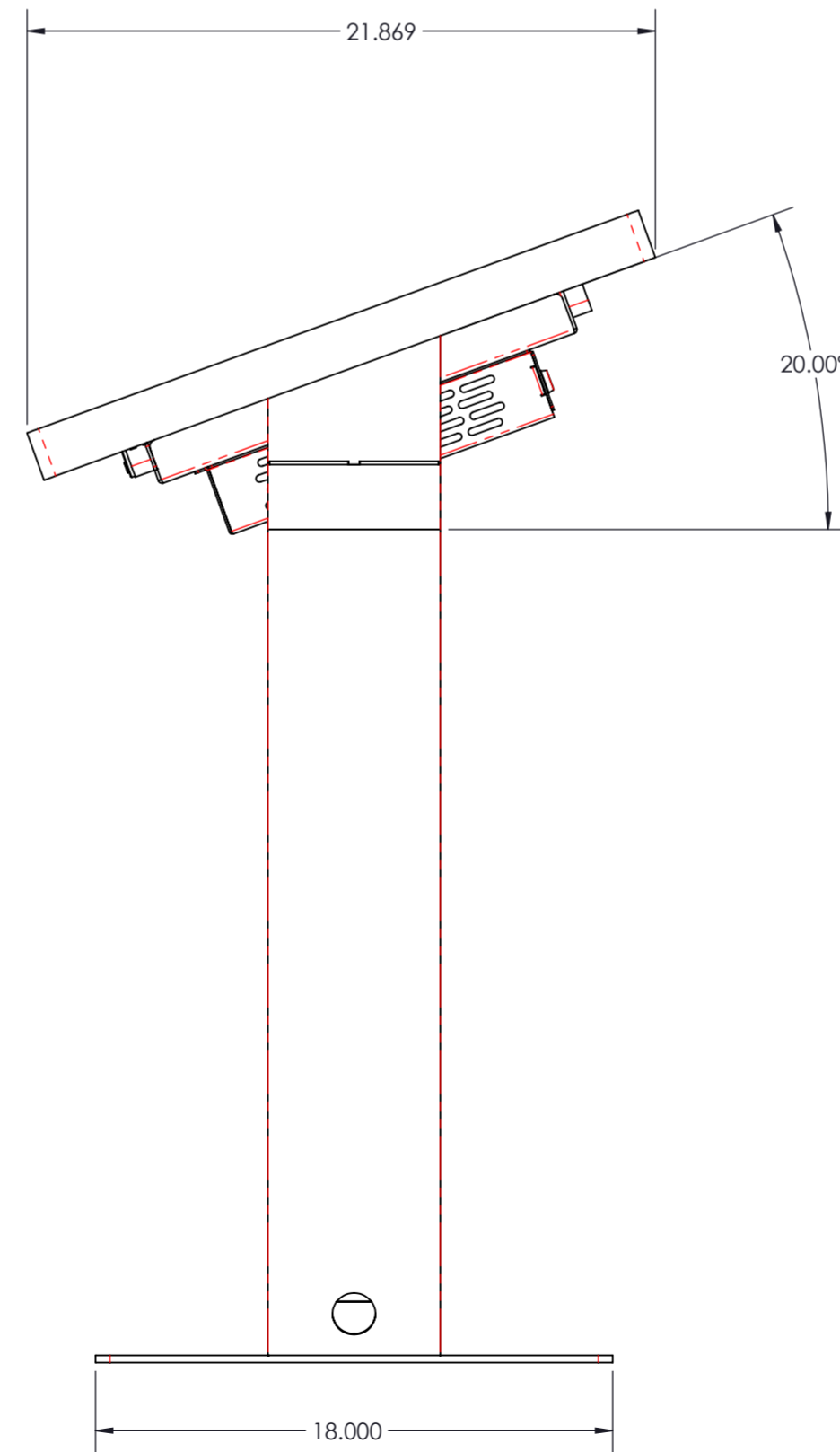
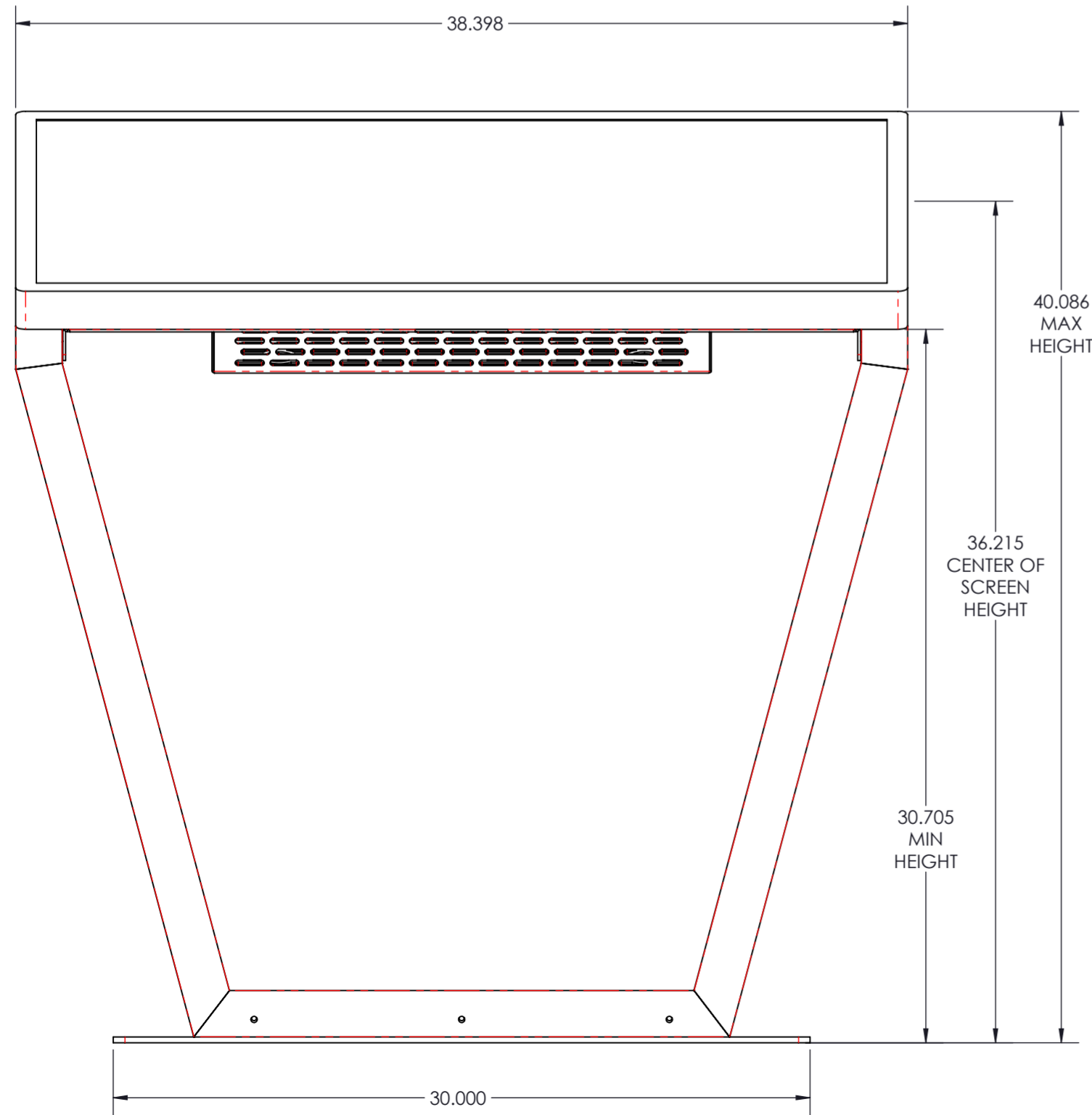
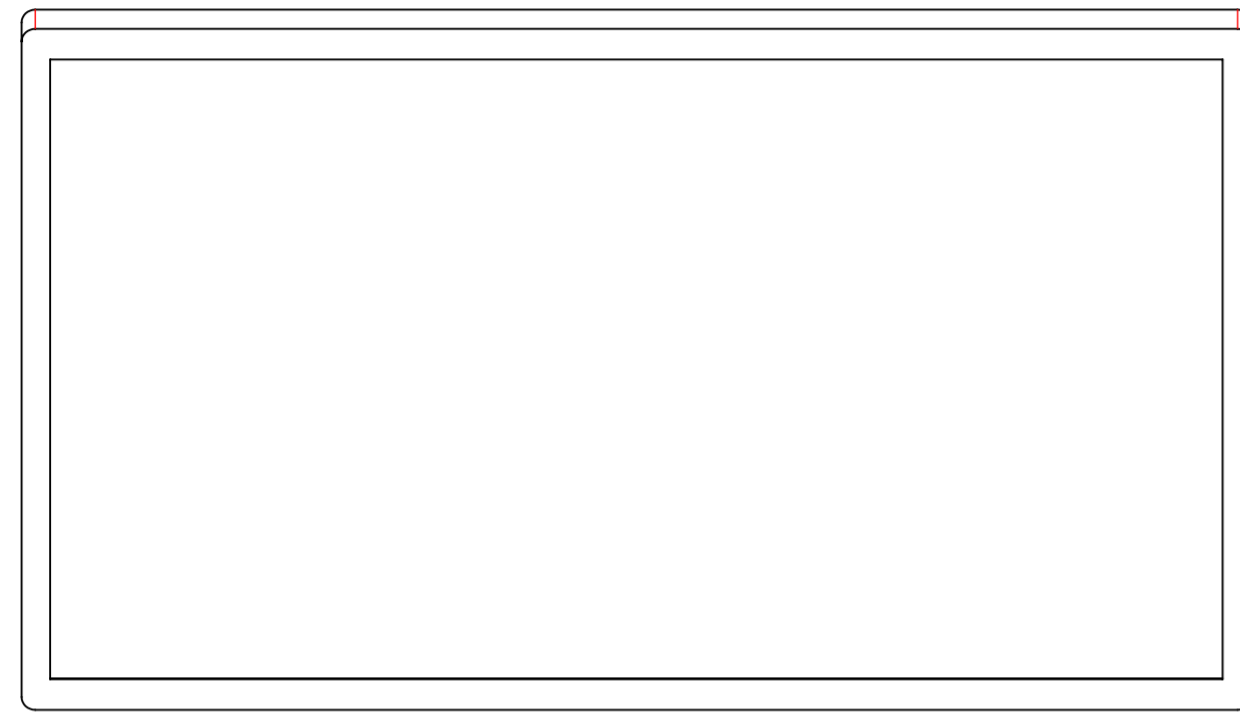
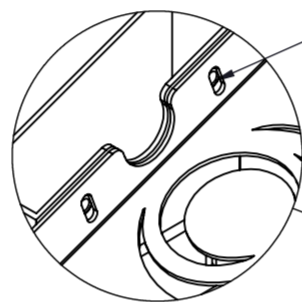
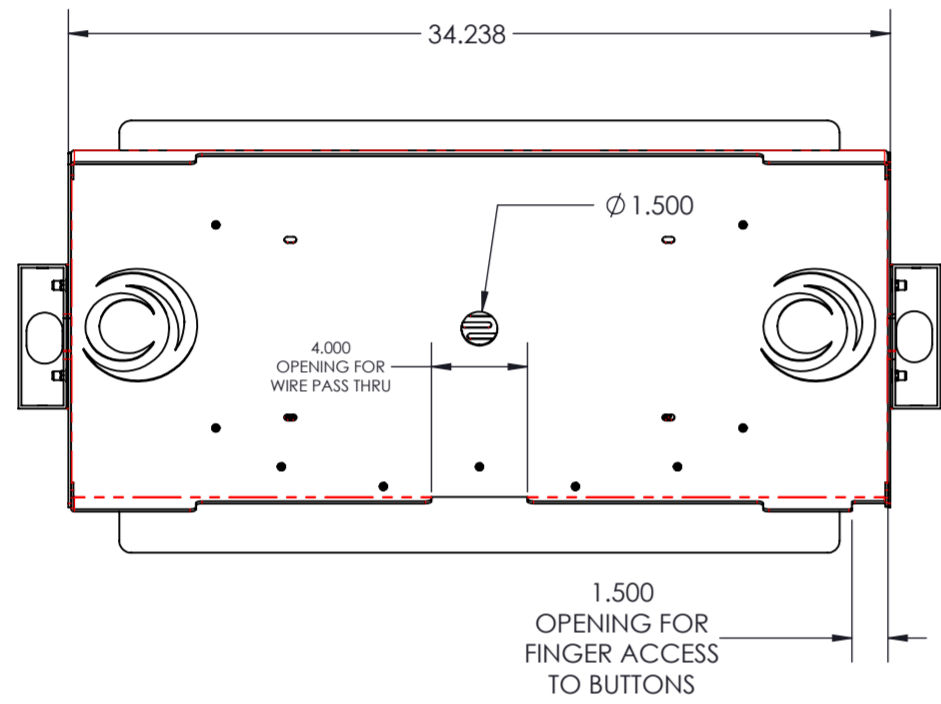

DETAIL C
SCALE 1 : 4

1/4-20 HEX RIVNUT
IN TUBING TO BOLT
PAN INTO. NO NEED
TO REACH INSIDE
TUBING.

1.409
INTERNAL HEIGHT

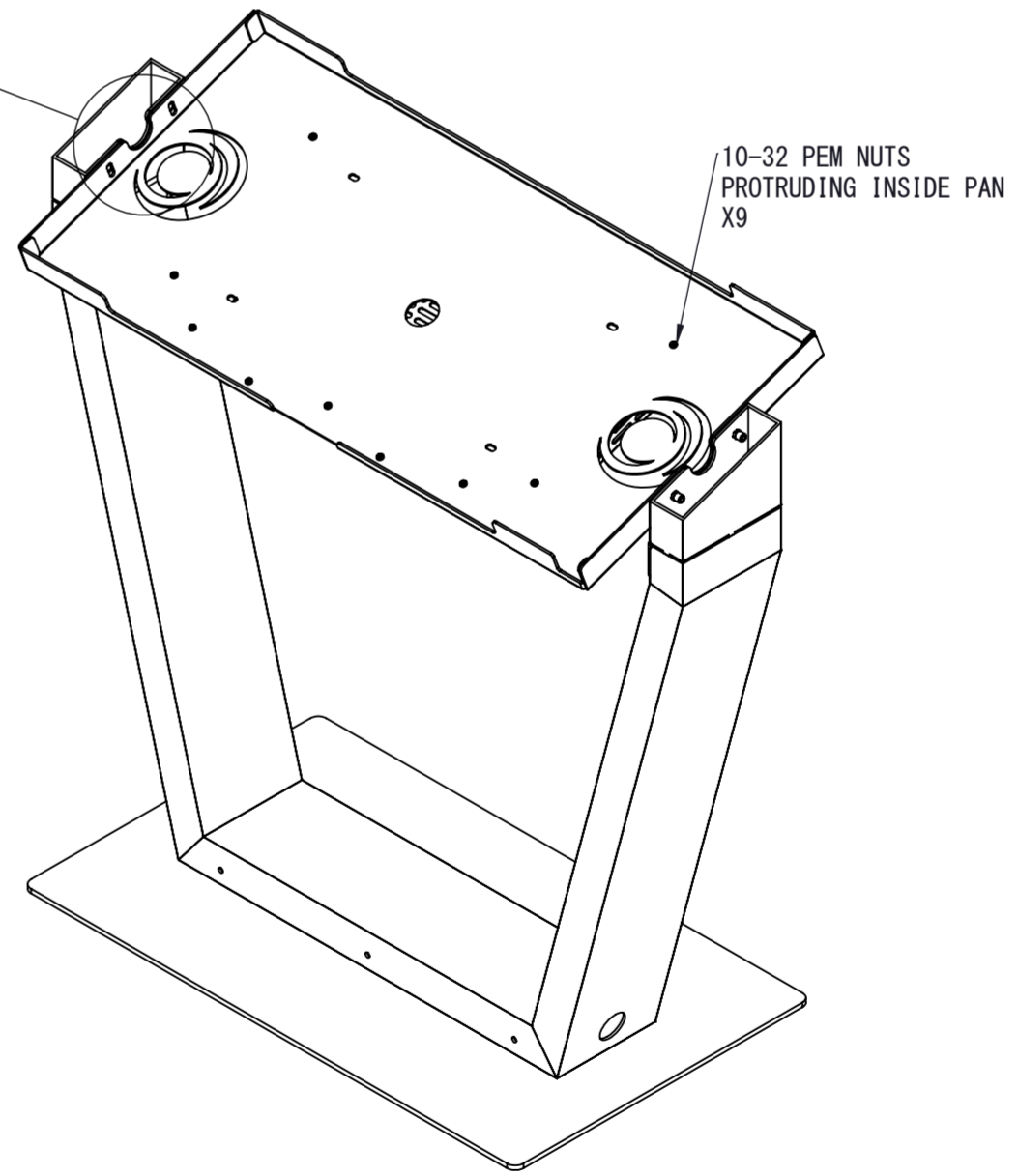
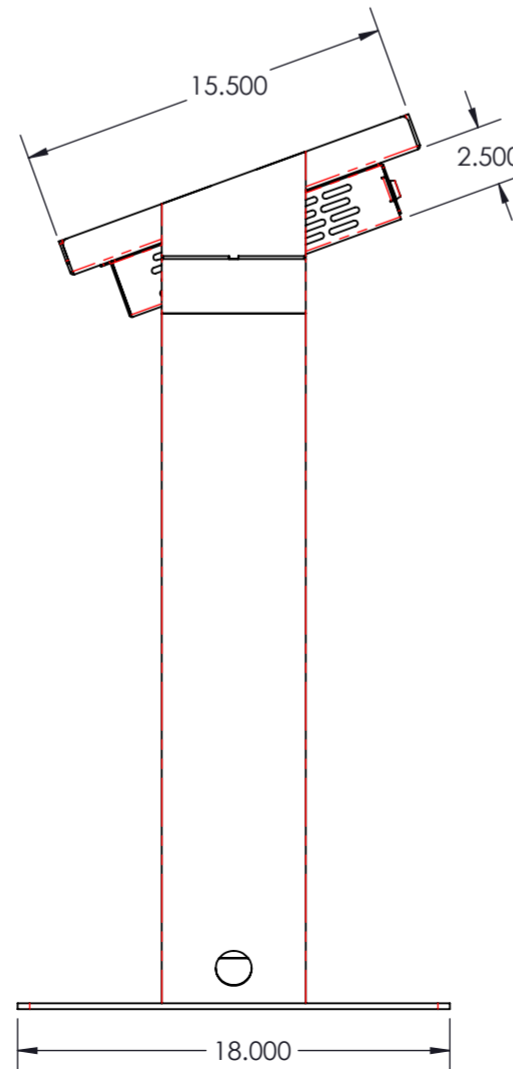
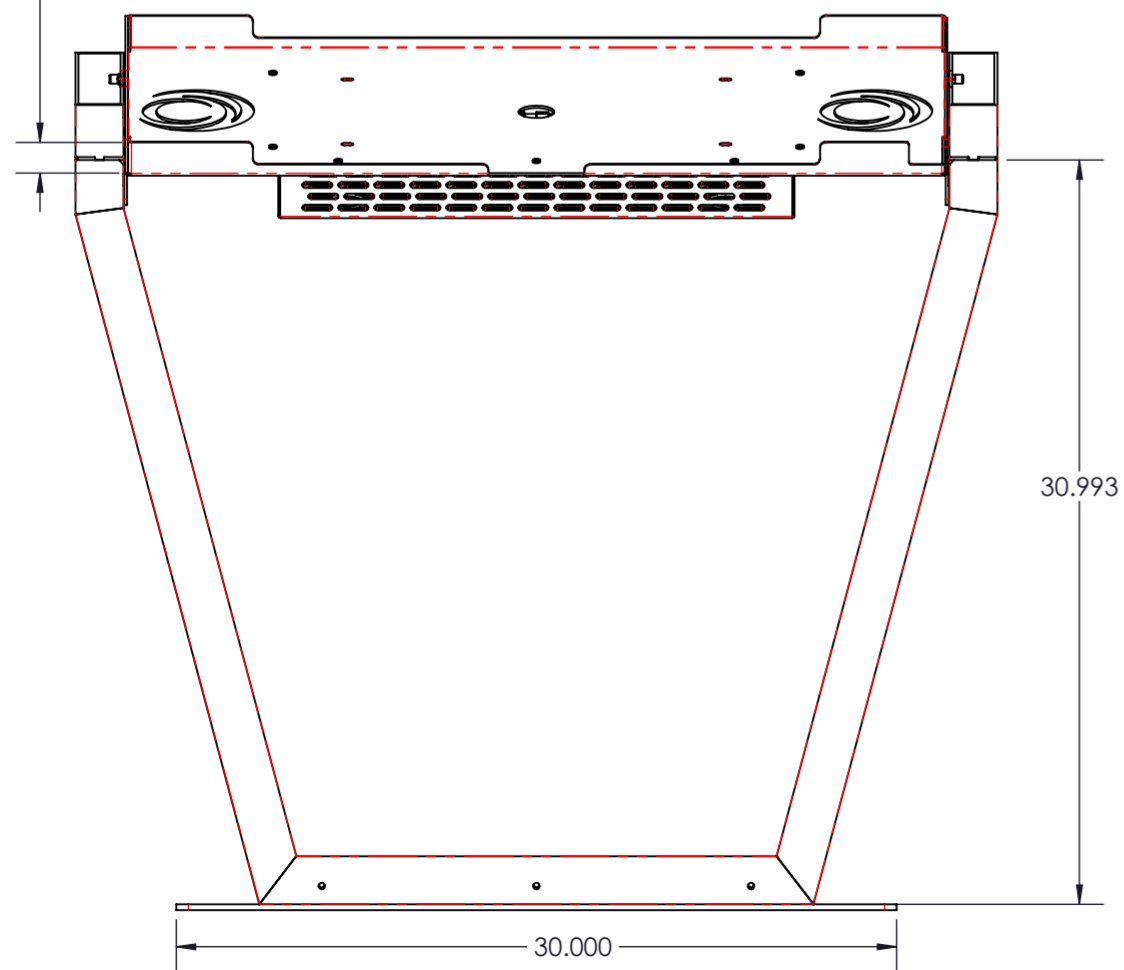

UNLESS OTHERWISE SPECIFIED: DIMENSIONS ARE IN INCHES SURFACE FINISH: TOLERANCES: LINEAR: .01 ANGULAR: .5		FINISH:	DEBUR AND BREAK SHARP EDGES	DO NOT SCALE DRAWING	REVISION
				Digital Touch Systems	
DRAWN:	NAME	SIGNATURE	DATE	TITLE:	
CHK'D:					
APP'V'D:					
MFG:					
Q.A.				MATERIAL:	DWG NO. DTS-42-LK
				WEIGHT:	A2
				SCALE: 1:16	SHEET 2 OF 6

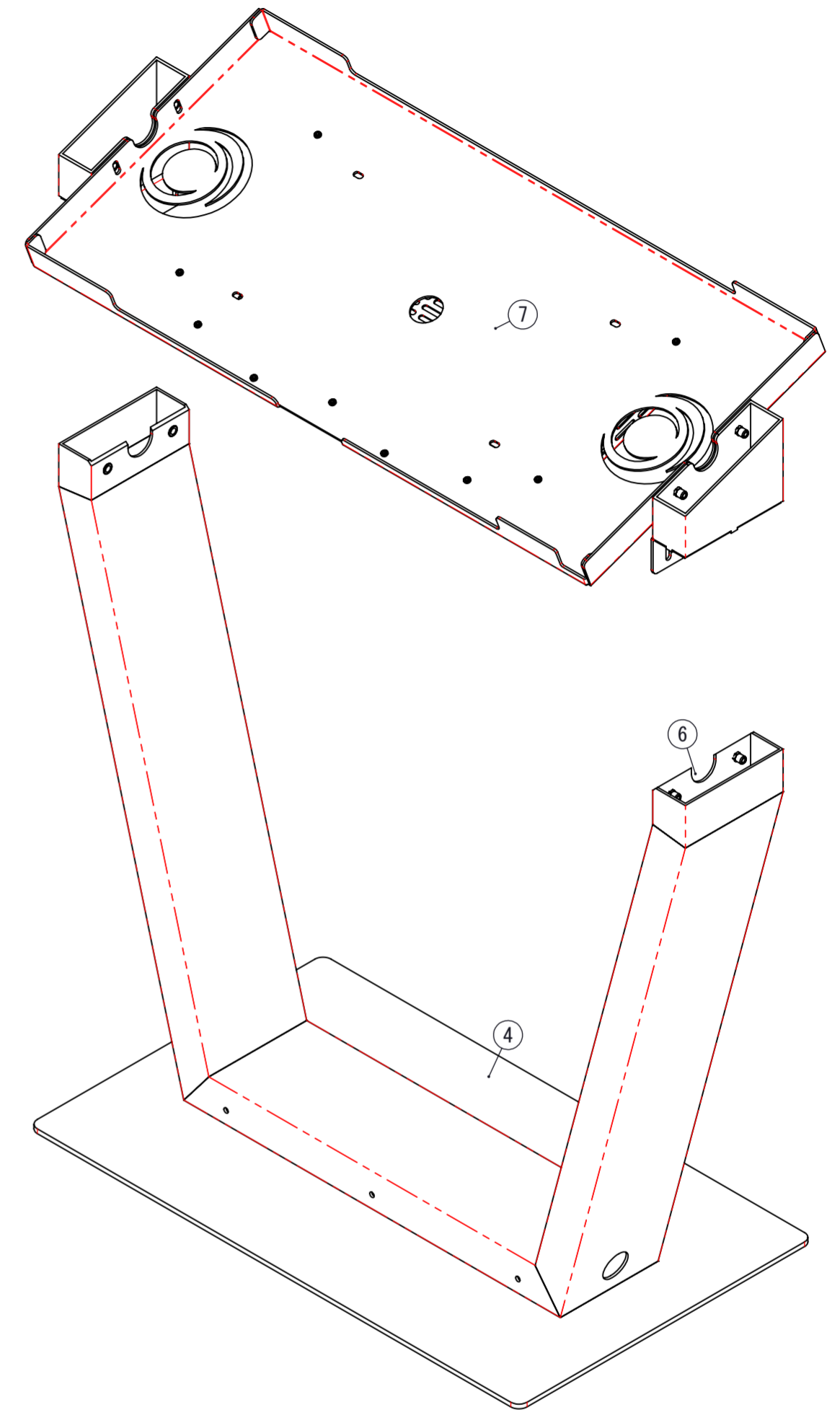
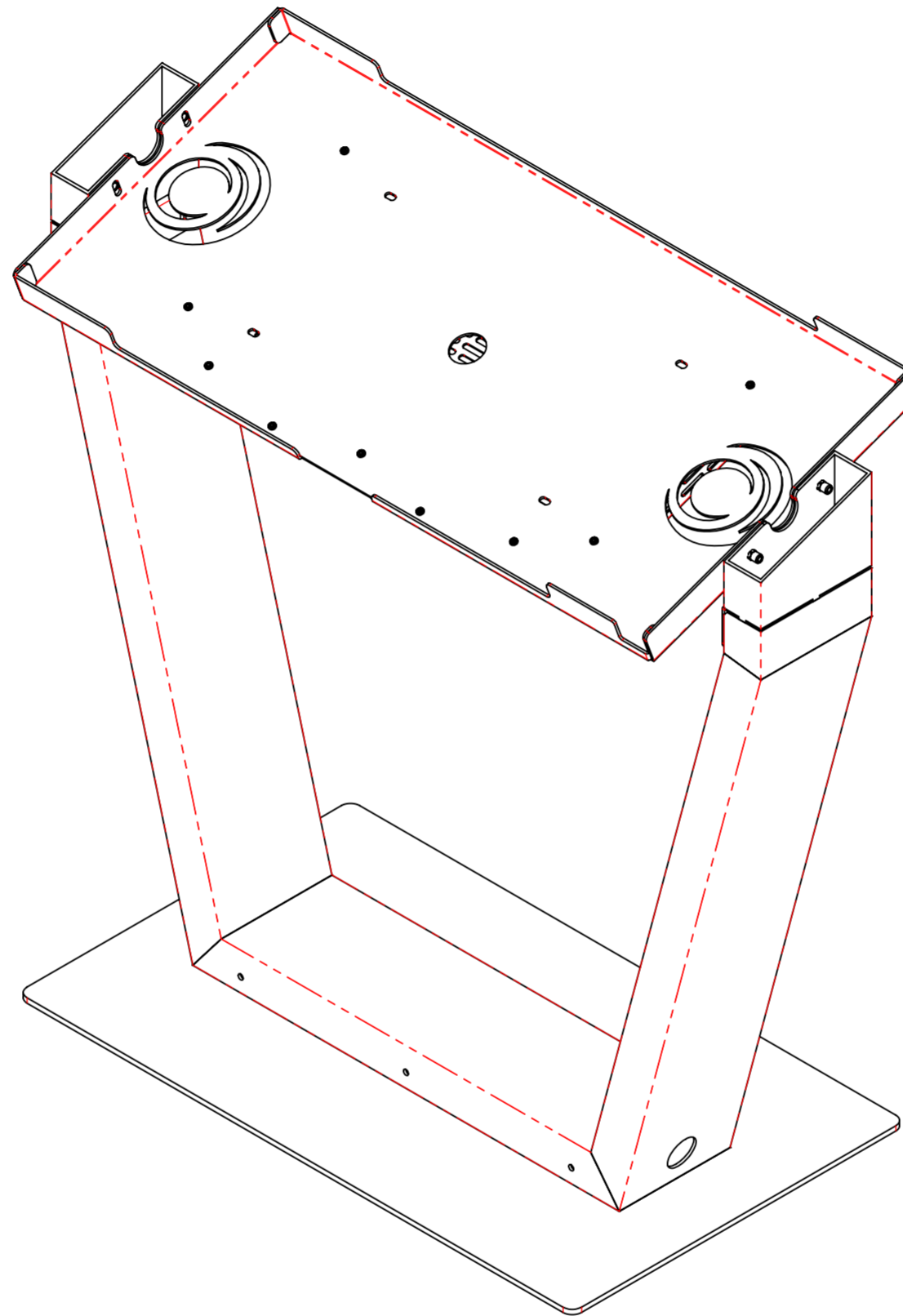
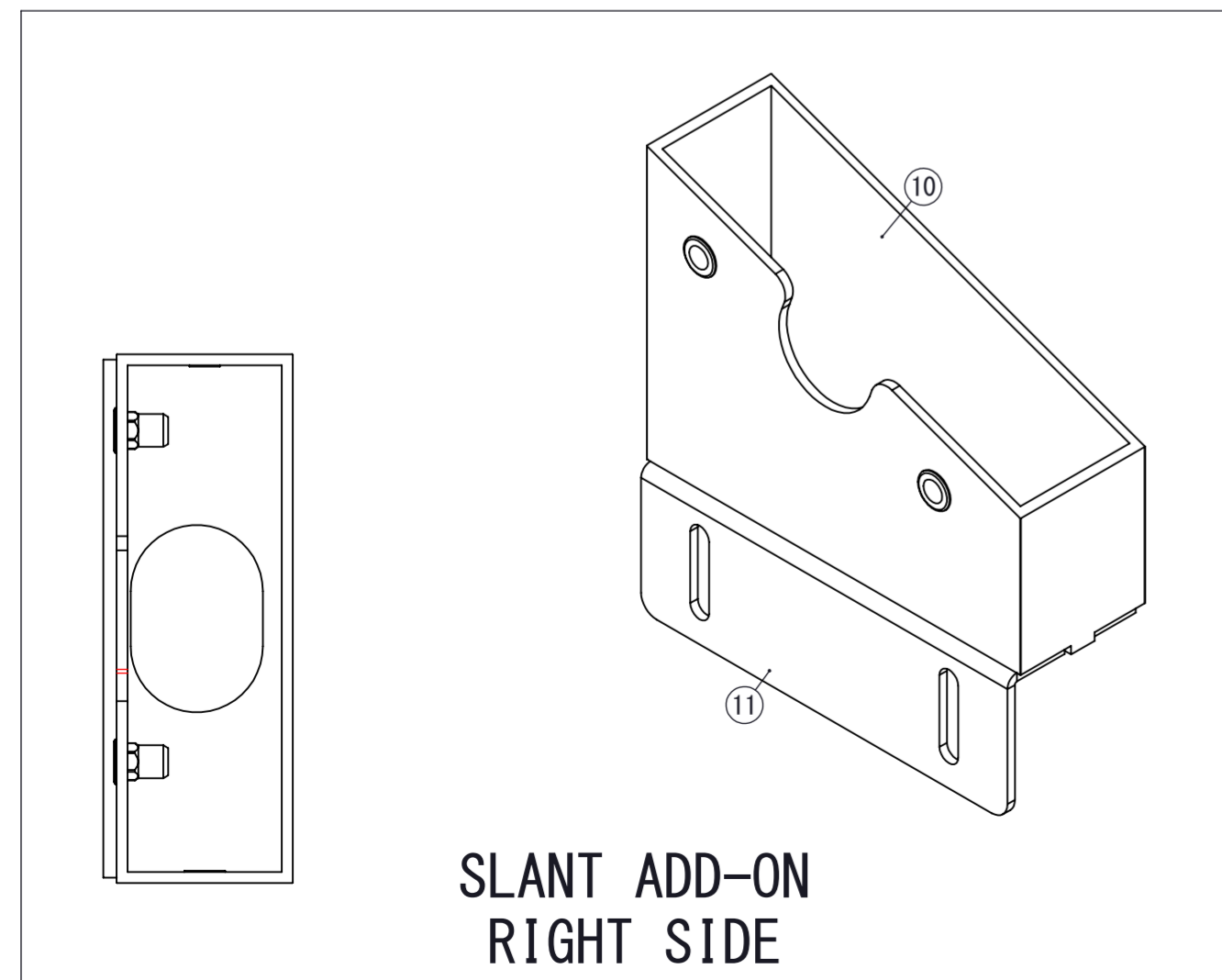
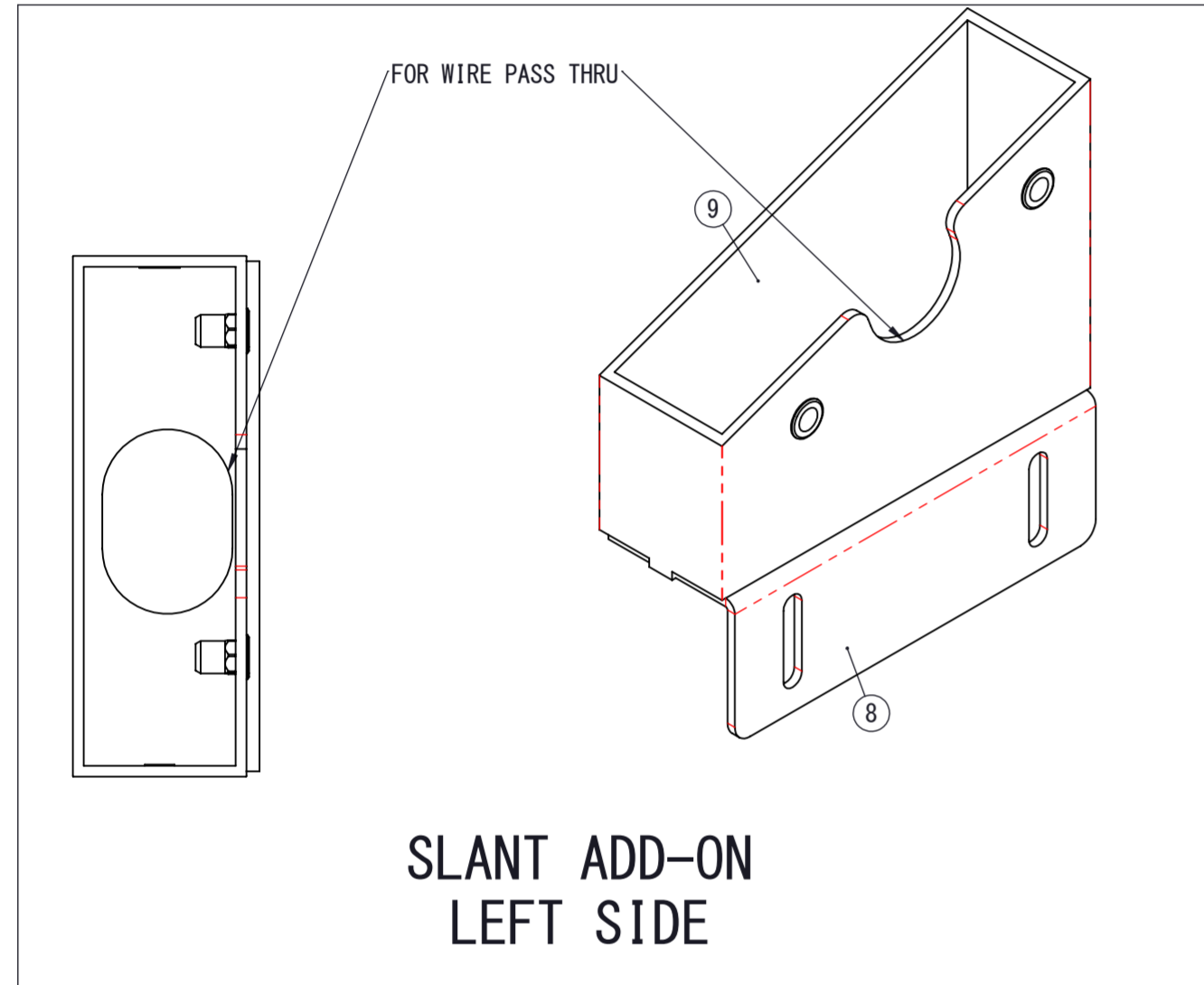

UNLESS OTHERWISE SPECIFIED: DIMENSIONS ARE IN INCHES SURFACE FINISH: TOLERANCES: LINEAR: .01 ANGULAR: .5		FINISH:	DEBUR AND BREAK SHARP EDGES		DO NOT SCALE DRAWING	REVISION
					Digital Touch Systems	
DRAWN:	NAME	SIGNATURE	DATE	TITLE:		
CHK'D:						
APP'V'D:						
MFG:						
Q.A.				MATERIAL:	DWG NO.	DTS-42-LK
				WEIGHT:	SCALE: 1:6	A2
					SHEET 4 OF 6	

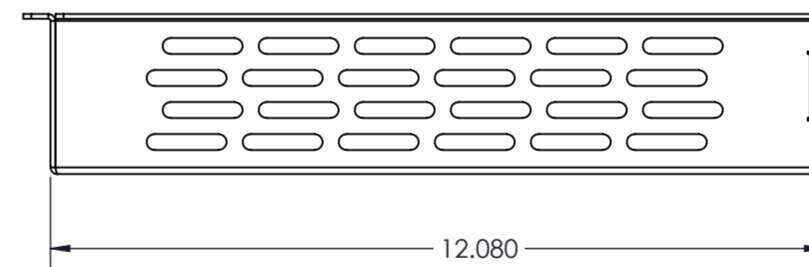
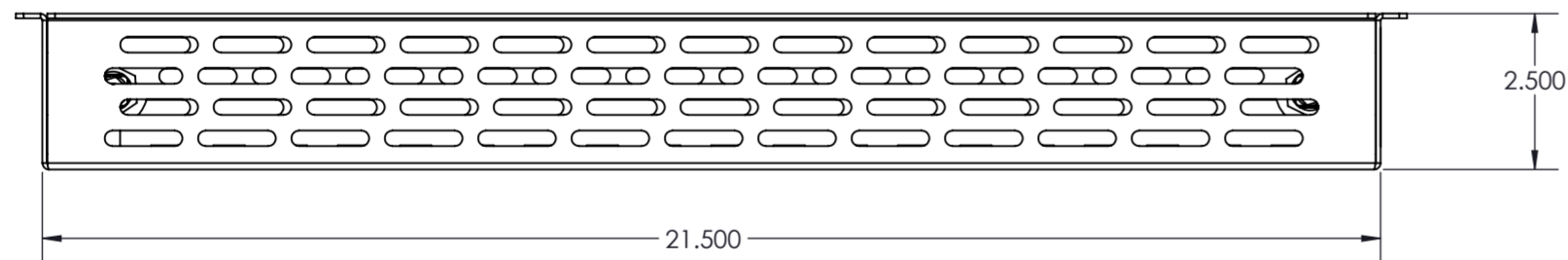
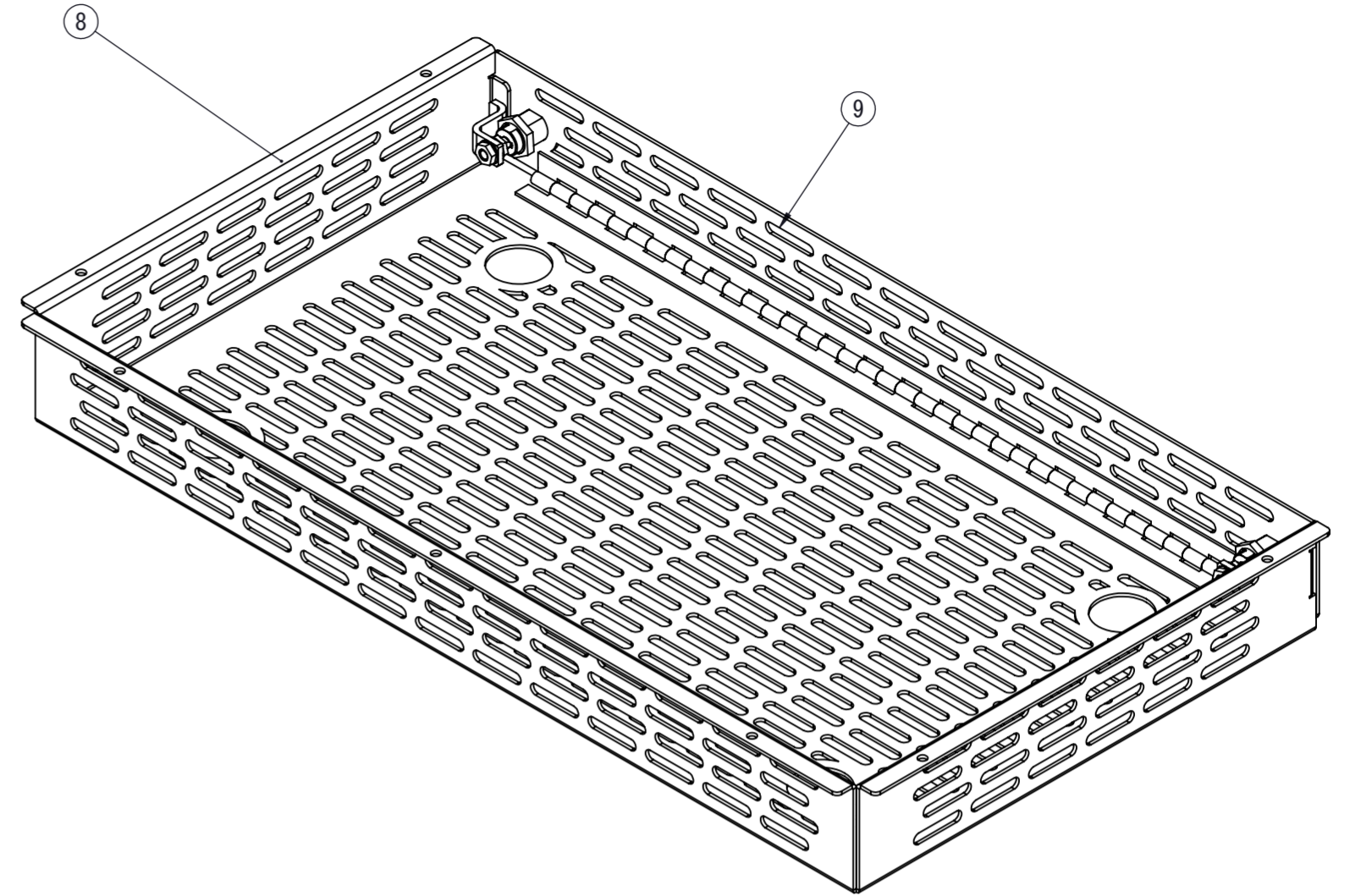
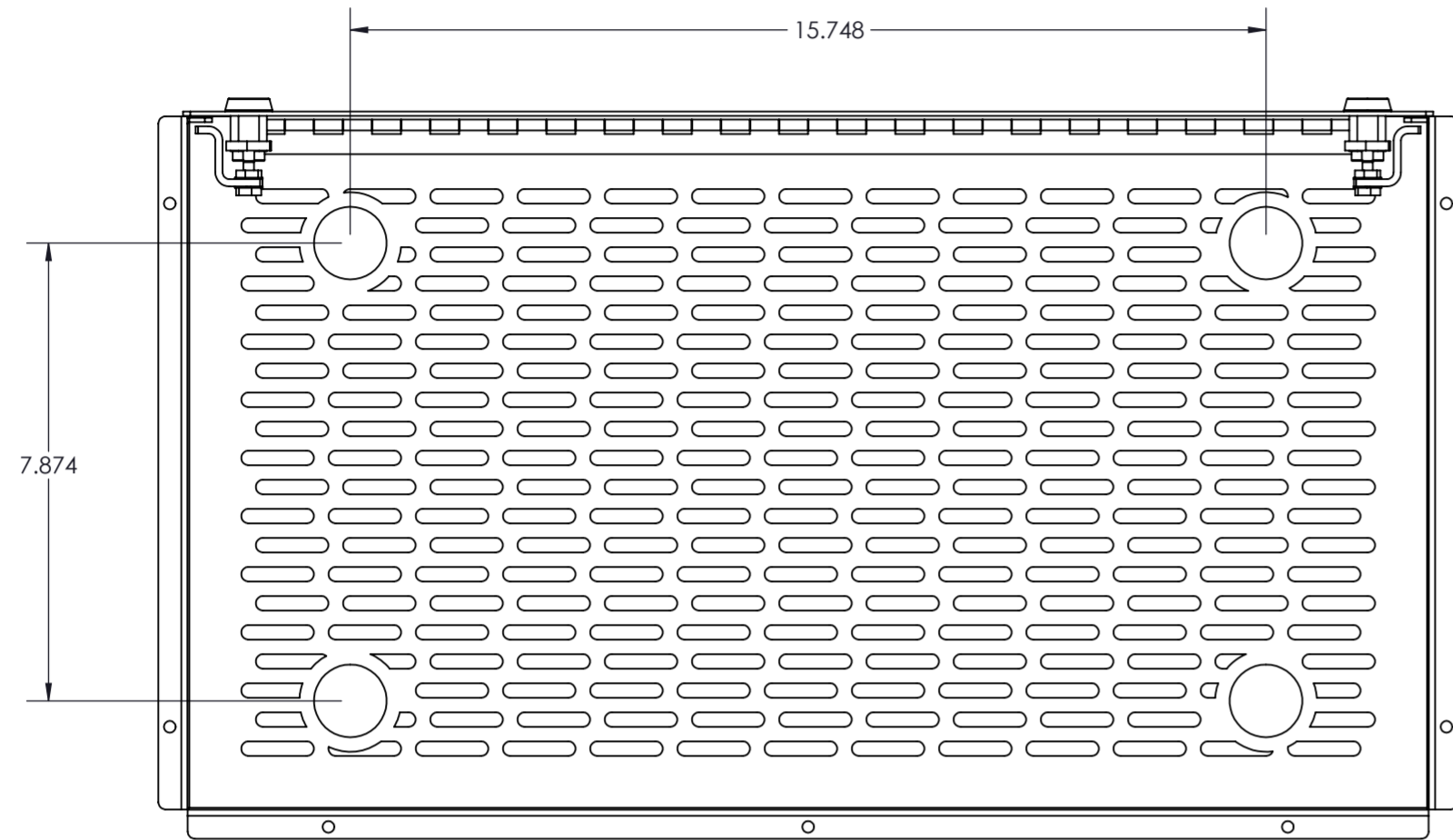

UNLESS OTHERWISE SPECIFIED: DIMENSIONS ARE IN INCHES SURFACE FINISH: TOLERANCES: LINEAR: .01 ANGULAR: .5		FINISH:	DEBUR AND BREAK SHARP EDGES	DO NOT SCALE DRAWING	REVISION
				Digital Touch Systems	
DRAWN:		NAME	SIGNATURE	DATE	TITLE:
CHK'D:					
APP'VD:					
MFG:					
Q.A.					
				MATERIAL:	DWG NO.
					DTS-42-LK
				WEIGHT:	SCALE: 1:8
				SHEET 3 OF 6	A2