

ITEM NO.	PART NUMBER	DESCRIPTION	QTY.
1	3-13BK01	STANDARD DIGITAL TOUCH LOCK	2
2	AEHS8-420-165	1/4-20 HEX RIVNUT	8
3	DTS-46-LKN-BASE	.25" CRS	1
4	DTS-46-LKN-COVER	.06 CRS	1
5	DTS-46-LKN-LEGS	2X6X1/8 AL RECT TUBING	1
6	DTS-46-LKN-PAN	12GA CRS	1
7	DTS-46-LKN-SLANT-1	1/8" AL	1
8	DTS-46-LKN-SLANT-2	2X6X1/8 AL RECT TUBING	1
9	DTS-46-LKN-SLANT-3	2X6X1/8 AL RECT TUBING	1
10	DTS-46-LKN-SLANT-4	1/8" AL	1
11	DTS-SLT-1	.075 CRS	1
12	DTS-SLT-2	.075 CRS	1
13	SS-032-2ZC	10-32 SS PEM NUT	9
14	SS61015-01	1" SS HINGE	2
21	NEP460-002_ASSEMBLY(191216)	46" SCREEN FOR REFERENCE	1

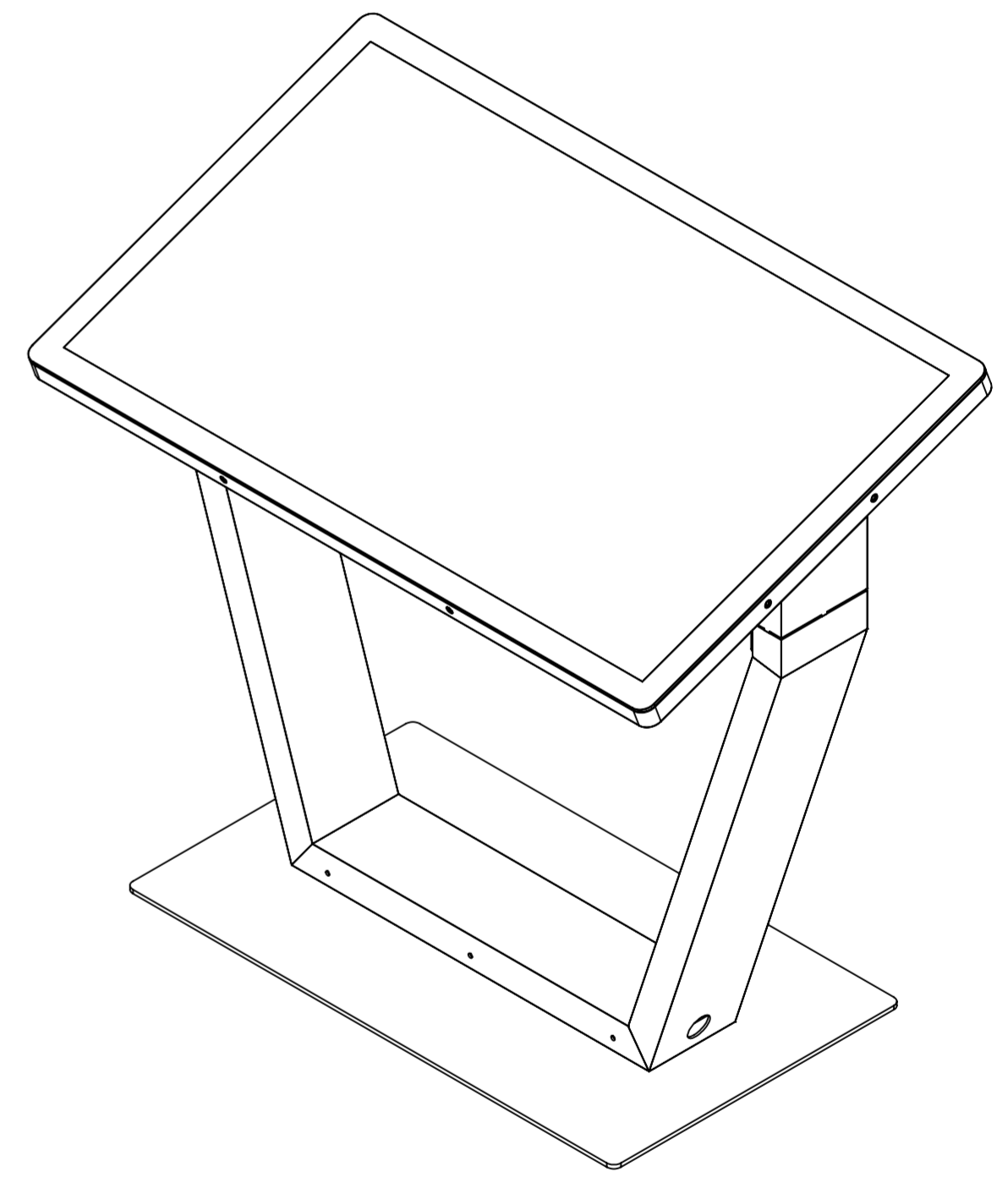

UNLESS OTHERWISE SPECIFIED: DIMENSIONS ARE IN INCHES SURFACE FINISH: TOLERANCES: LINEAR: .01 ANGULAR: .5		FINISH:	DEBUR AND BREAK SHARP EDGES	DO NOT SCALE DRAWING	REVISION
DRAWN:			TITLE:		
CHKD:			DWG NO. DTS-46-LKN		
APP'VD:			SCALE: 1:16		
MFG:			SHEET 1 OF 6		
Q.A.			A2		
MATERIAL:			WEIGHT:		

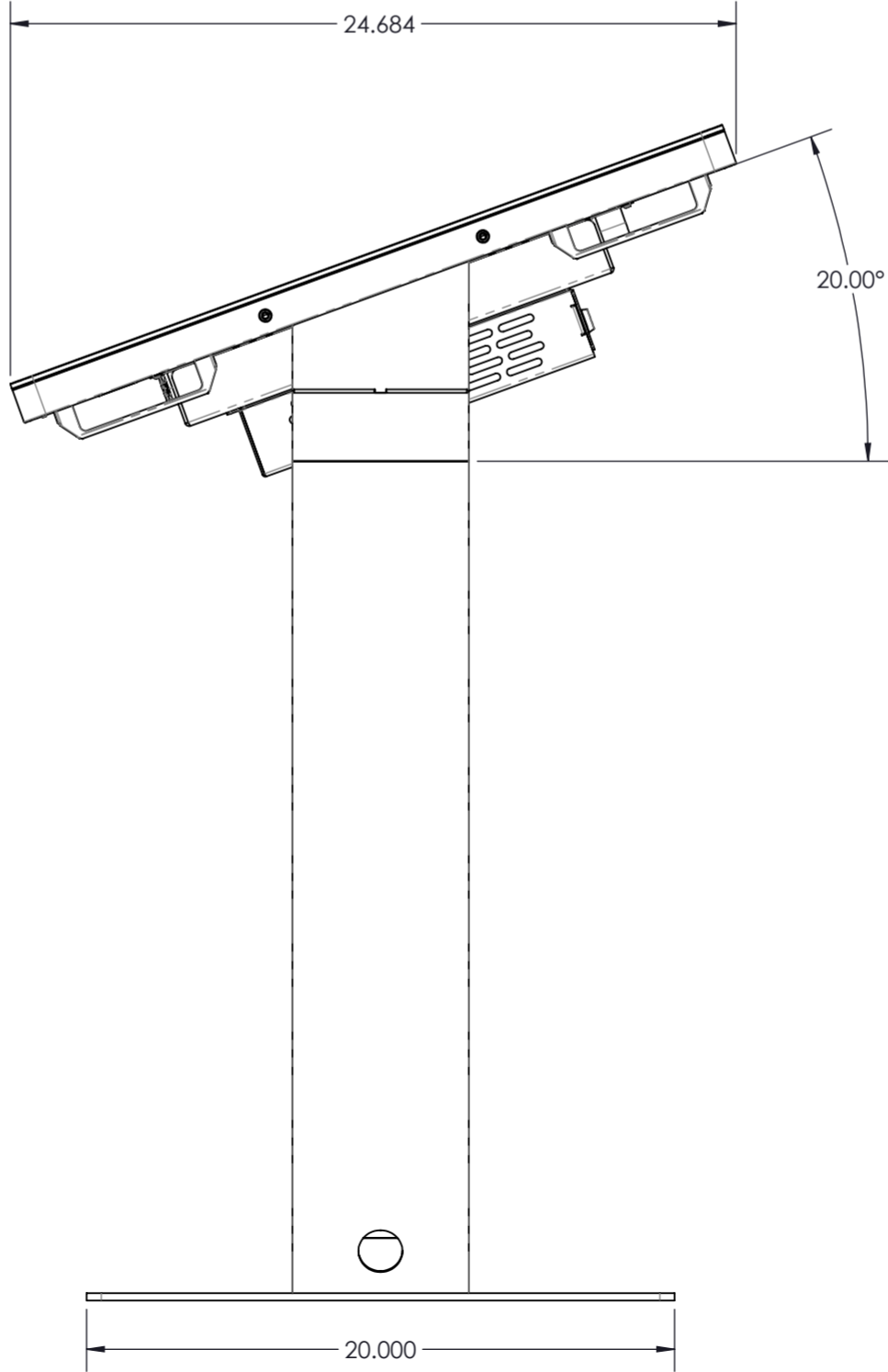
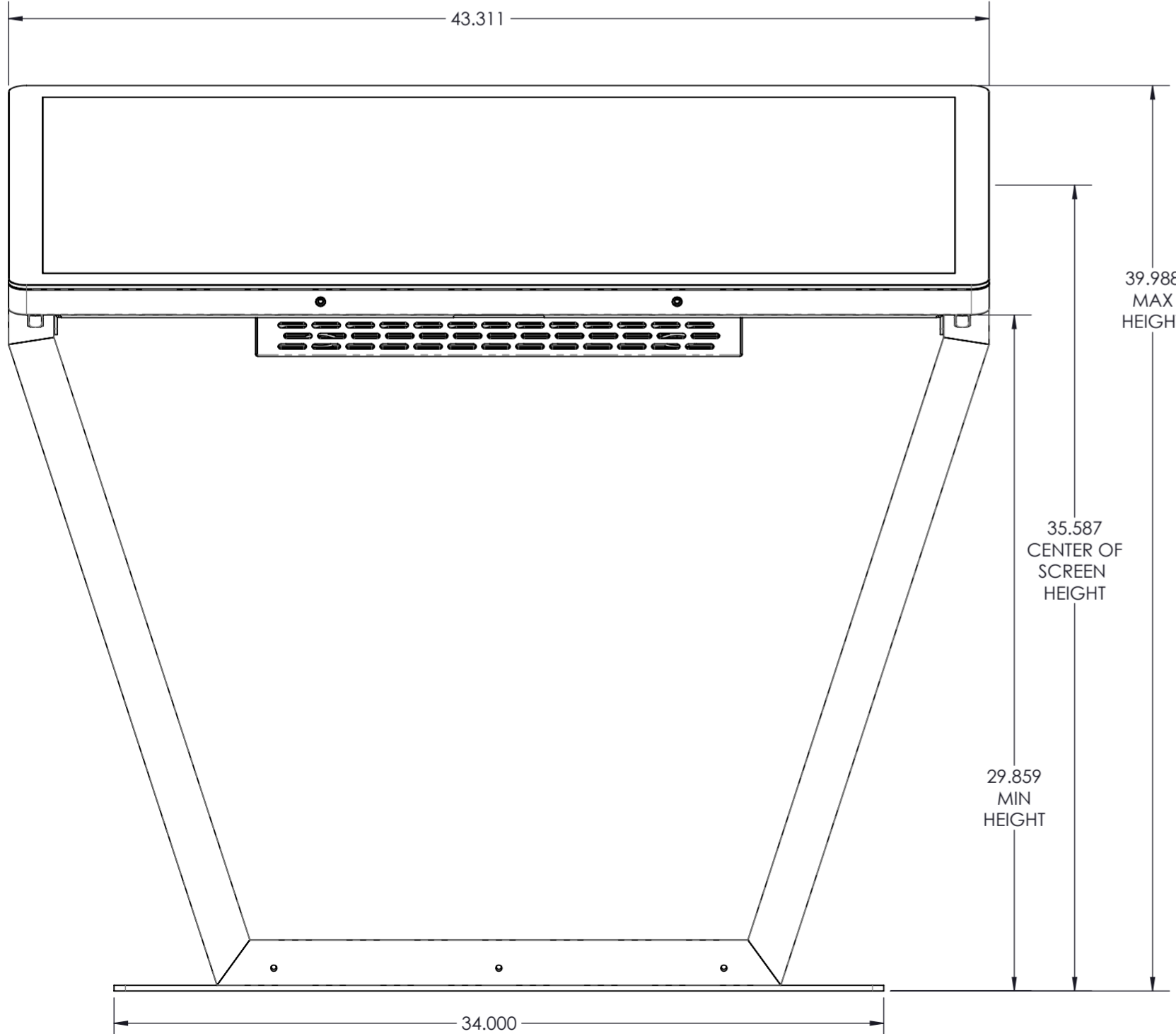
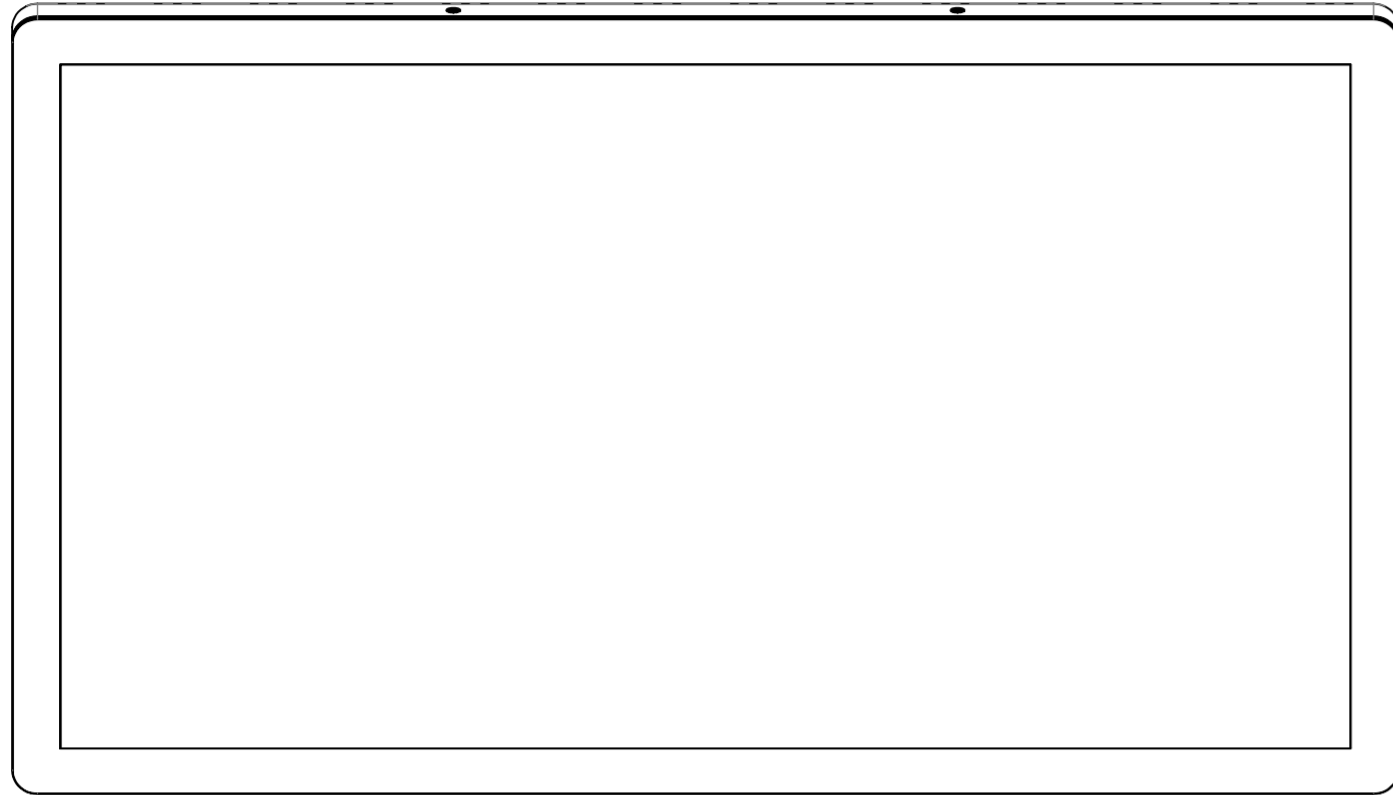
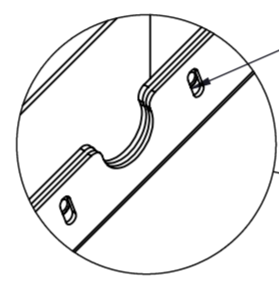
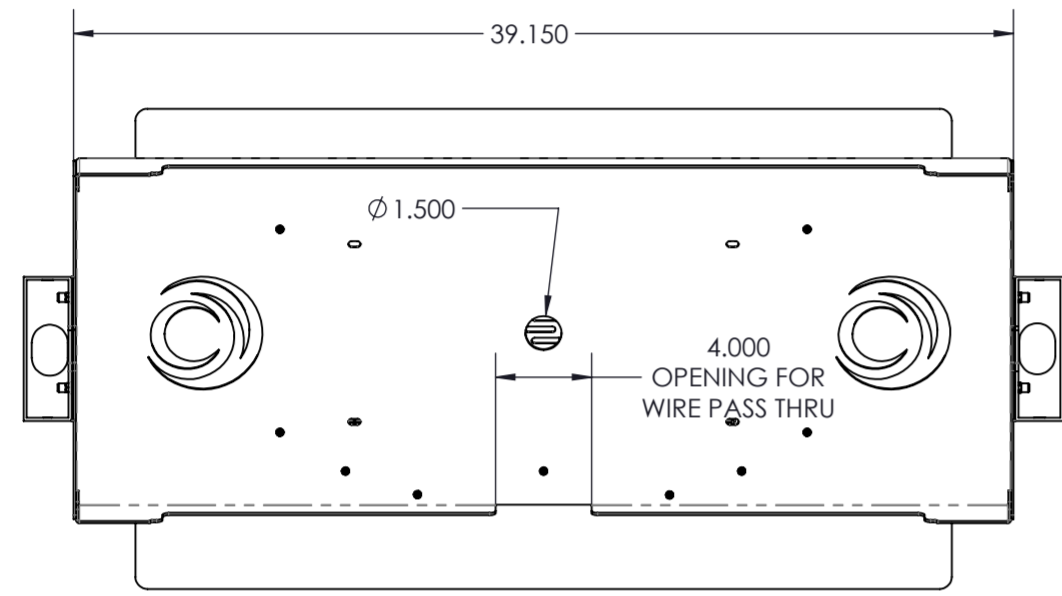

1/4-20 HEX RIVNUT
IN TUBING TO BOLT
PAN INTO. NO NEED
TO REACH INSIDE
TUBING.

DETAIL C
SCALE 1 : 4

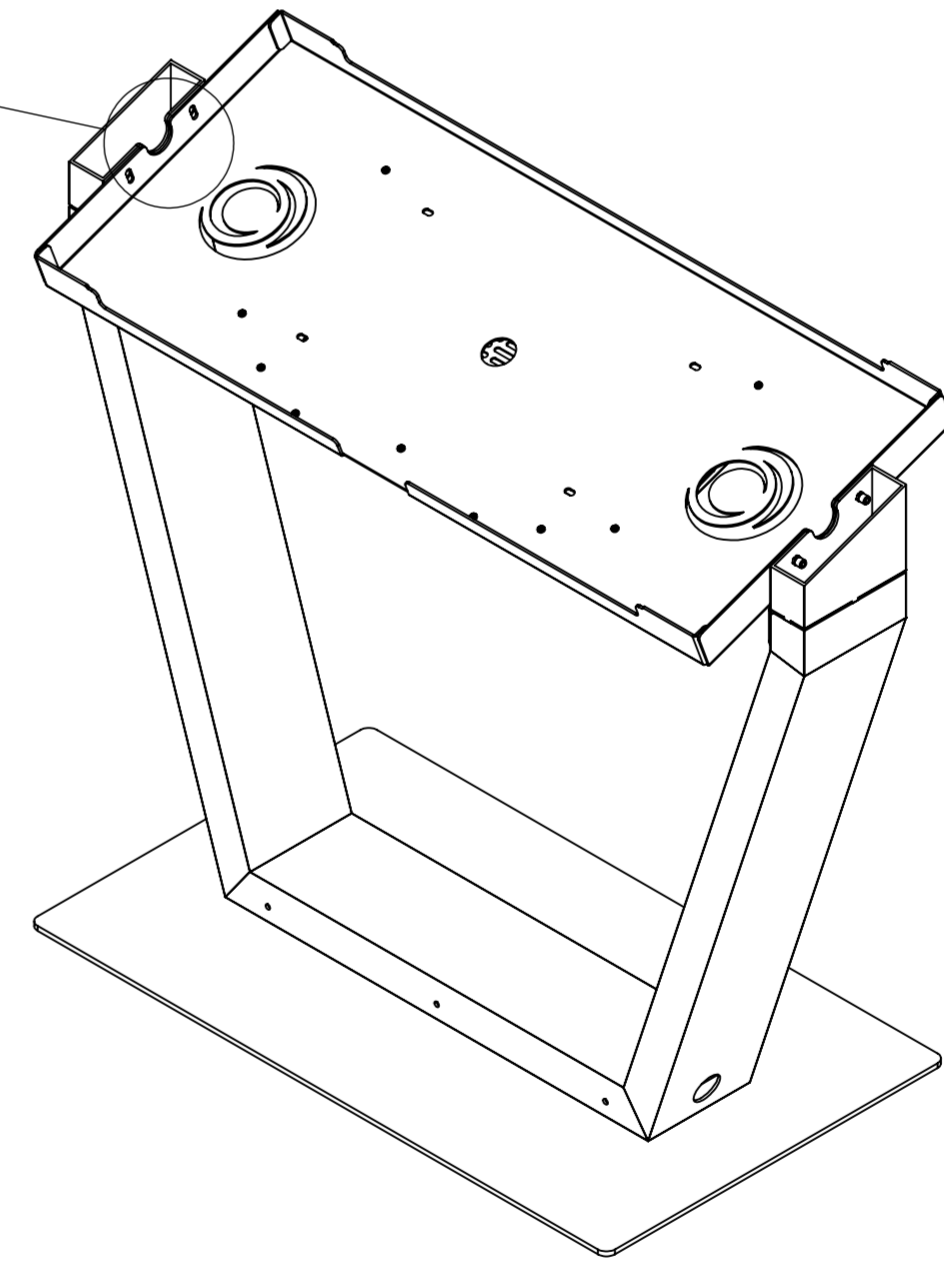
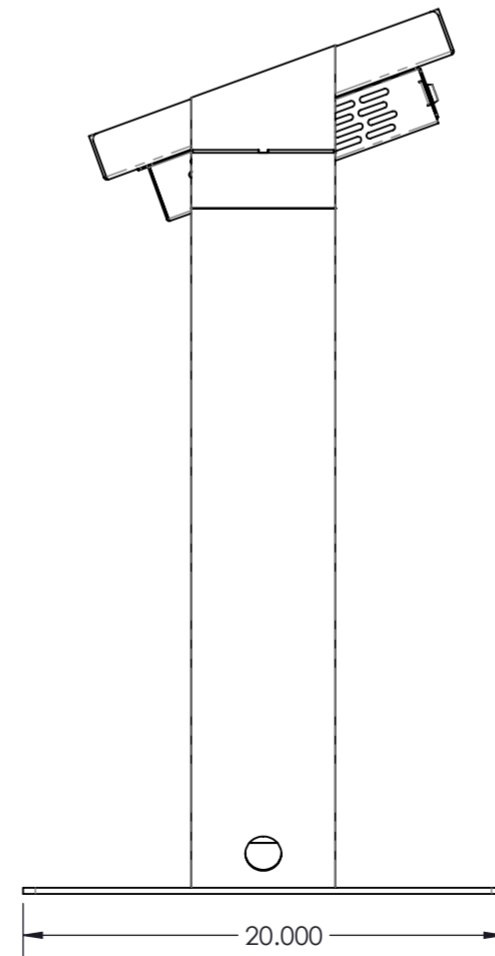
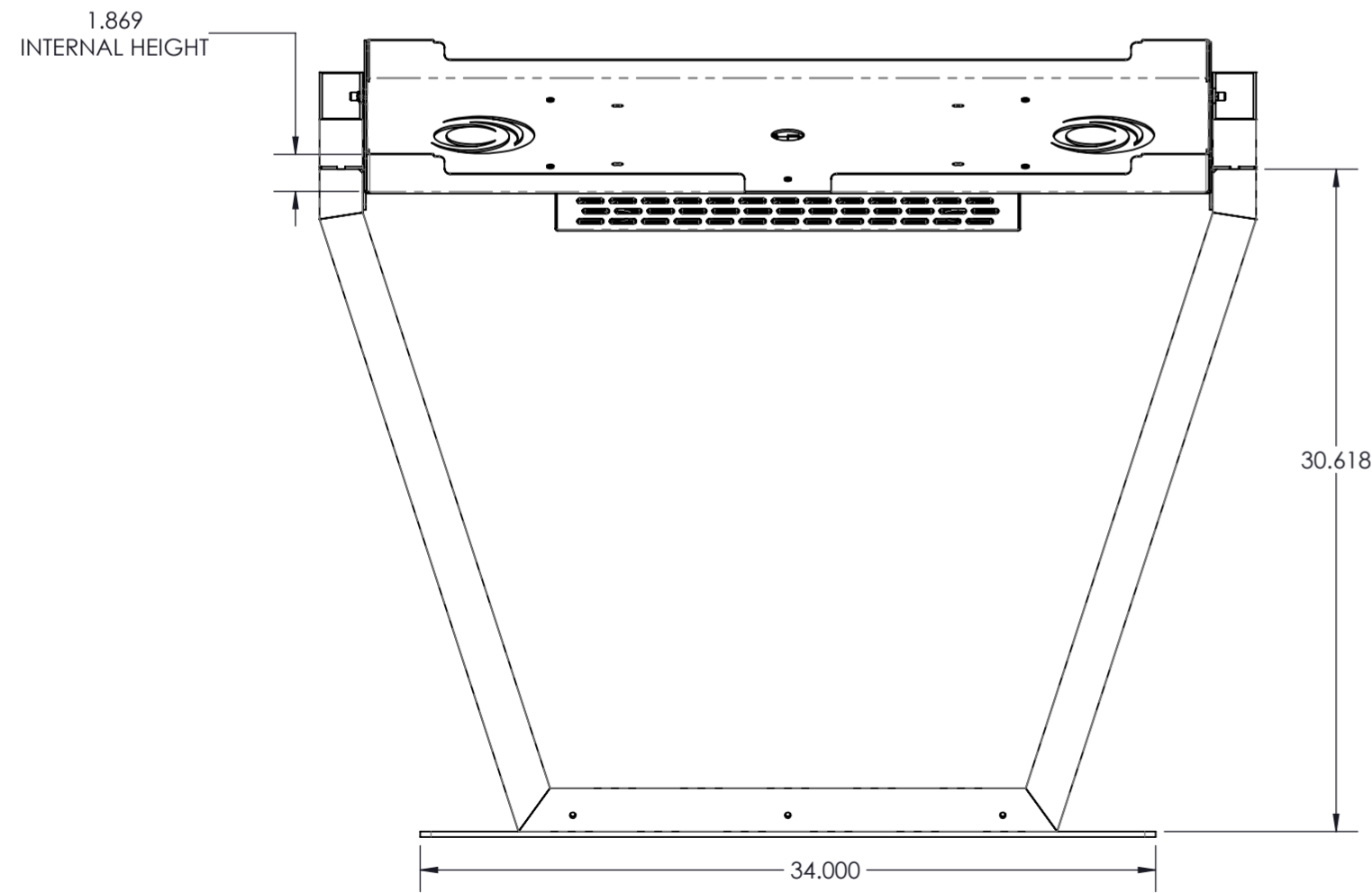

UNLESS OTHERWISE SPECIFIED: DIMENSIONS ARE IN INCHES SURFACE FINISH: TOLERANCES: LINEAR: .01 ANGULAR: .5		FINISH:	DEBUR AND BREAK SHARP EDGES	DO NOT SCALE DRAWING	REVISION
				Digital Touch Systems	
				TITLE:	
DRAWN:	NAME	SIGNATURE	DATE		
CHK'D:					
APP'V'D:					
MFG:					
Q.A.				MATERIAL:	DWG NO. DTS-46-LKN
				WEIGHT:	A2
				SCALE: 1:16	SHEET 2 OF 6

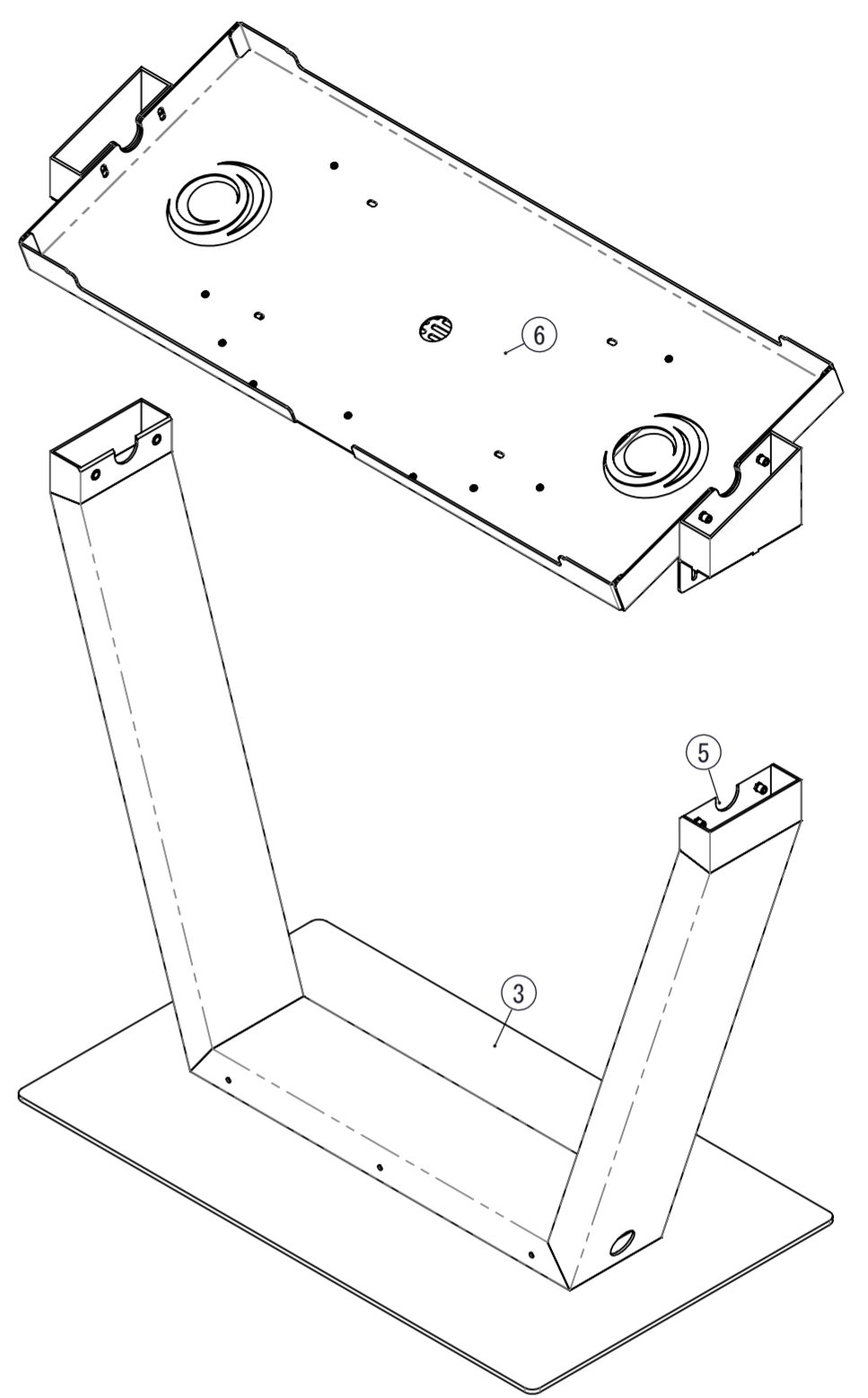
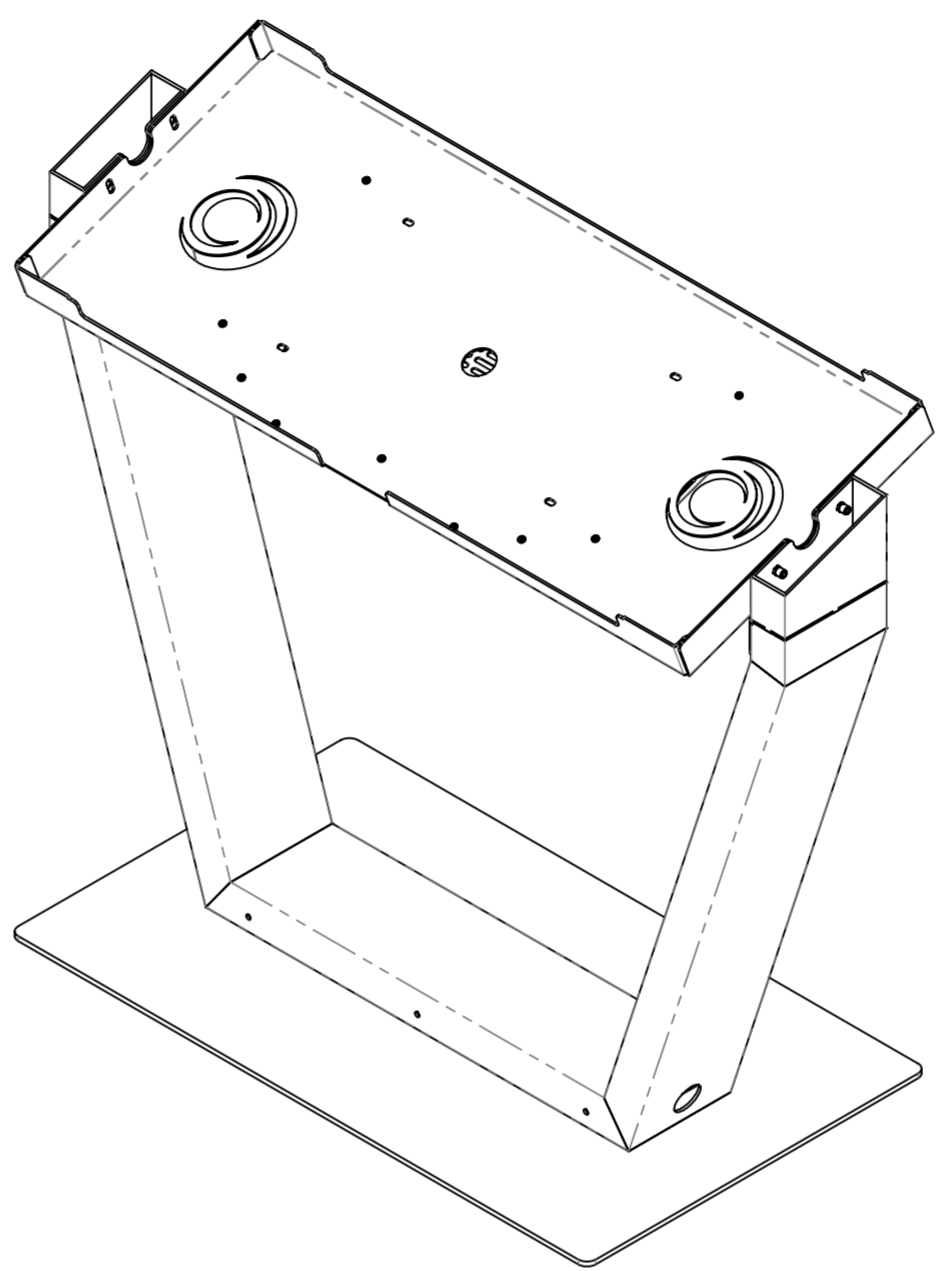
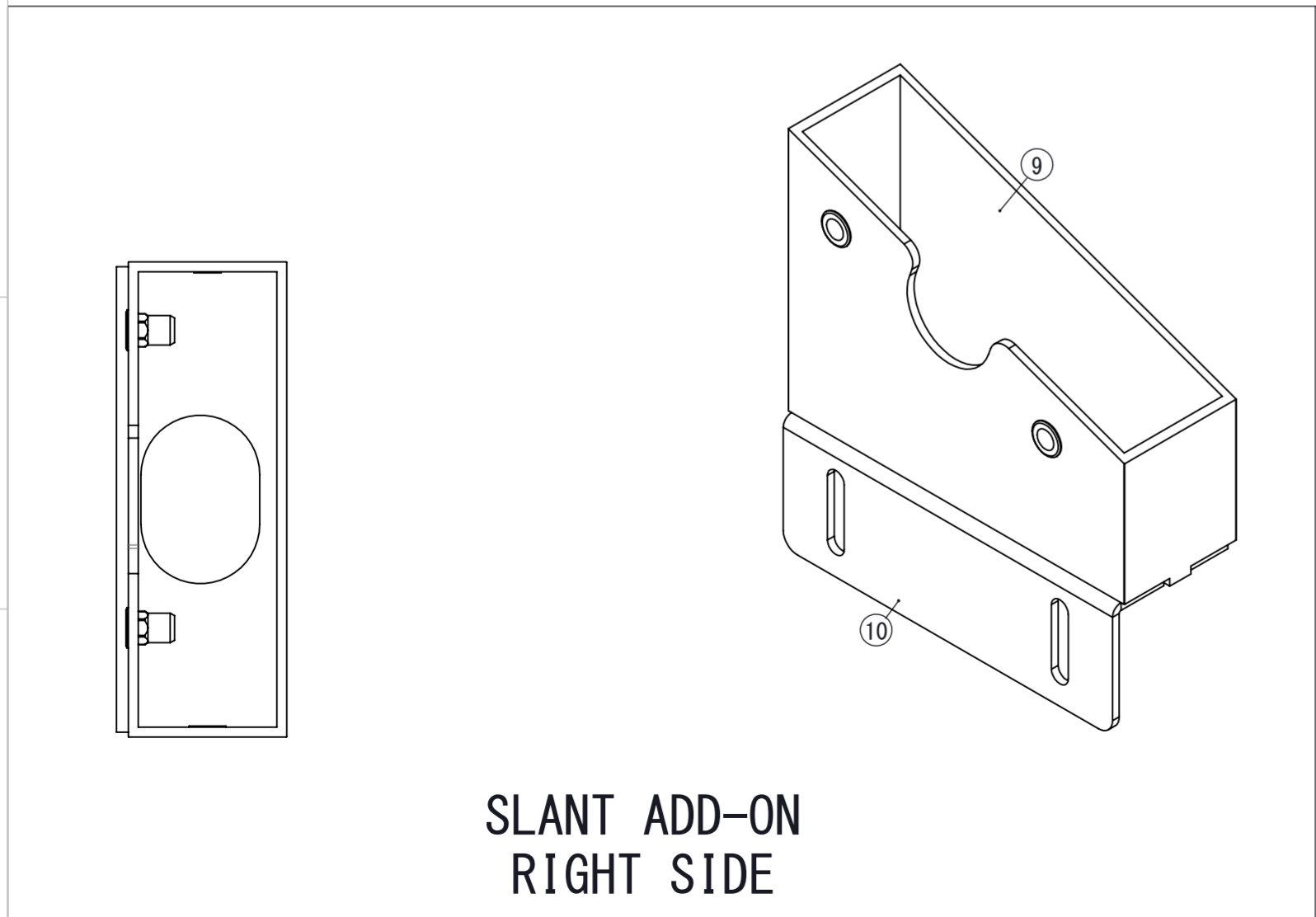
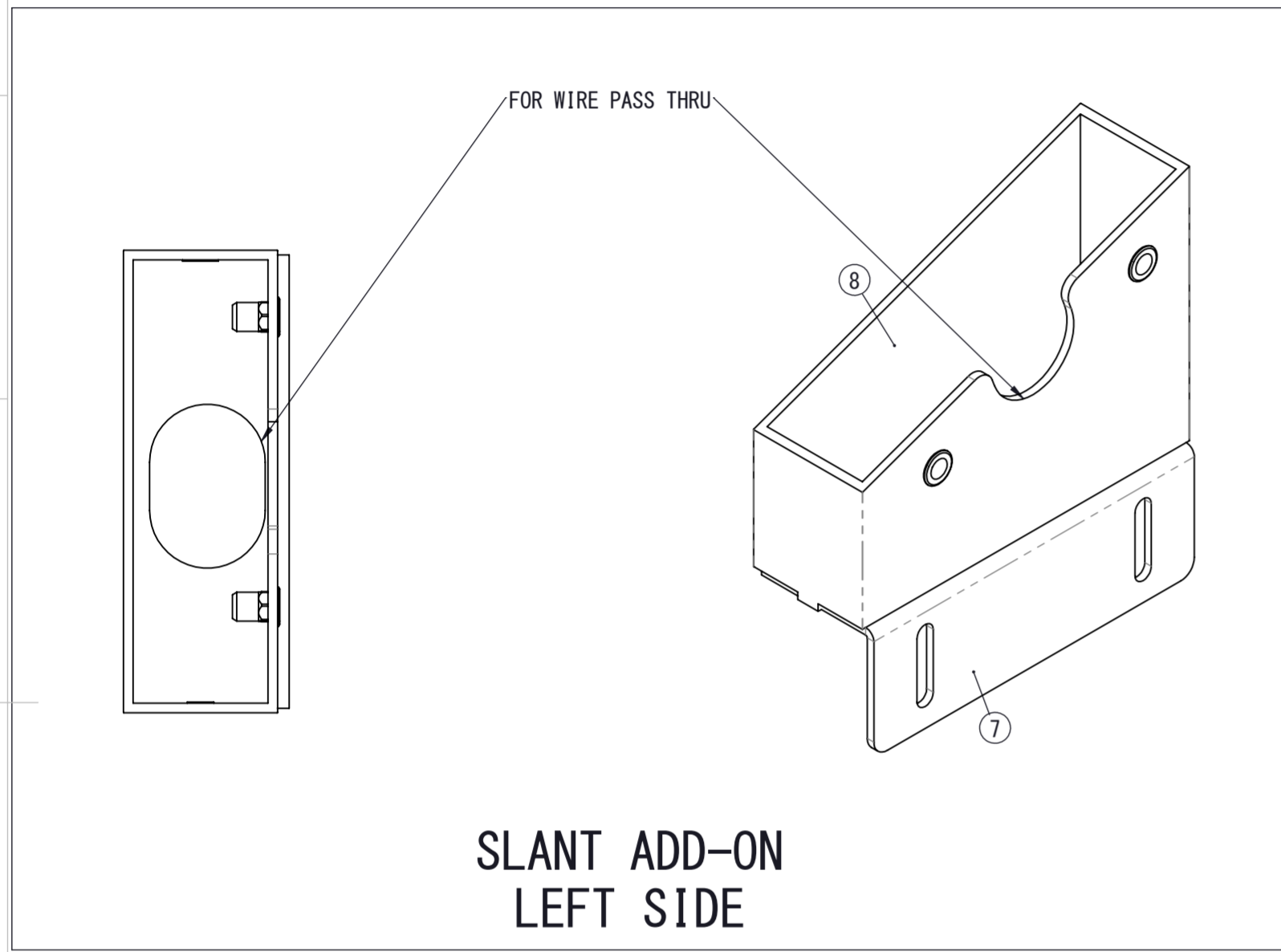

UNLESS OTHERWISE SPECIFIED: DIMENSIONS ARE IN INCHES SURFACE FINISH: TOLERANCES: LINEAR: .01 ANGULAR: .5		FINISH:	DEBUR AND BREAK SHARP EDGES	DO NOT SCALE DRAWING	REVISION
				Digital Touch Systems	
DRAWN:		NAME	SIGNATURE	DATE	TITLE:
CHK'D:					
APP'V'D:					
MFG:					
Q.A.				MATERIAL:	DWG NO. DTS-46-LKN
				WEIGHT:	SCALE: 1:16
					SHEET 3 OF 6

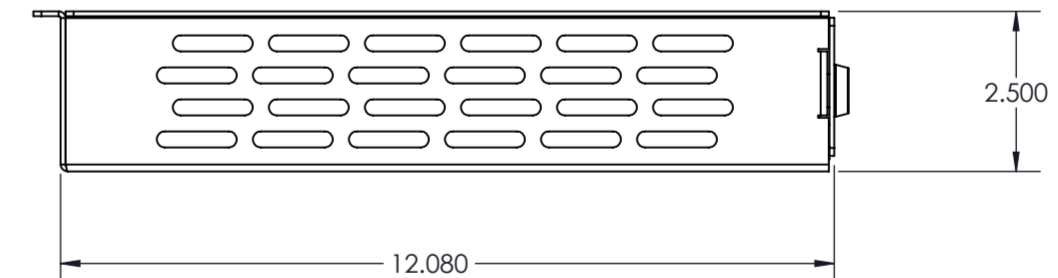
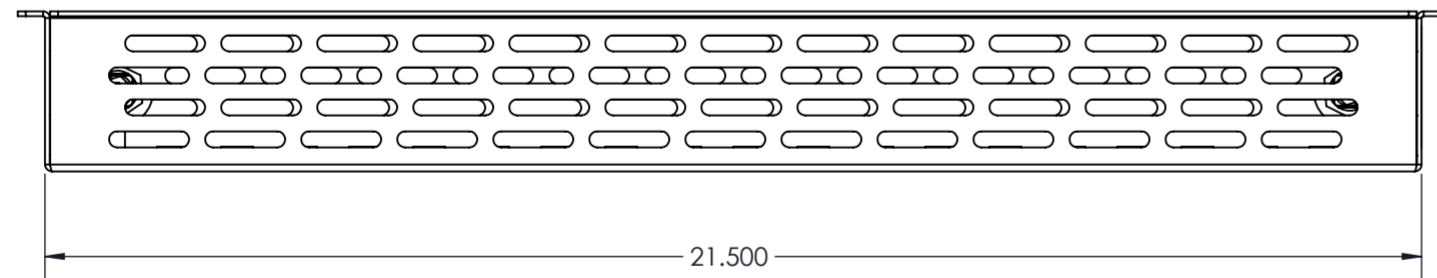
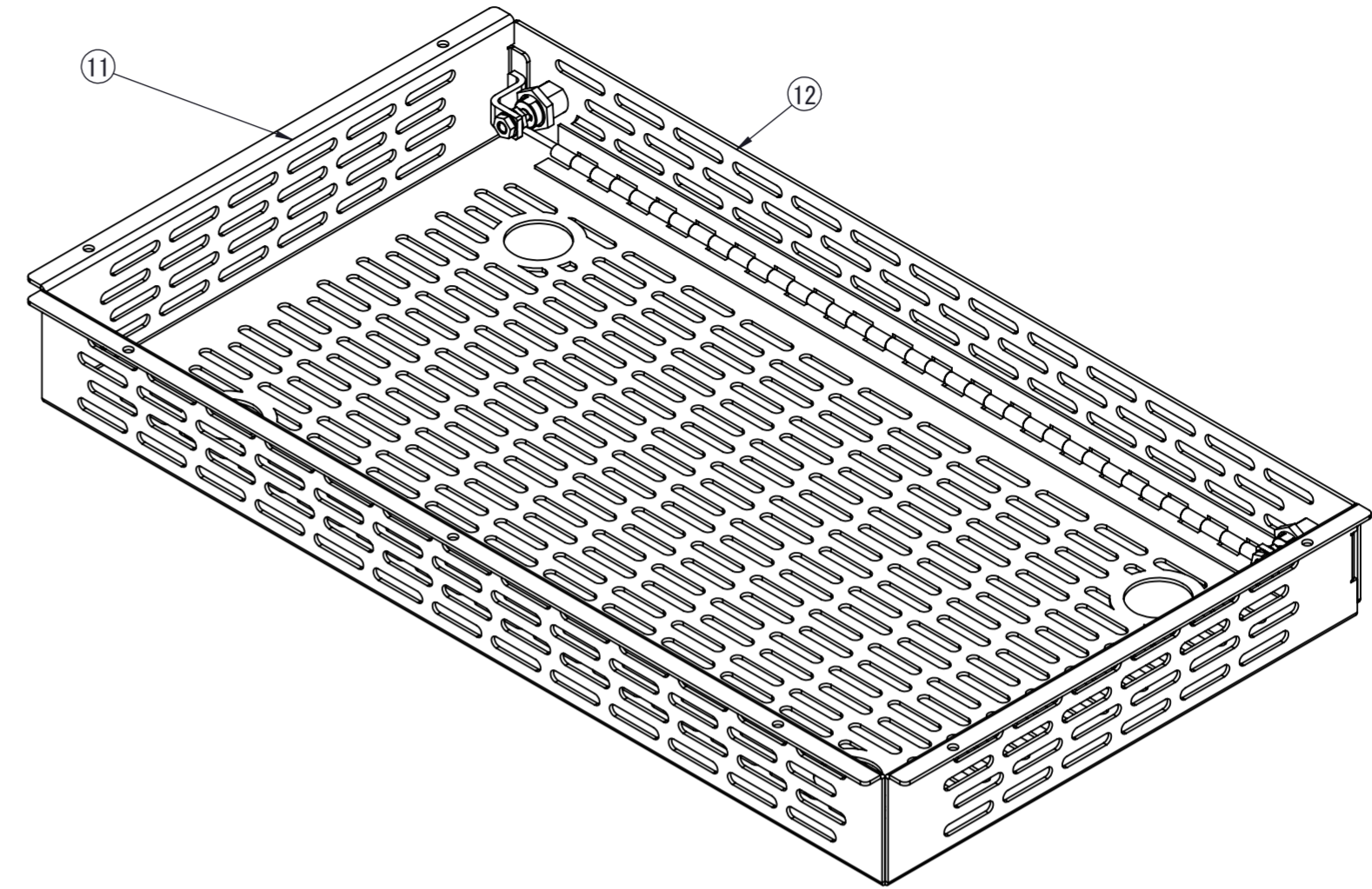
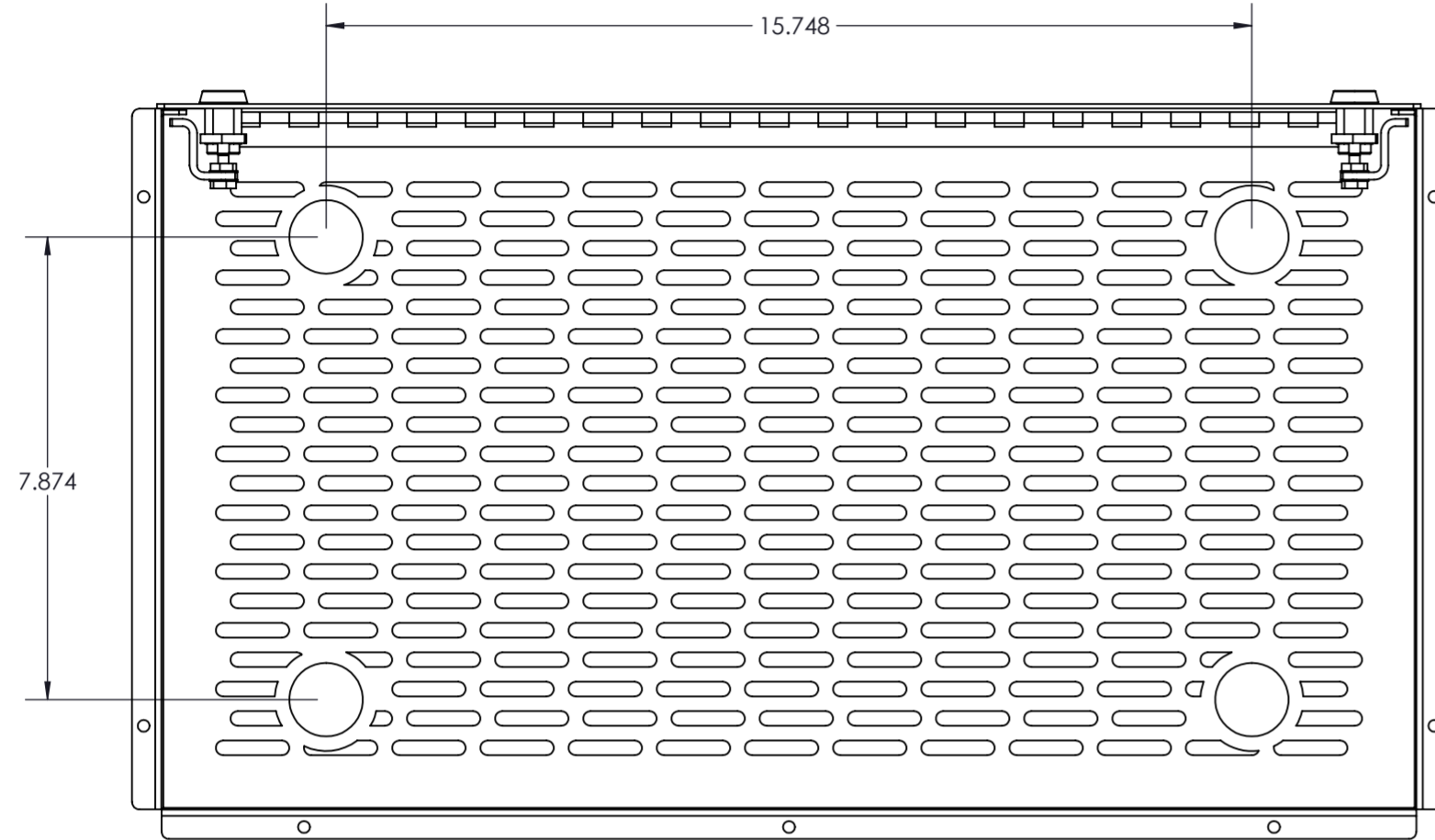

UNLESS OTHERWISE SPECIFIED: DIMENSIONS ARE IN INCHES SURFACE FINISH: TOLERANCES: LINEAR: .01 ANGULAR: .5		FINISH:		DEBUR AND BREAK SHARP EDGES		DO NOT SCALE DRAWING		REVISION	
						Digital Touch Systems			
						TITLE:			
DRAWN:	NAME	SIGNATURE	DATE			DWG NO.		A2	
CHK'D:						DTS-46-LKN			
APP'VD:						SCALE: 1:8		SHEET 4 OF 6	
MFG:						WEIGHT:			
Q.A:						MATERIAL:			

ITEM NO.	PART NUMBER	DESCRIPTION	QTY.
1	3-13BK01	STANDARD DIGITAL TOUCH LOCK	2
2	AEHS8-420-165	1/4-20 HEX RIVNUT	4
3	DTS-46-LKN-BASE	.25" CRS	1
4	DTS-46-LKN-COVER	.06 CRS	1
5	DTS-46-LKN-LEGS	2X6X1/8 AL RECT TUBING	1
6	DTS-46-LKN-PAN	12GA CRS	1
7	DTS-SLT-1	.075 CRS	1
8	DTS-SLT-2	.075 CRS	1
9	SS-032-2ZC	10-32 SS PEM NUT	9
10	SS61015-01	1" SS HINGE	2
17	NEP460-002_ASSEMBLY(191216)	46" SCREEN FOR REFERENCE	1

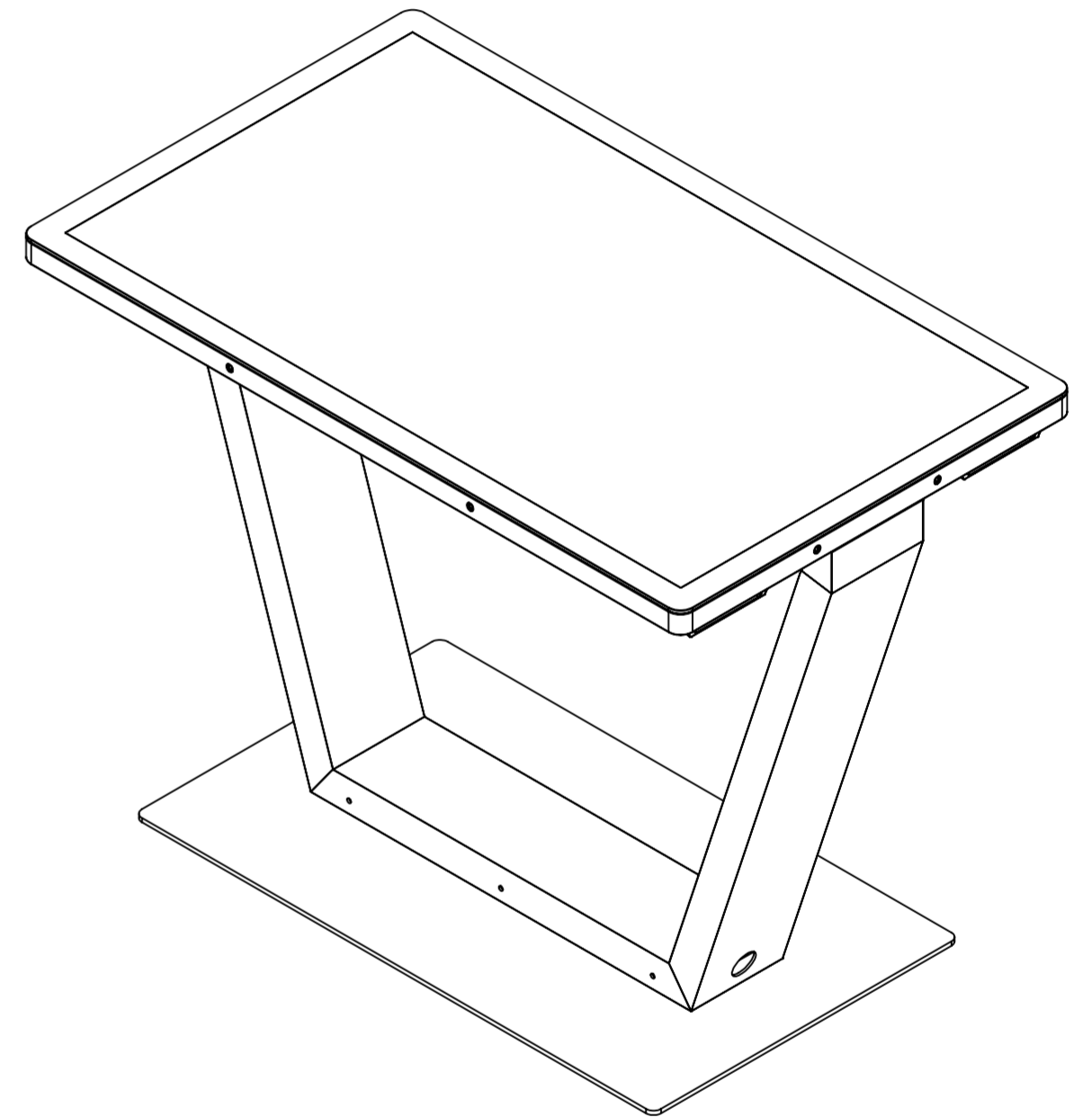
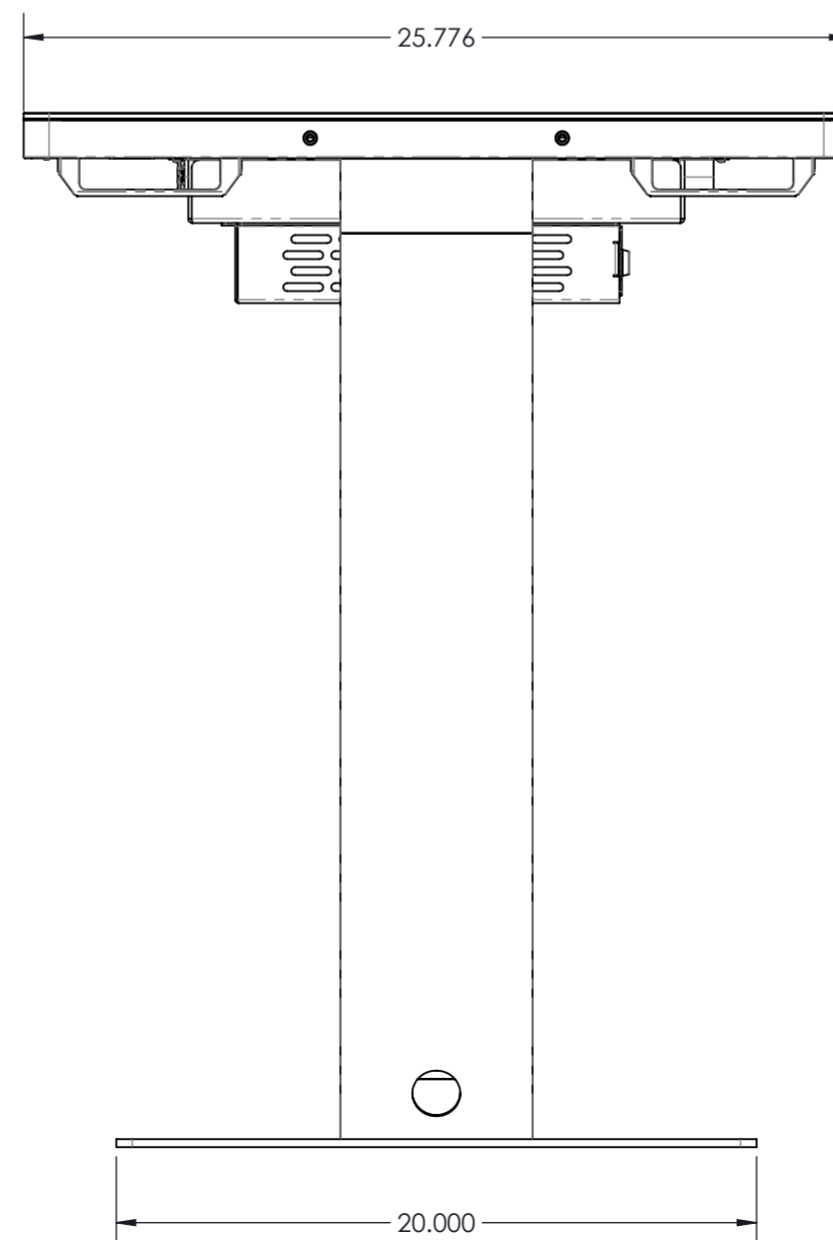
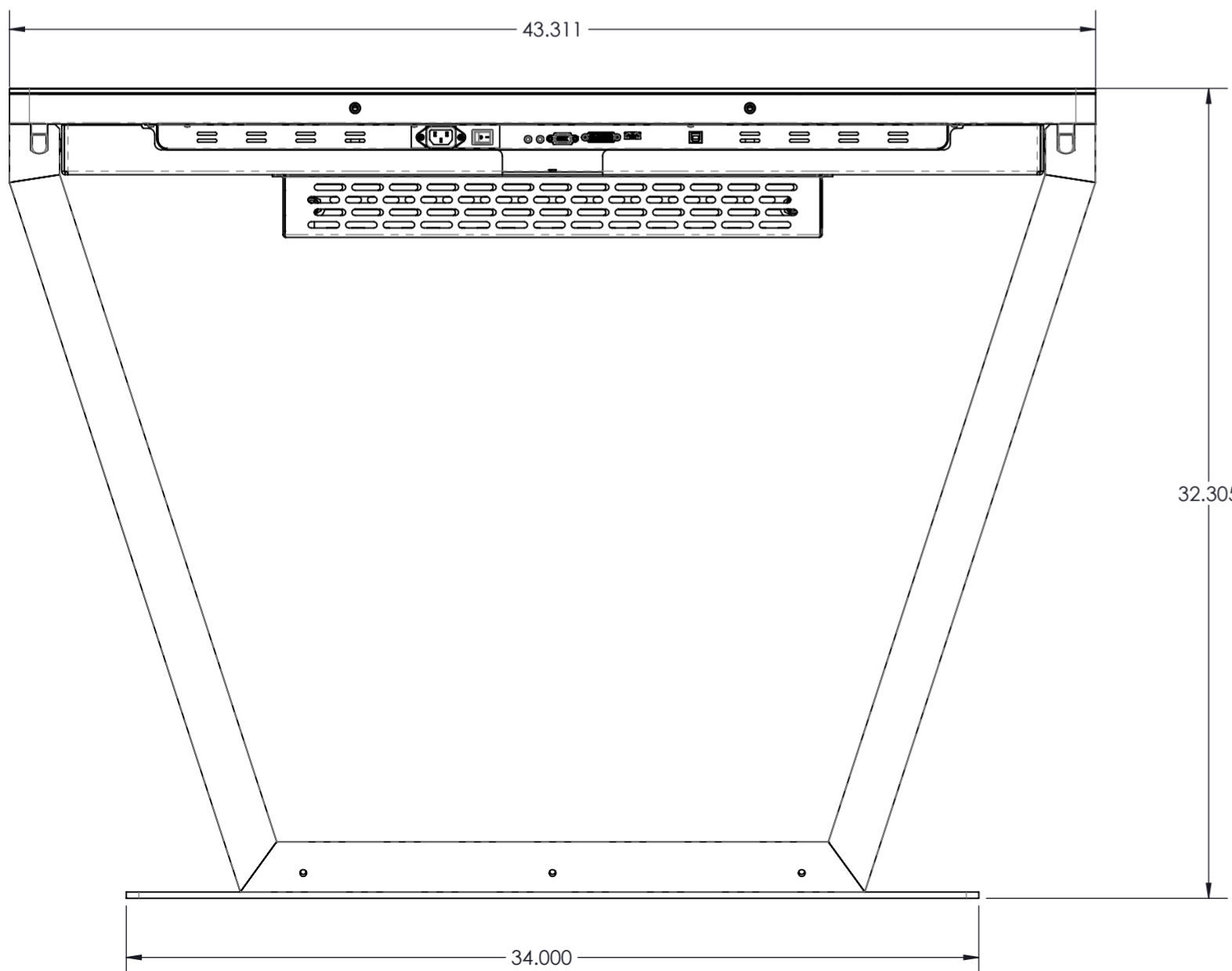
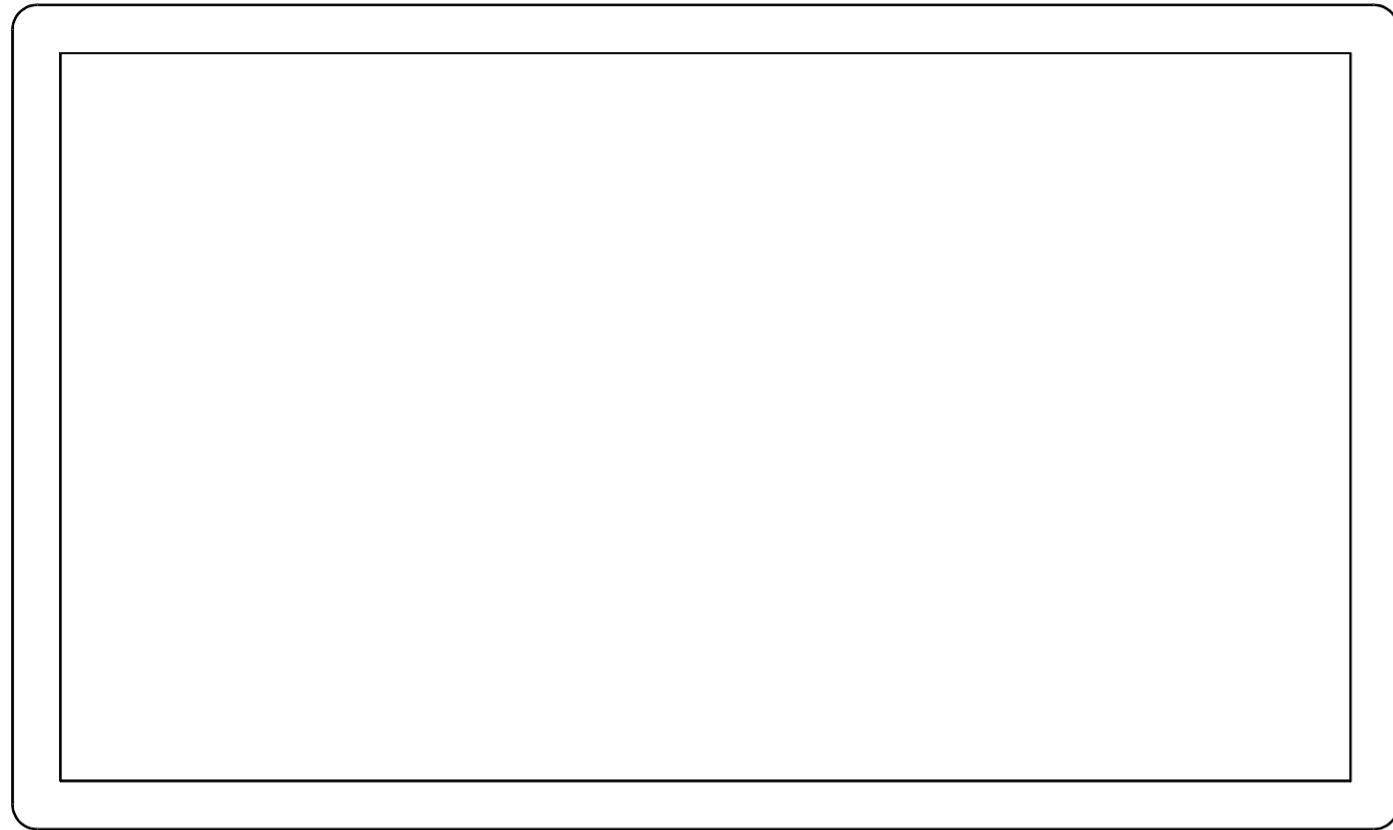

UNLESS OTHERWISE SPECIFIED: DIMENSIONS ARE IN INCHES SURFACE FINISH: TOLERANCES: LINEAR: .01 ANGULAR: .5		FINISH:	DEBUR AND BREAK SHARP EDGES	DO NOT SCALE DRAWING	REVISION
			Digital Touch Systems		
DRAWN	NAME	SIGNATURE	DATE	TITLE:	
CHK'D					
APP'VD					
MFG					
Q.A.				DWG NO.	DTS-46-LKN
				SCALE: 1:16	A2
				WEIGHT:	SHEET 5 OF 6

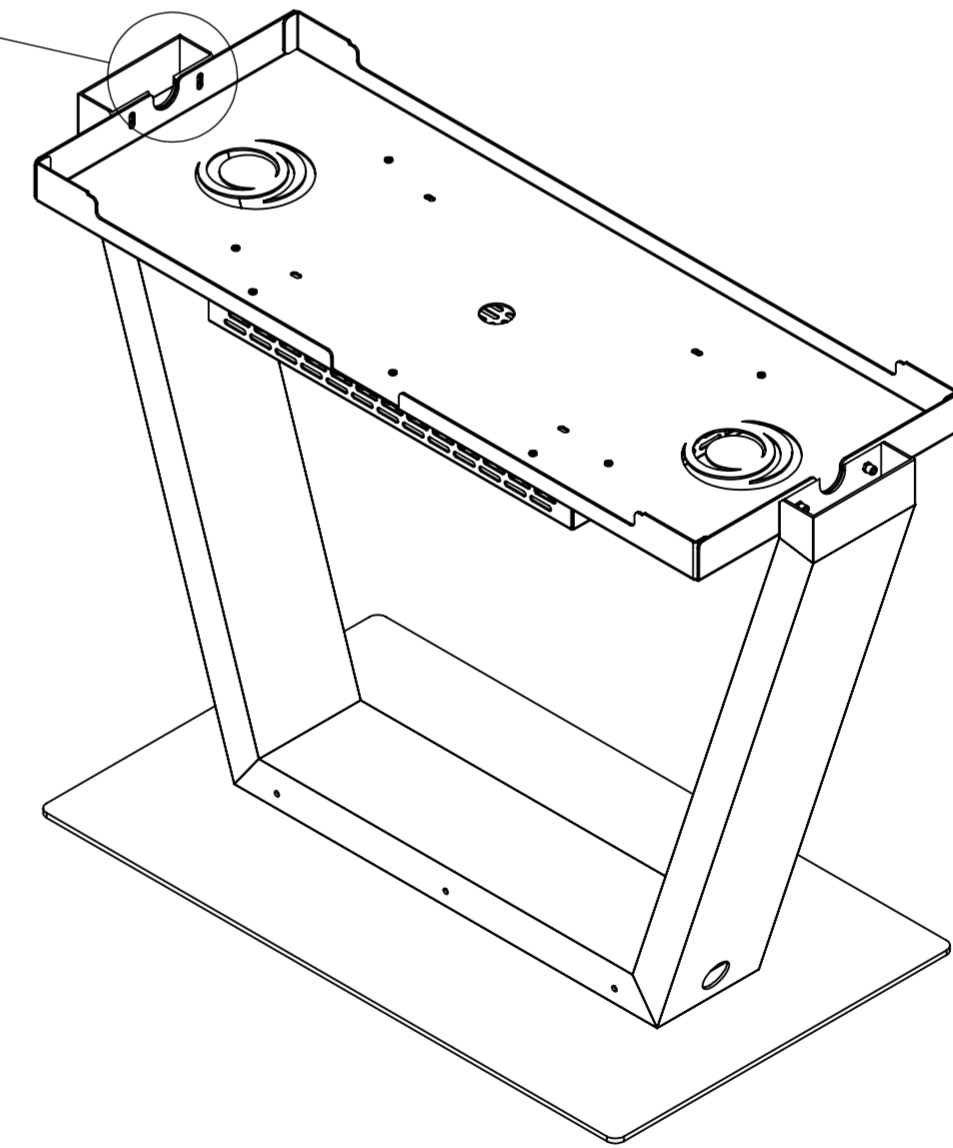
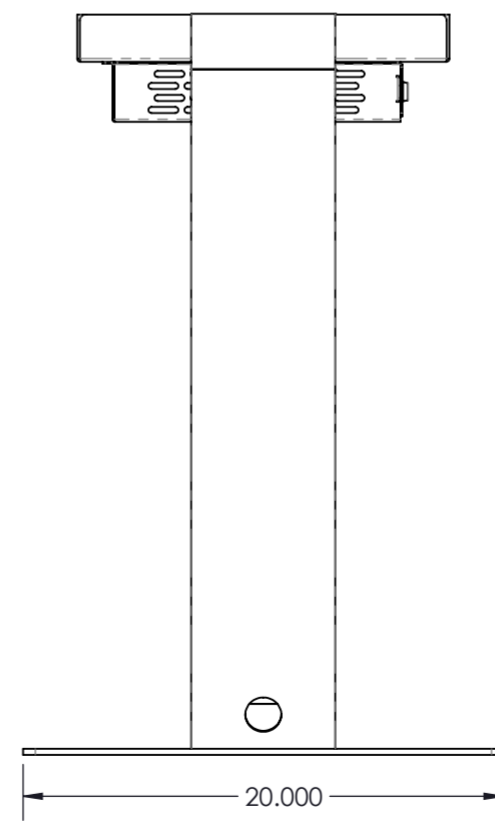
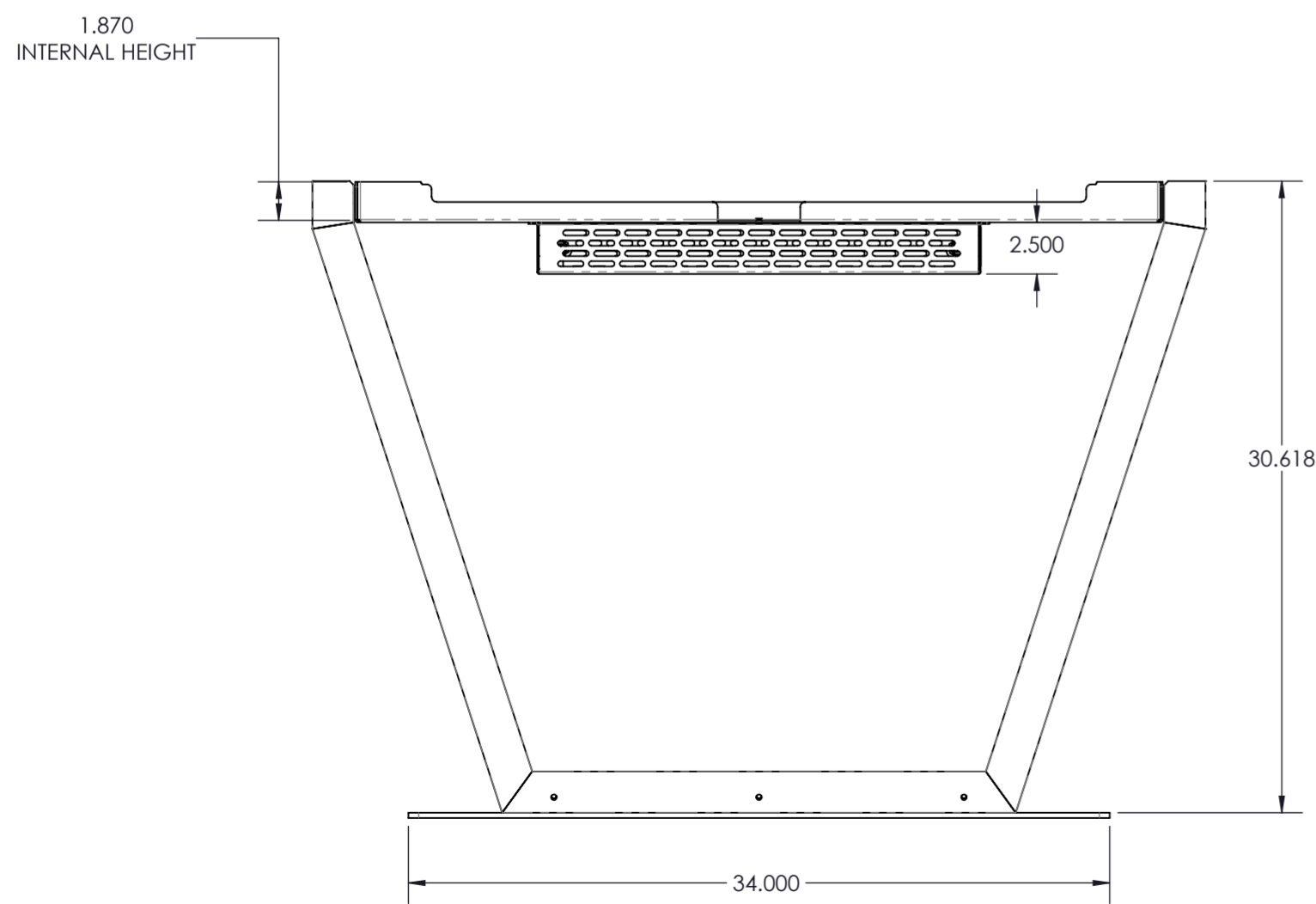
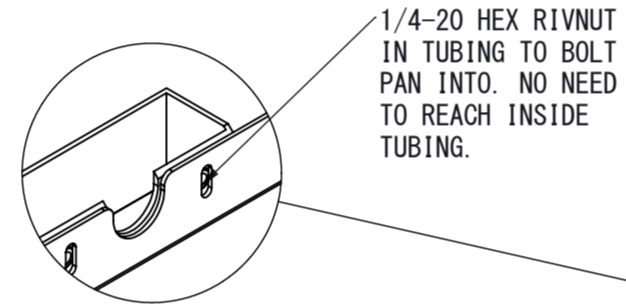
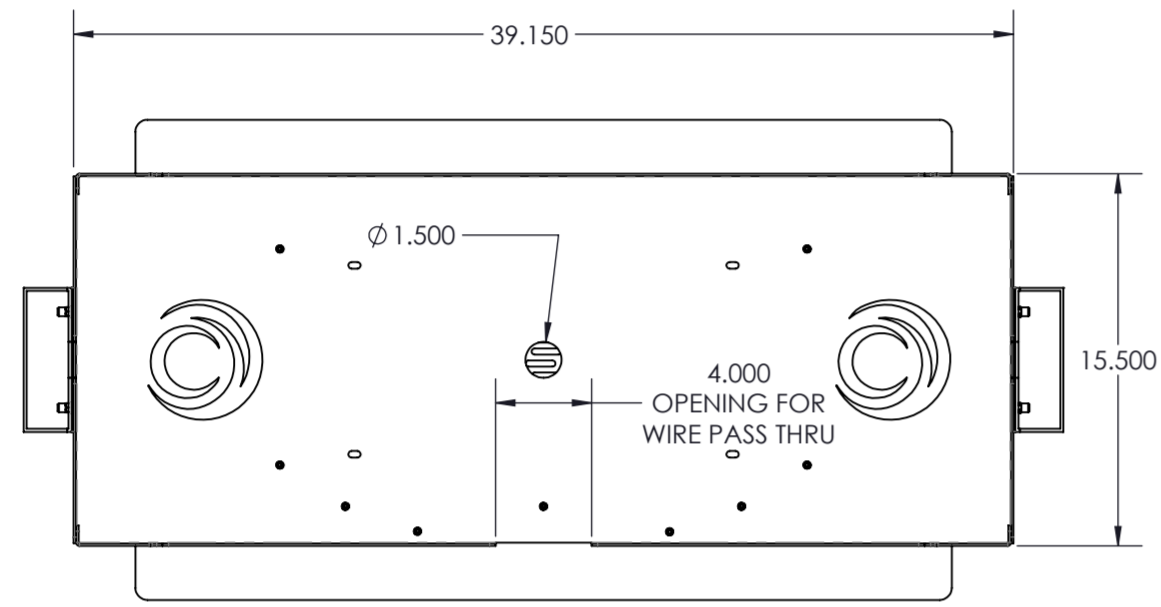

UNLESS OTHERWISE SPECIFIED: DIMENSIONS ARE IN INCHES SURFACE FINISH: TOLERANCES: LINEAR: .01 ANGULAR: .5		FINISH:	DEBUR AND BREAK SHARP EDGES		DO NOT SCALE DRAWING	REVISION
					Digital Touch Systems	
					TITLE:	
DRAWN:	NAME	SIGNATURE	DATE		DWG NO.	DTS-46-LKN
CHK'D:						A2
APP'V'D:						
MFG:						
Q.A.				MATERIAL:		
				WEIGHT:	SCALE: 1:16	SHEET 6 OF 6