

ITEM NO.	PART NUMBER	DESCRIPTION	QTY.
1	20160627-141142-03547594	10-32 SS PEM NUT	9
2	AEHS8-420-165	1/4-20 HEX RIVNUT	8
3	DTS-55-LKN-BASE	.25" CRS	1
4	DTS-55-LKN-COVER	.06 CRS	1
5	DTS-55-LKN-LEGS	2X6X1/8 AL RECT TUBING	1
6	DTS-55-LKN-PAN	12GA CRS	1
7	DTS-55-LKN-SLANT-1	1/8" AL	1
8	DTS-55-LKN-SLANT-2	2X6X1/8 AL RECT TUBING	1
9	DTS-55-LKN-SLANT-3	2X6X1/8 AL RECT TUBING	1
10	DTS-55-LKN-SLANT-4	1/8" AL	1
11	DTS-SLT-1	.075 CRS	1
12	DTS-SLT-2	.075 CRS	1
13	SS61015-01	1" SS HINGE	2
14	3-13BK01	STANDARD DIGITAL TOUCH LOCK	2
21	NEP550-005	CUSTOMER REFERENCED PART	1

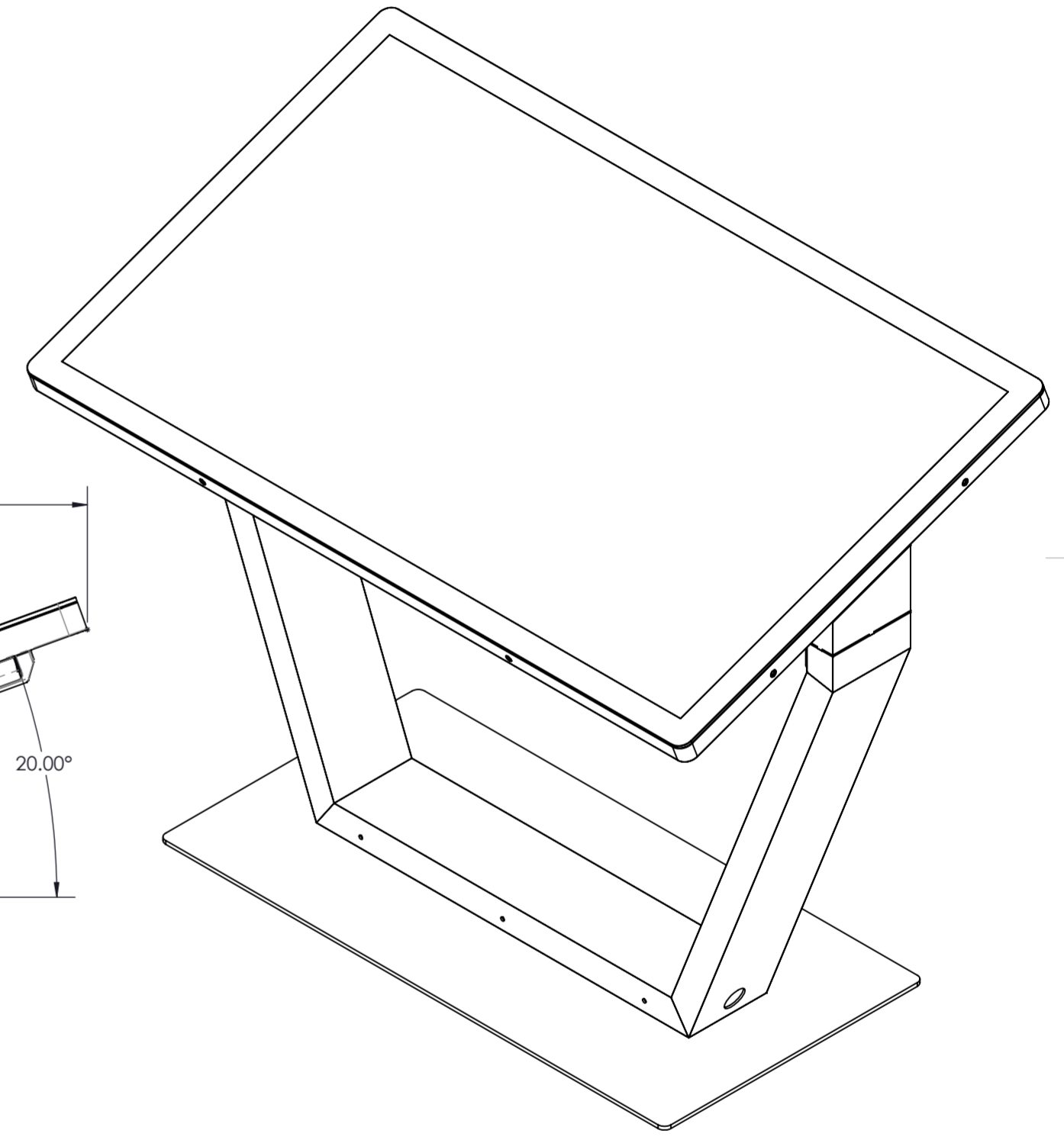
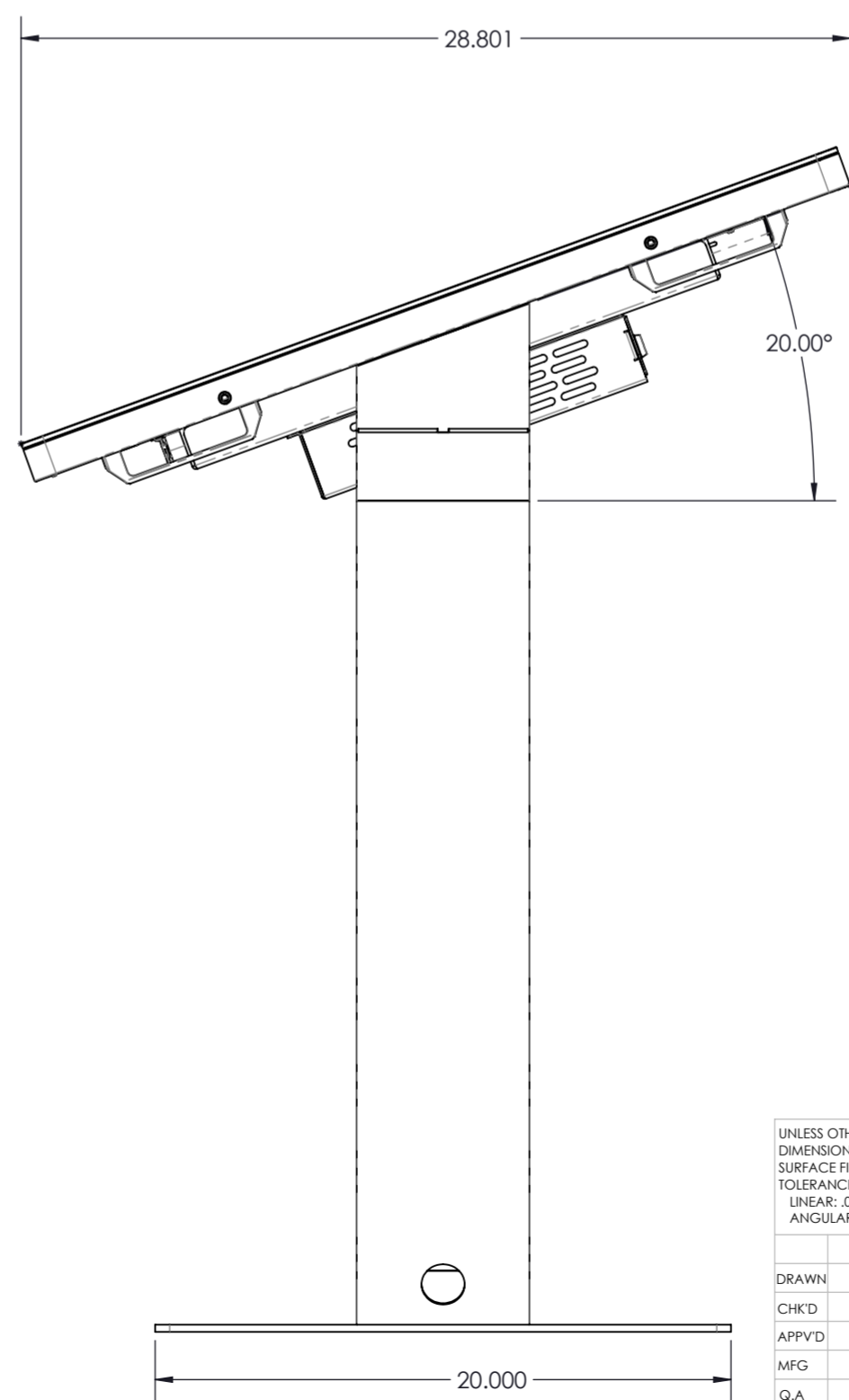
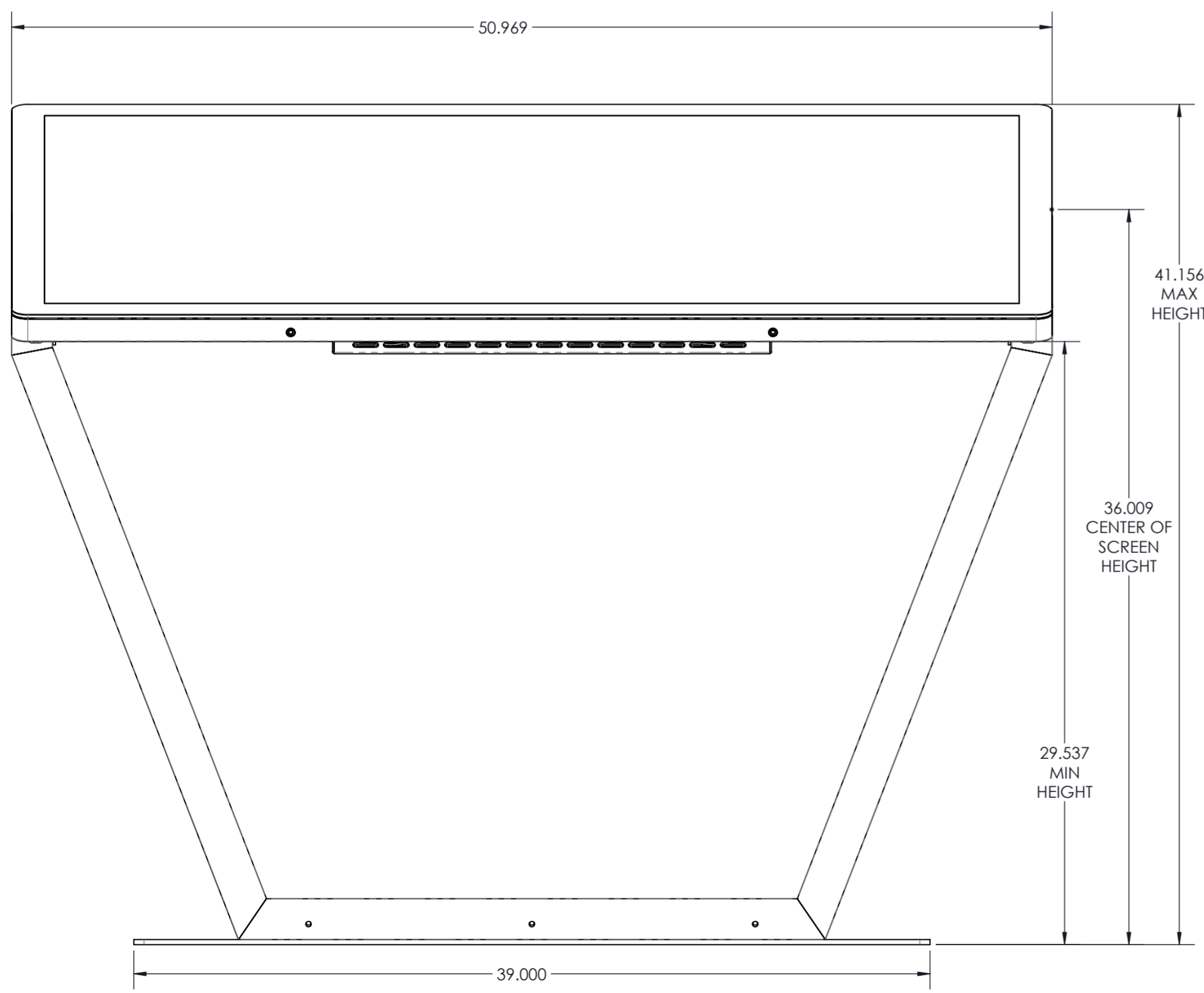
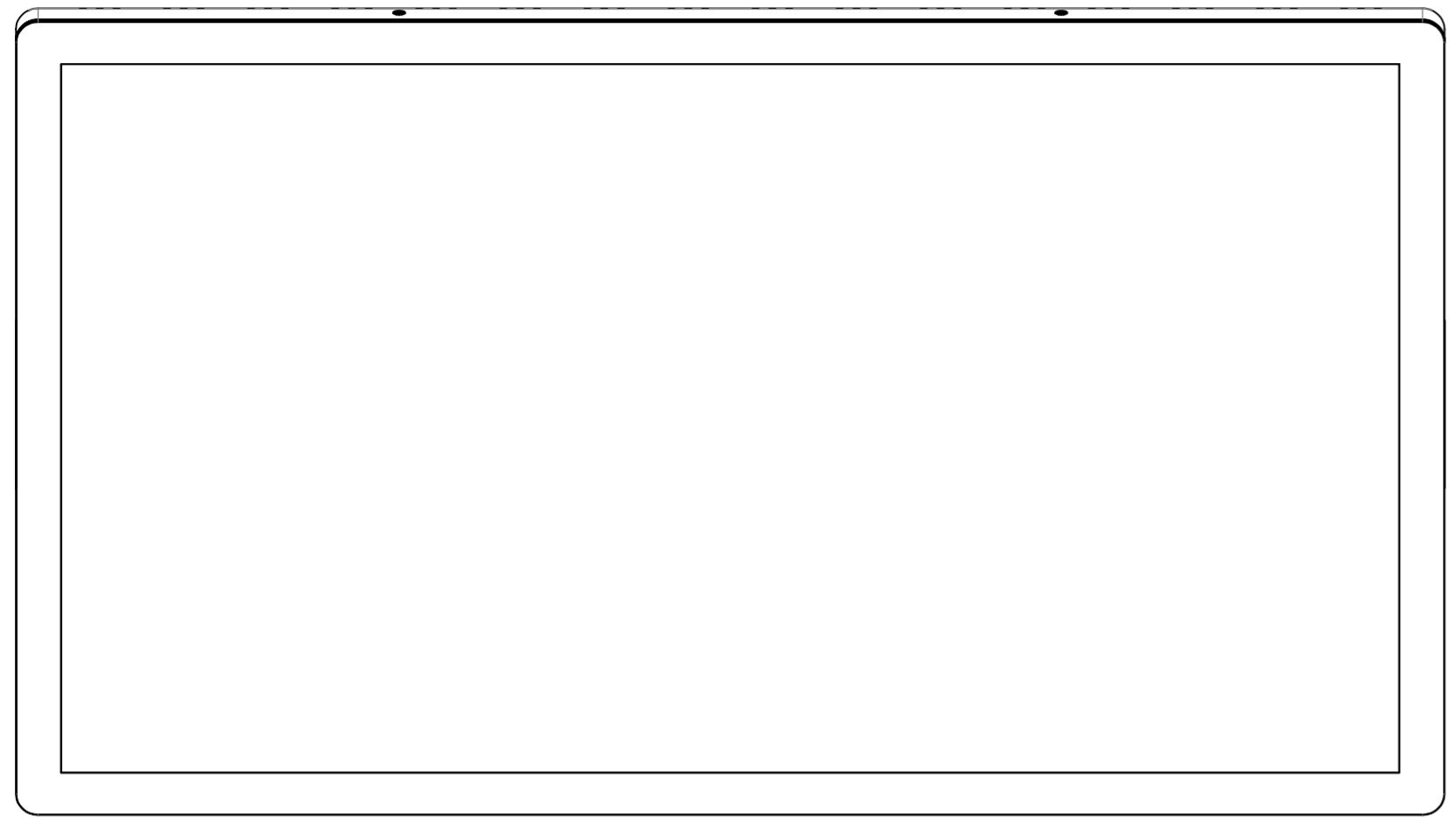

UNLESS OTHERWISE SPECIFIED:
 DIMENSIONS ARE IN INCHES
 SURFACE FINISH:
 TOLERANCES:
 LINEAR: .01
 ANGULAR: .5

FINISH:

DEBUR AND BREAK SHARP EDGES

DO NOT SCALE DRAWING

REVISION

Digital Touch Systems

TITLE:

DRAWN	NAME	SIGNATURE	DATE
CHK'D			
APP'V'D			
MFG			
Q.A.			

MATERIAL:

WEIGHT:

DWG NO. **DTS-55-LKN**

SCALE: 1:16

SHEET 1 OF 6

A2

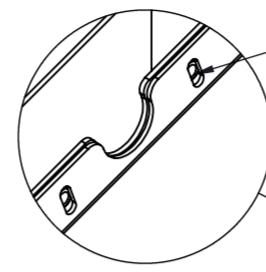

1/4-20 HEX RIVNUT
IN TUBING TO BOLT
PAN INTO. NO NEED
TO REACH INSIDE
TUBING.

DETAIL C
SCALE 1 : 4

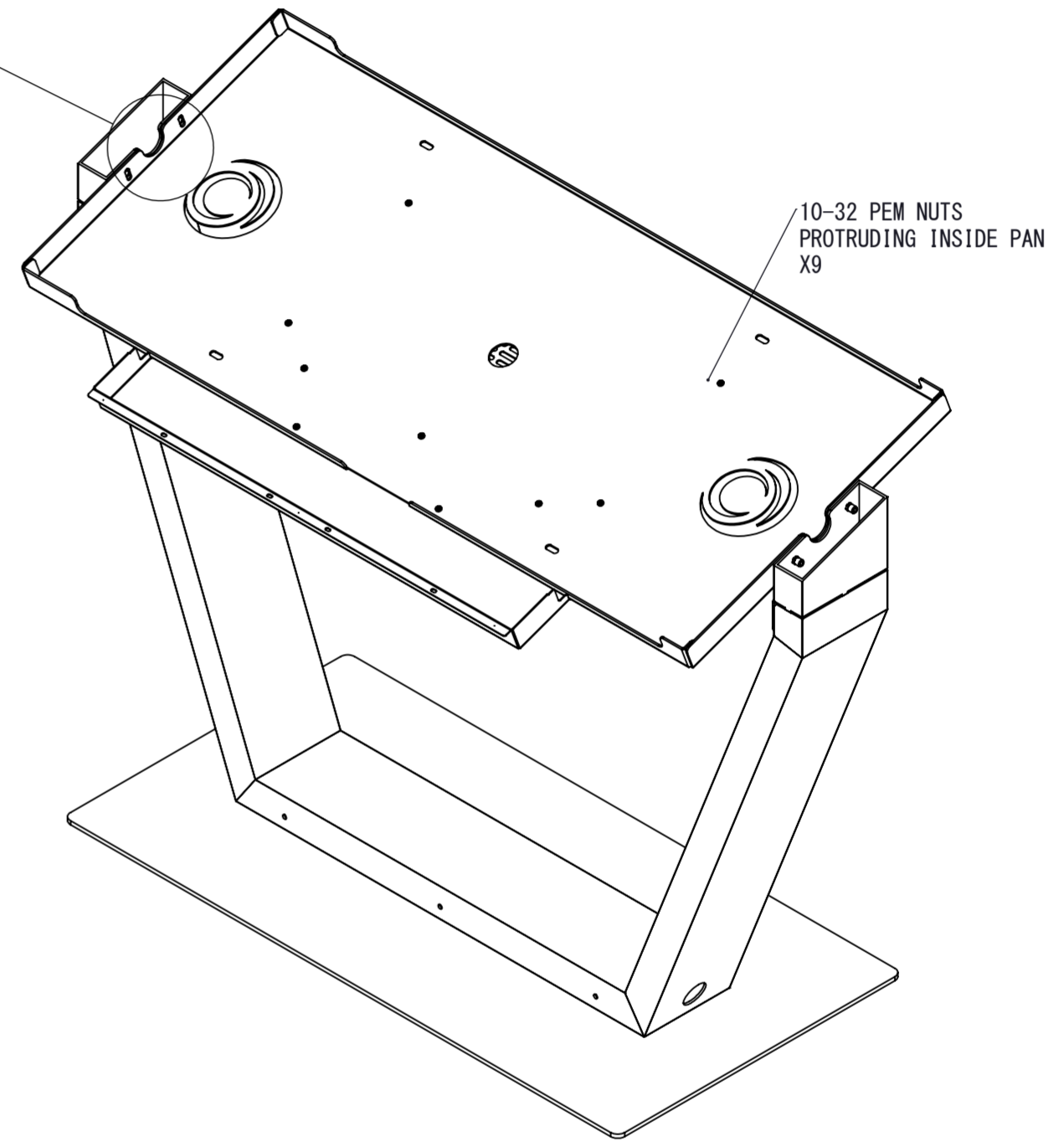
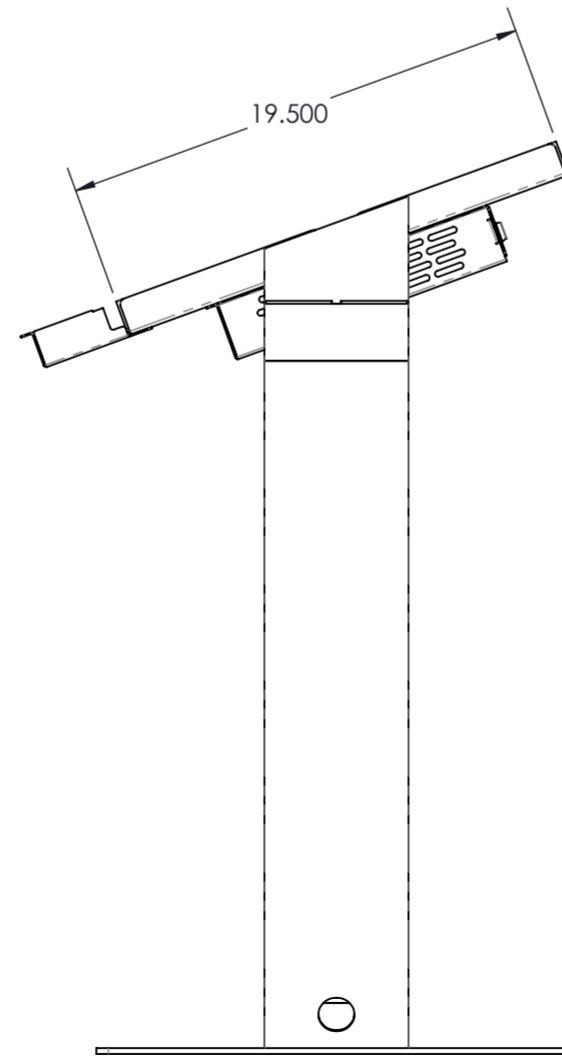
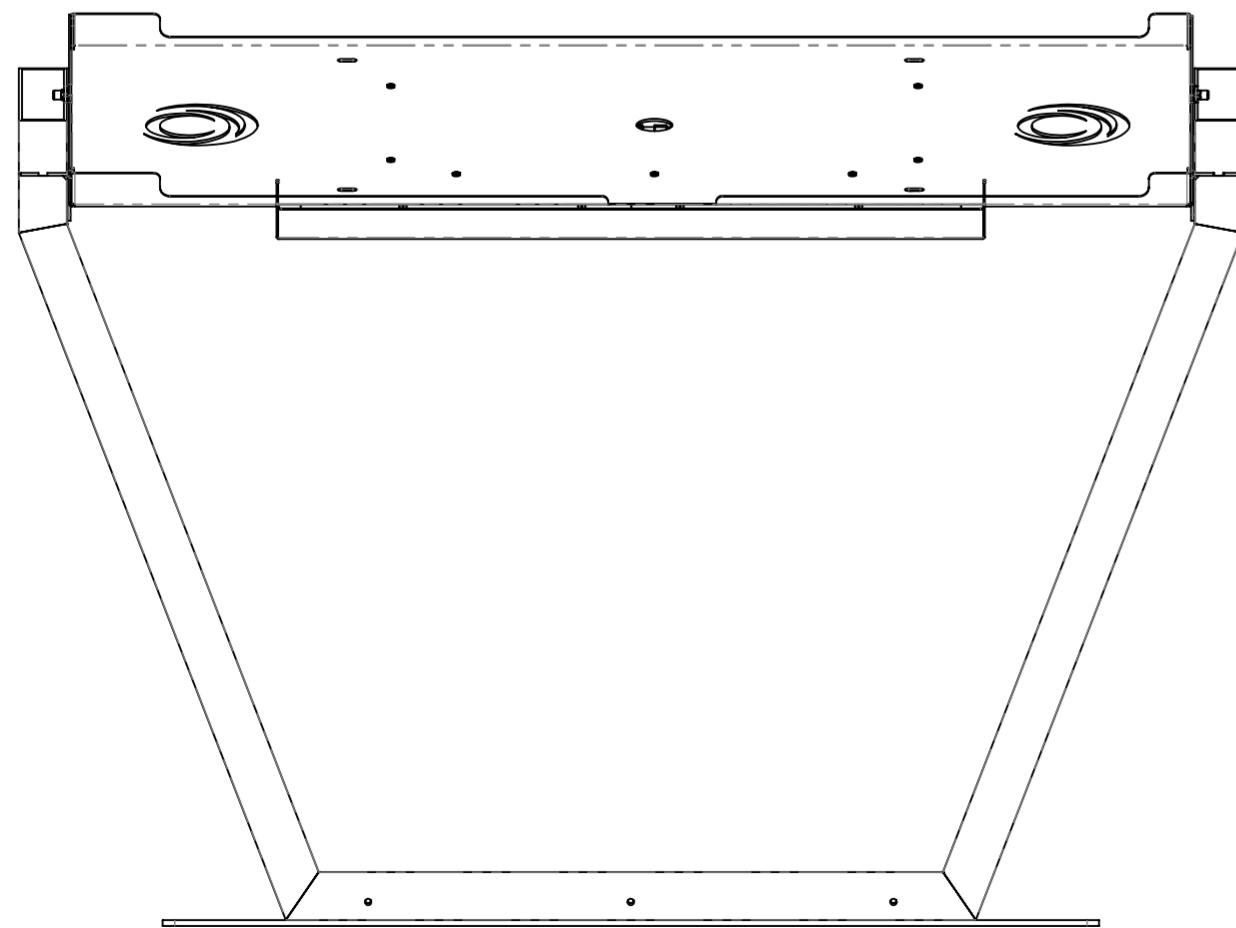
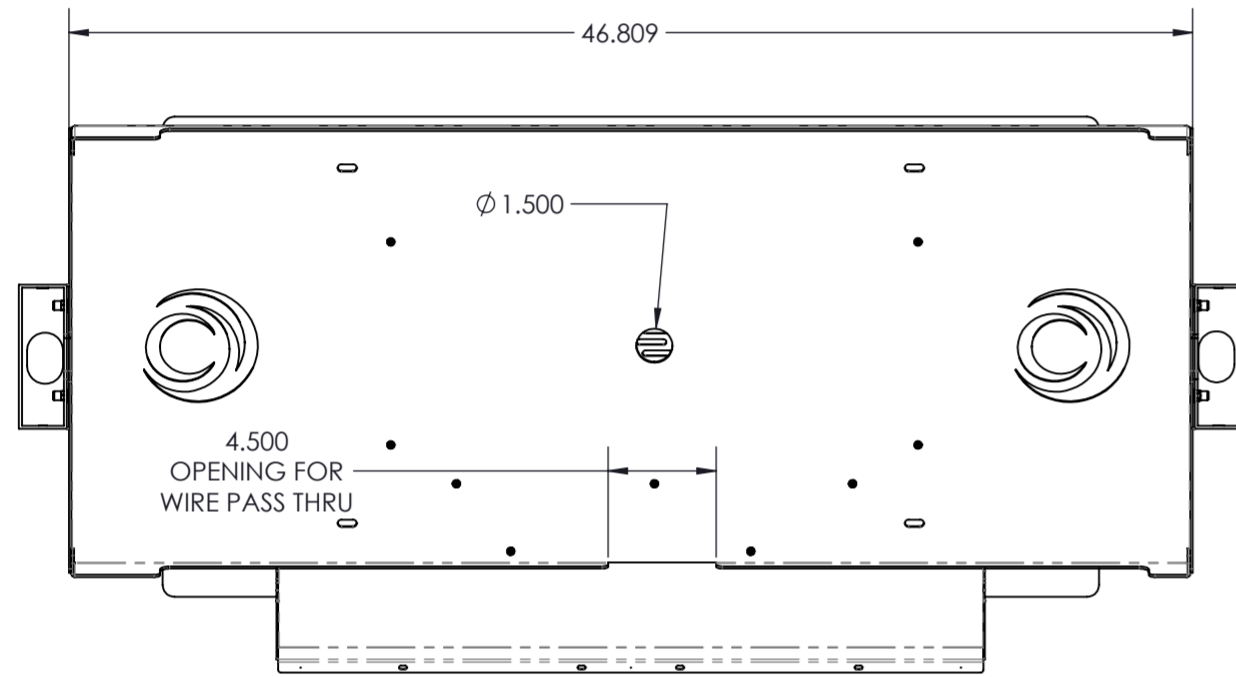

UNLESS OTHERWISE SPECIFIED: DIMENSIONS ARE IN INCHES SURFACE FINISH: TOLERANCES: LINEAR: .01 ANGULAR: .5		FINISH:	DEBUR AND BREAK SHARP EDGES		DO NOT SCALE DRAWING	REVISION
					Digital Touch Systems	
					TITLE:	
DRAWN:	NAME	SIGNATURE	DATE			
CHK'D:						
APP'V'D:						
MFG:						
Q.A.				MATERIAL:	DWG NO.	DTS-55-LKN
				WEIGHT:	SCALE: 1:16	A2
					SHEET 2 OF 6	

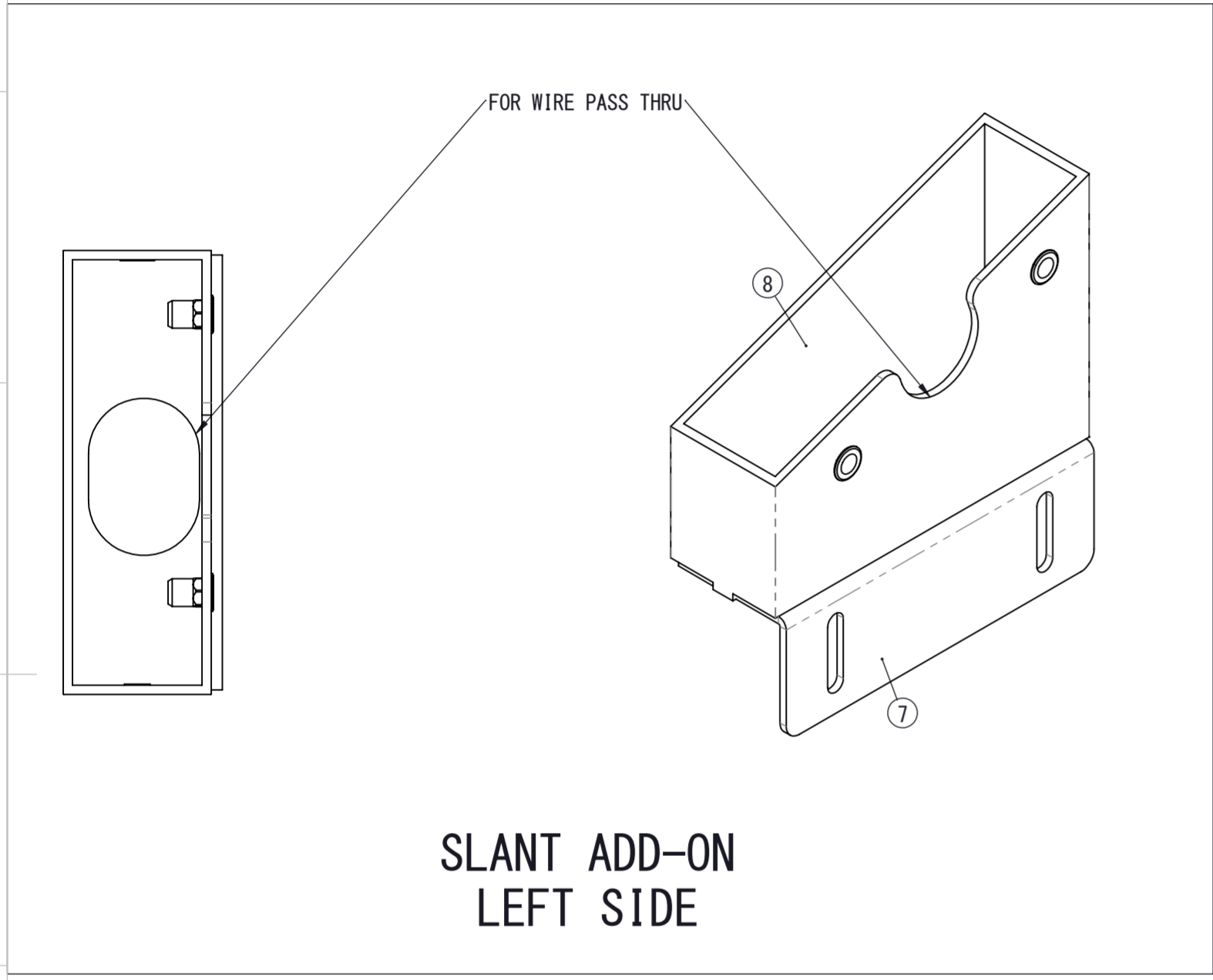

**SLANT ADD-ON
LEFT SIDE**

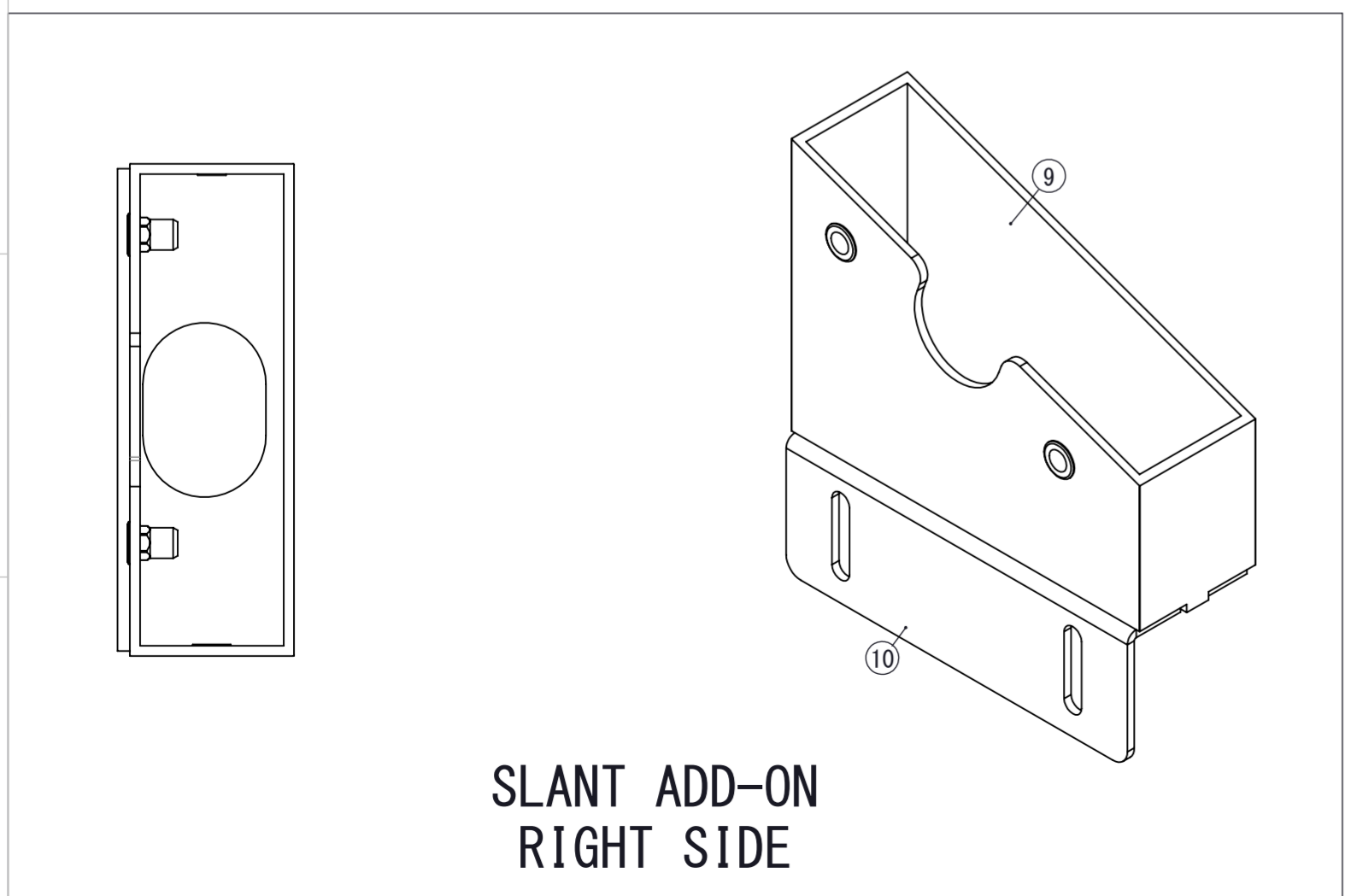

**SLANT ADD-ON
RIGHT SIDE**

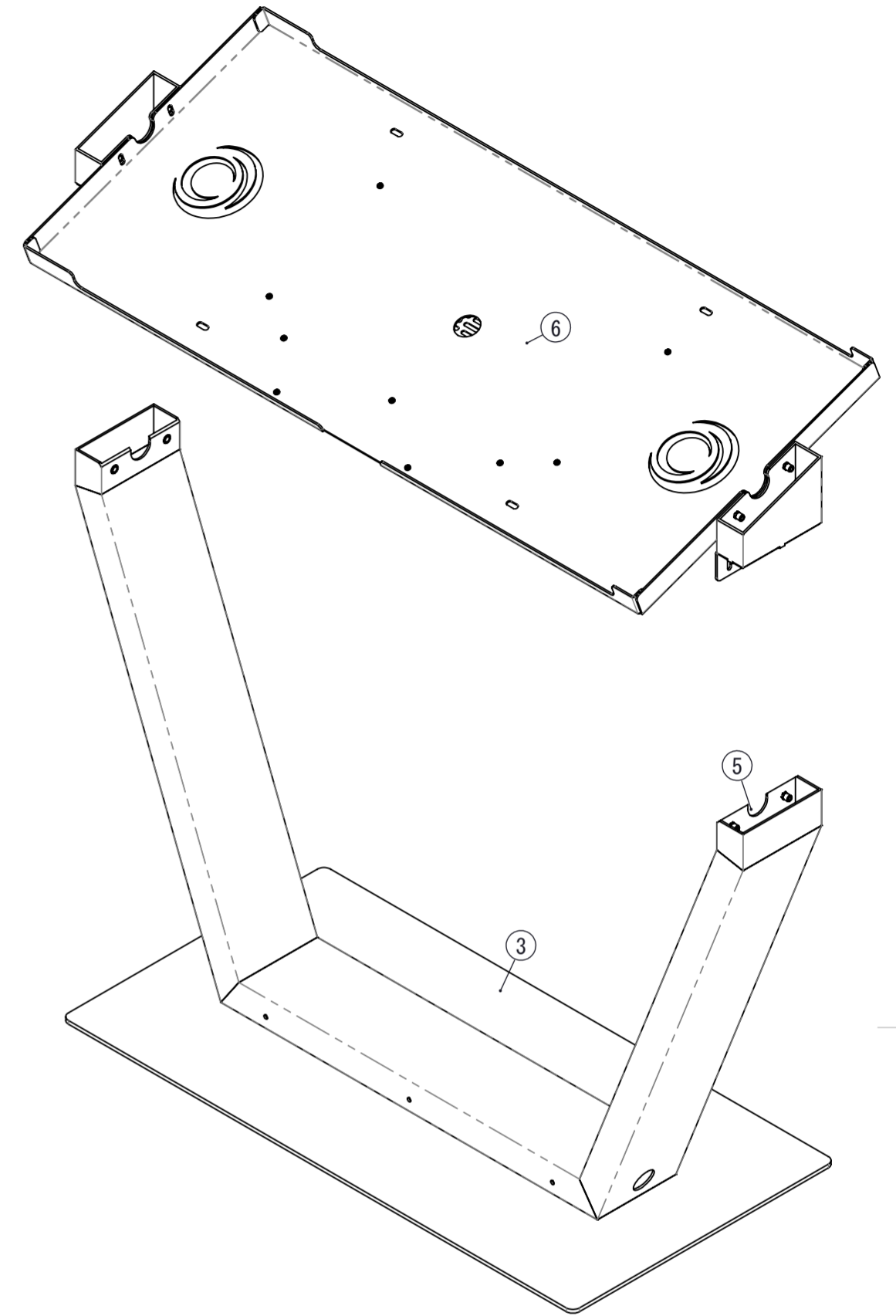
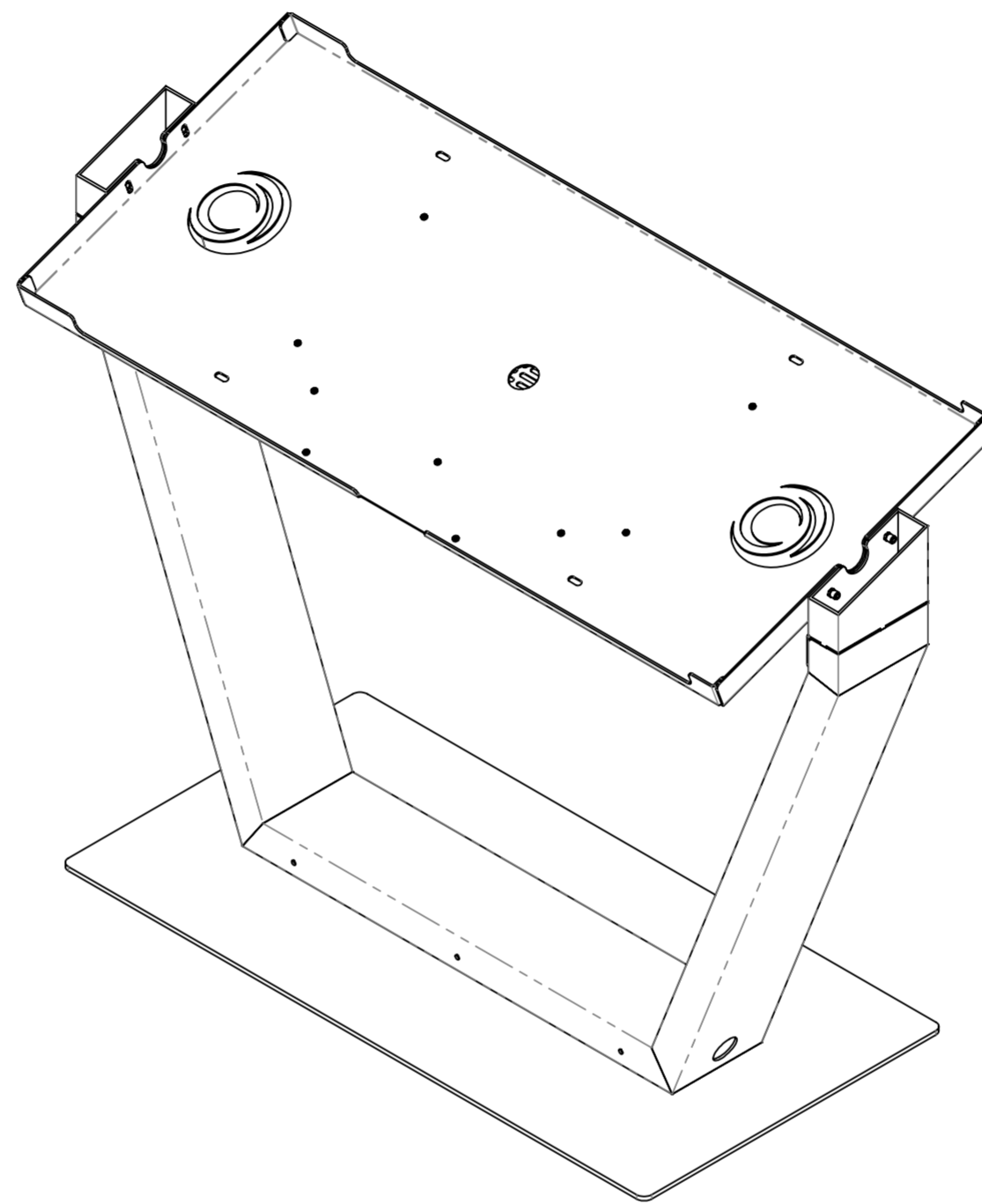

UNLESS OTHERWISE SPECIFIED: DIMENSIONS ARE IN INCHES SURFACE FINISH: TOLERANCES: LINEAR: .01 ANGULAR: .5		FINISH:	DEBUR AND BREAK SHARP EDGES	DO NOT SCALE DRAWING	REVISION
				Digital Touch Systems	
				TITLE:	
DRAWN:	NAME	SIGNATURE	DATE		
CHK'D:					
APP'V'D:					
MFG:					
Q.A.				MATERIAL:	DWG NO. DTS-55-LKN A2
				WEIGHT:	SCALE: 1:16 SHEET 3 OF 6

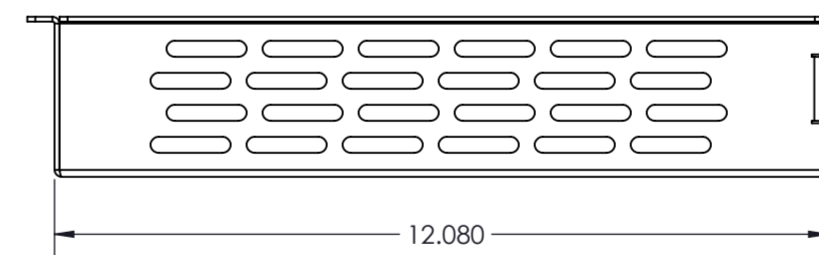
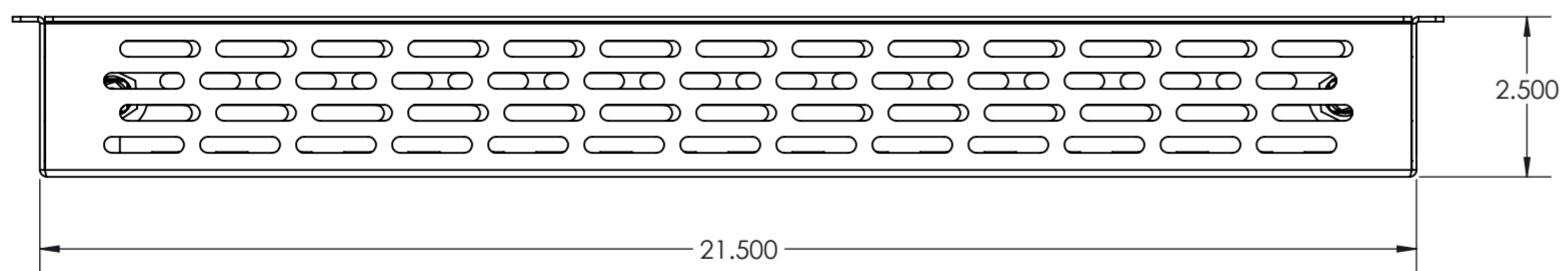
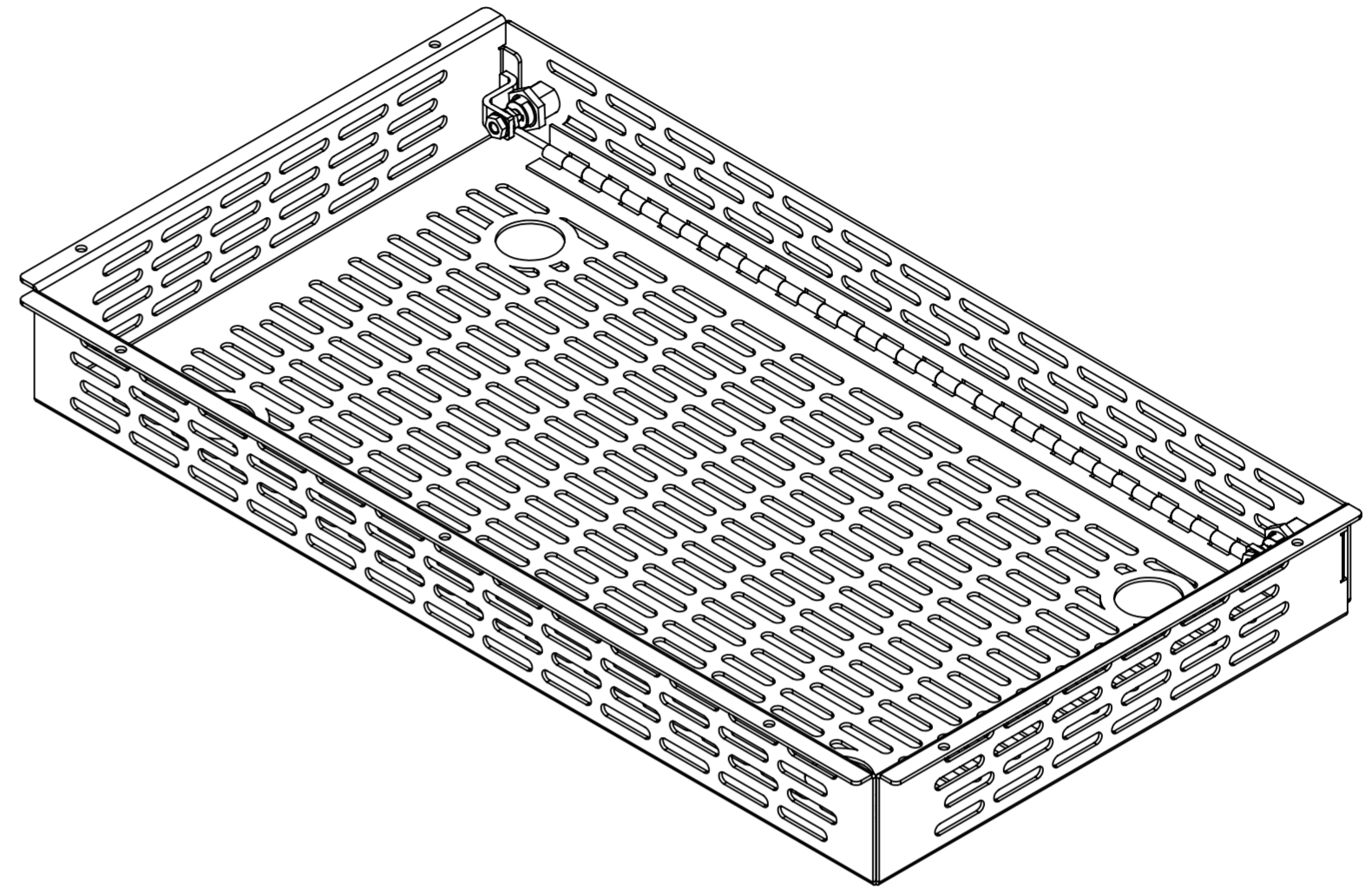
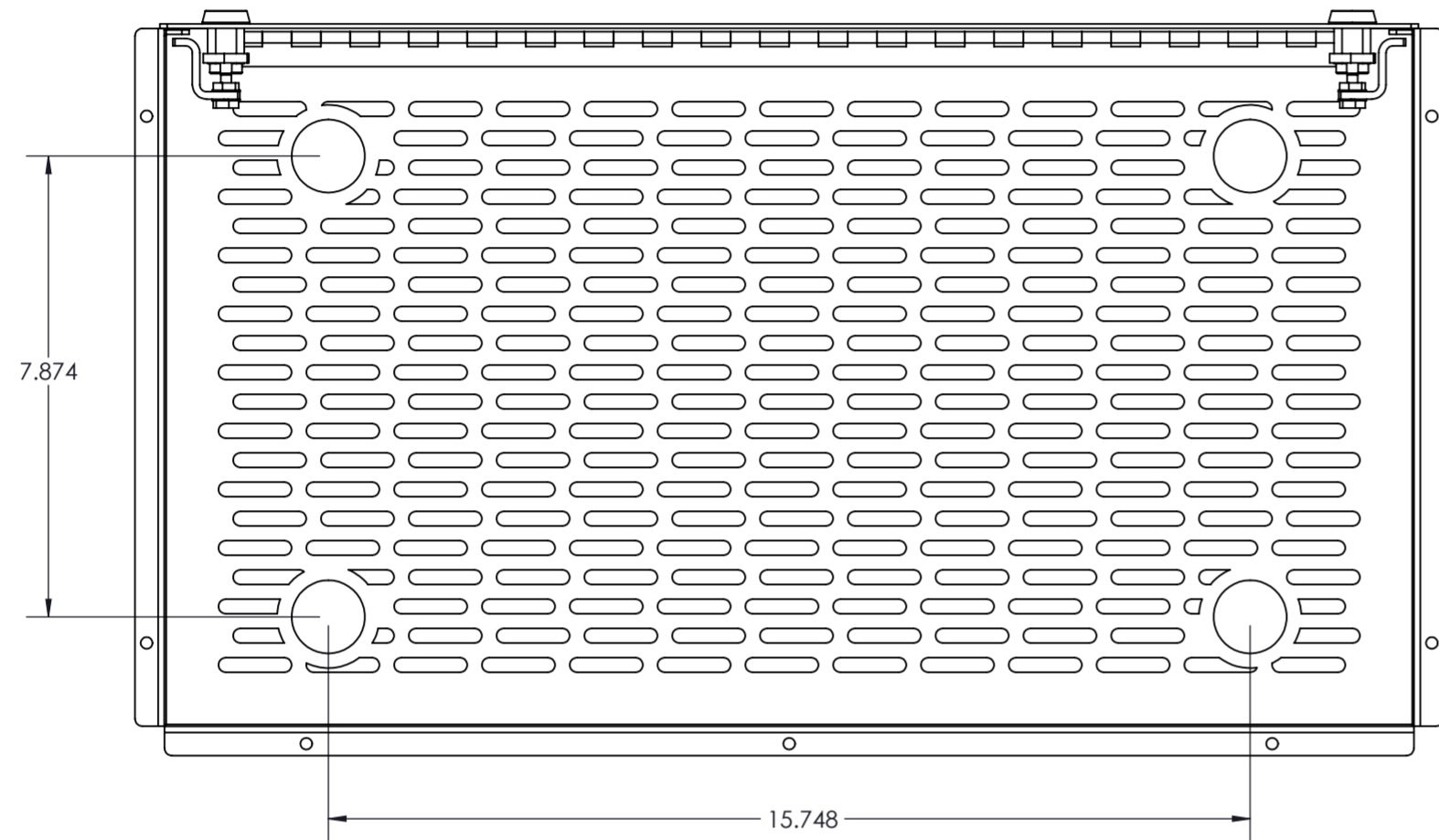

UNLESS OTHERWISE SPECIFIED: DIMENSIONS ARE IN INCHES SURFACE FINISH: TOLERANCES: LINEAR: .01 ANGULAR: .5		FINISH:	DEBUR AND BREAK SHARP EDGES		DO NOT SCALE DRAWING	REVISION
					Digital Touch Systems	
					TITLE:	
DRAWN:	NAME	SIGNATURE	DATE			
CHK'D:						
APP'V'D:						
MFG:						
Q.A.				MATERIAL:	DWG NO.	DTS-55-LKN
				WEIGHT:	SCALE: 1:8	A2
					SHEET 4 OF 6	

ITEM NO.	PART NUMBER	DESCRIPTION	QTY.
1	3-13BK01	STANDARD DIGITAL TOUCH LOCK	2
2	20160627-141142-03547594	10-32 SS PEM NUT	9
3	AEHS8-420-165	1/4-20 HEX RIVNUT	4
4	DTS-55-LKN-BASE	.25" CRS	1
5	DTS-55-LKN-COVER	.06 CRS	1
6	DTS-55-LKN-LEGS	2X6X1/8 AL RECT TUBING	1
7	DTS-55-LKN-PAN	12GA CRS	1
8	DTS-SLT-1	.075 CRS	1
9	DTS-SLT-2	.075 CRS	1
10	SS61015-01	1" SS HINGE	2
17	NEP550-005	CUSTOMER REFERENCED PART	1

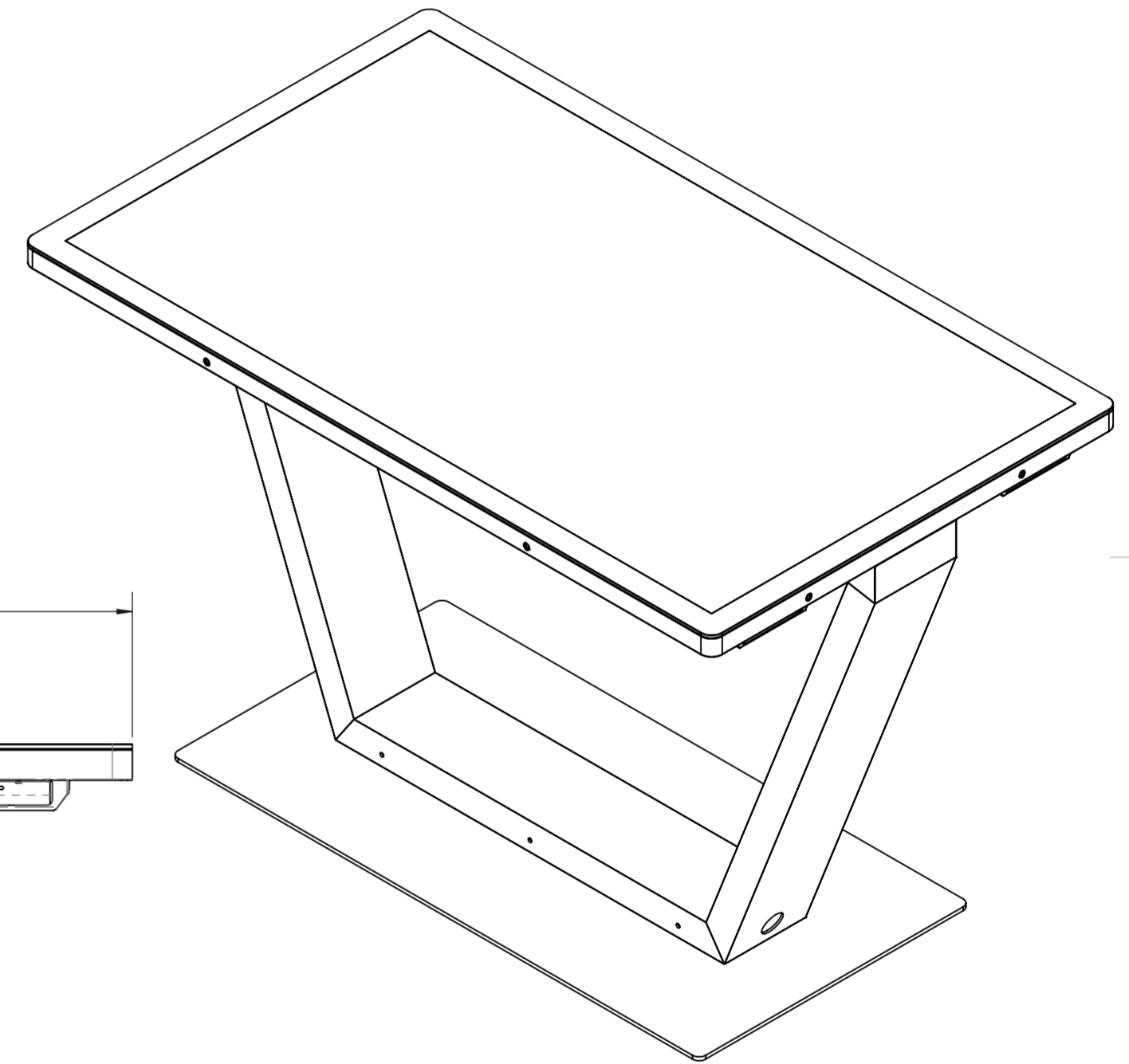
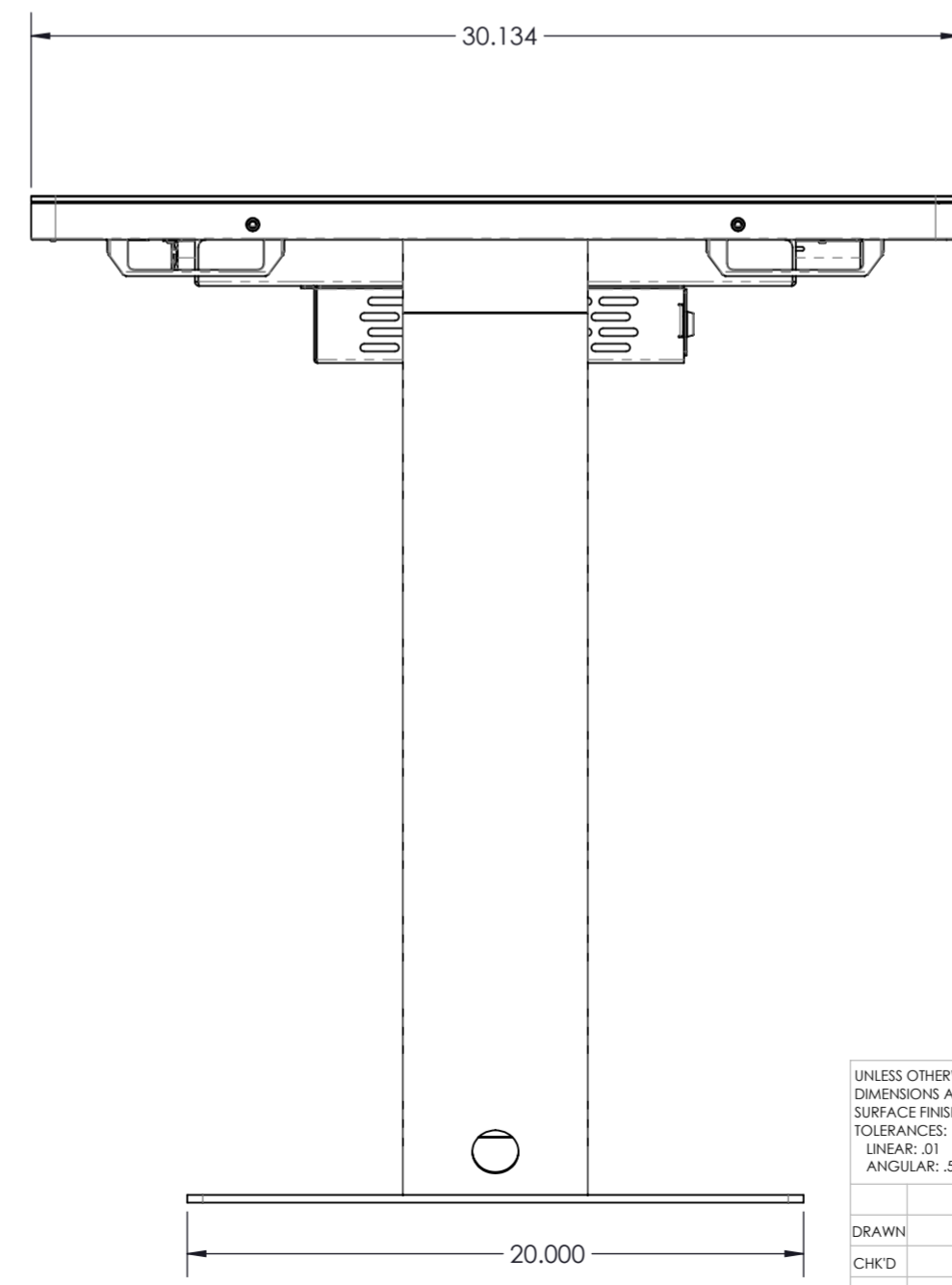
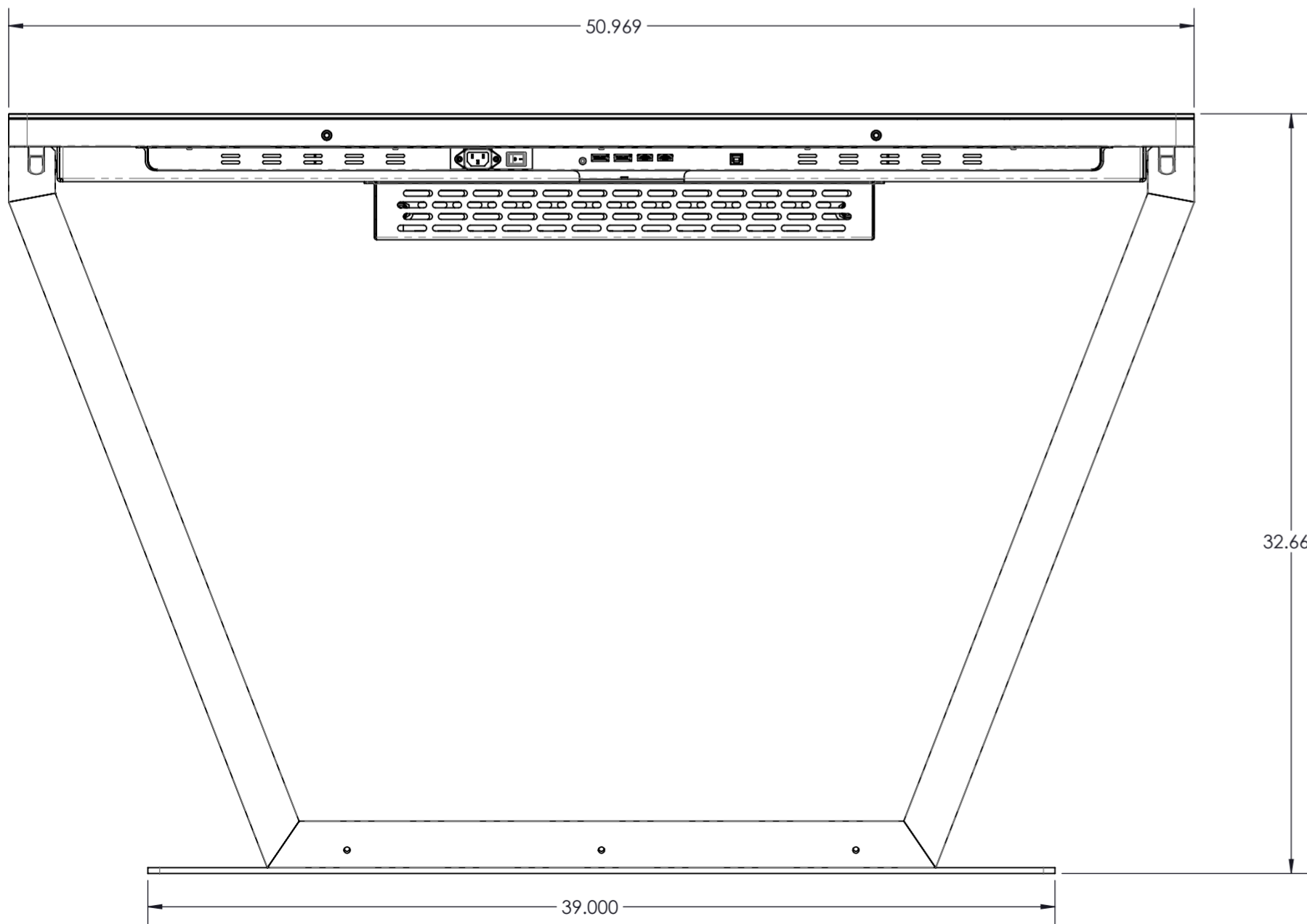

UNLESS OTHERWISE SPECIFIED: DIMENSIONS ARE IN INCHES SURFACE FINISH: TOLERANCES: LINEAR: .01 ANGULAR: .5			FINISH:	DEBUR AND BREAK SHARP EDGES	DO NOT SCALE DRAWING	REVISION
					Digital Touch Systems	
DRAWN:			NAME		TITLE:	
CHK'D:			SIGNATURE		DWG NO. DTS-55-LKN A2	
APP'VD:			DATE		SCALE: 1:16	
MFG:					SHEET 5 OF 6	
Q.A.			MATERIAL:			
			WEIGHT:			

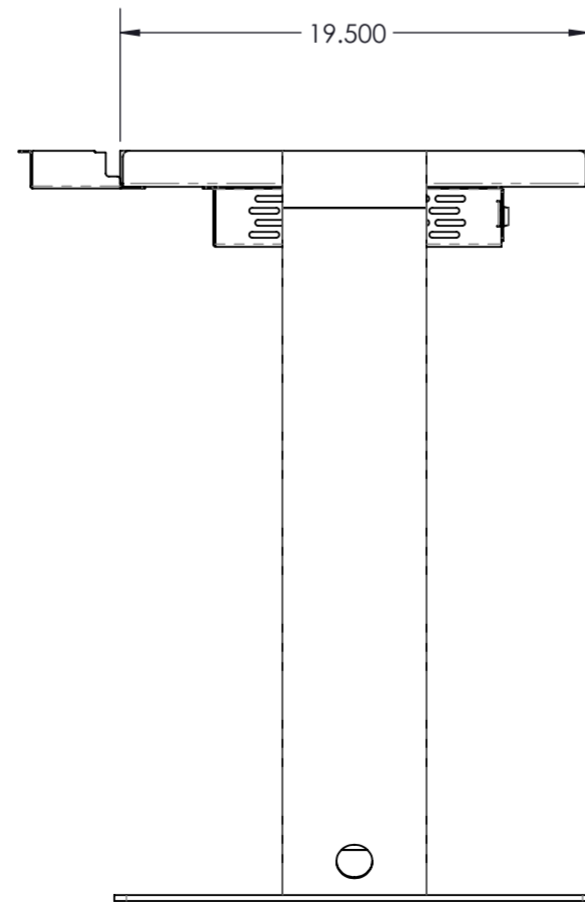
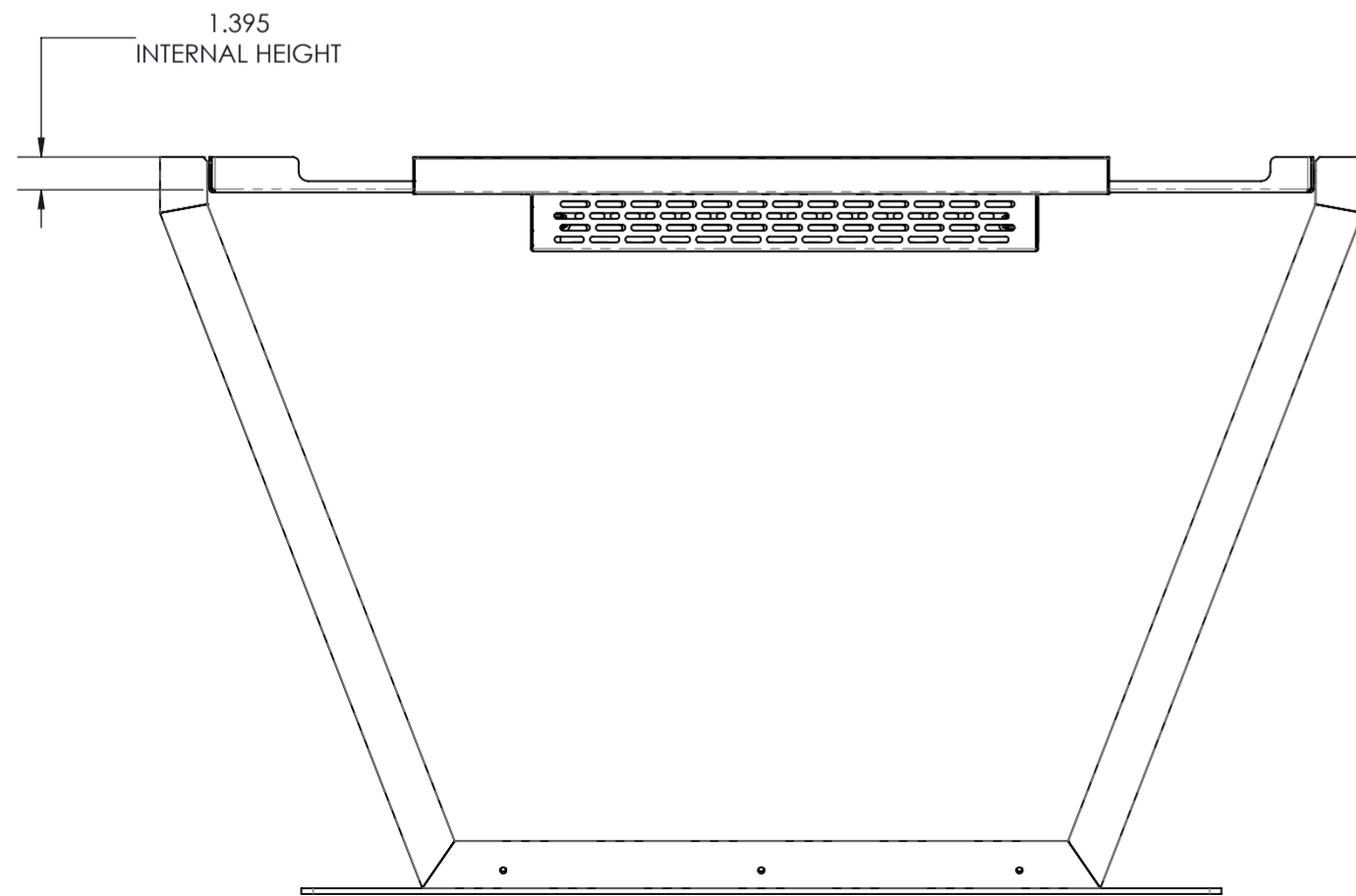
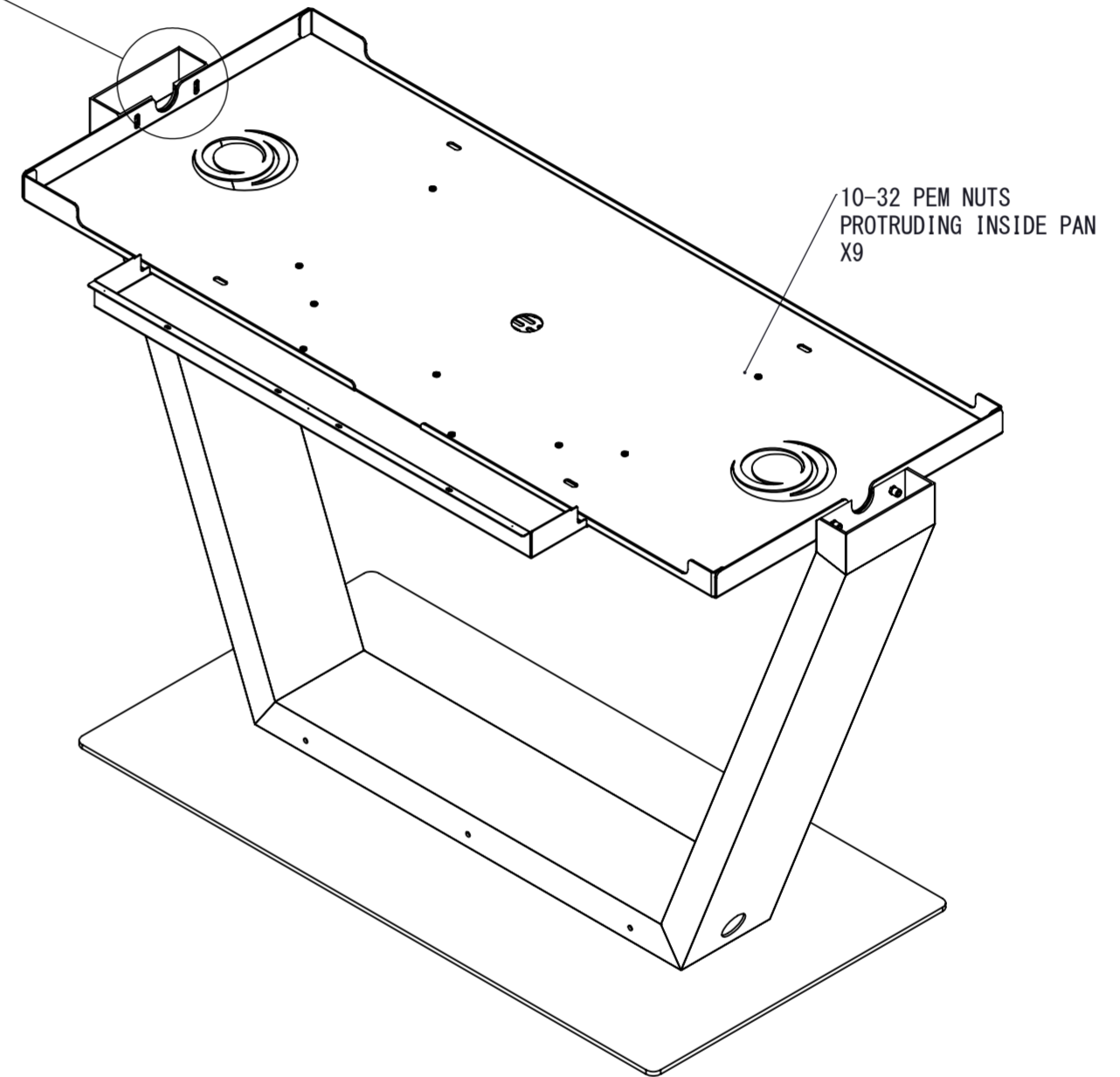
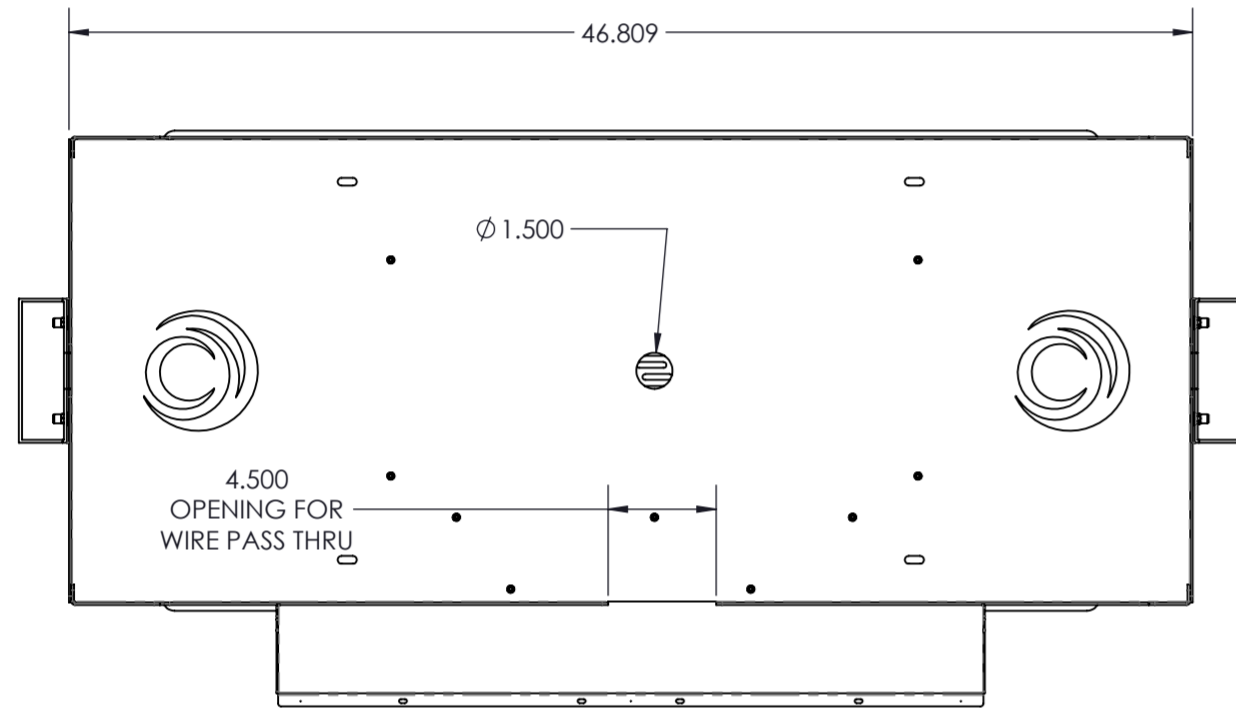
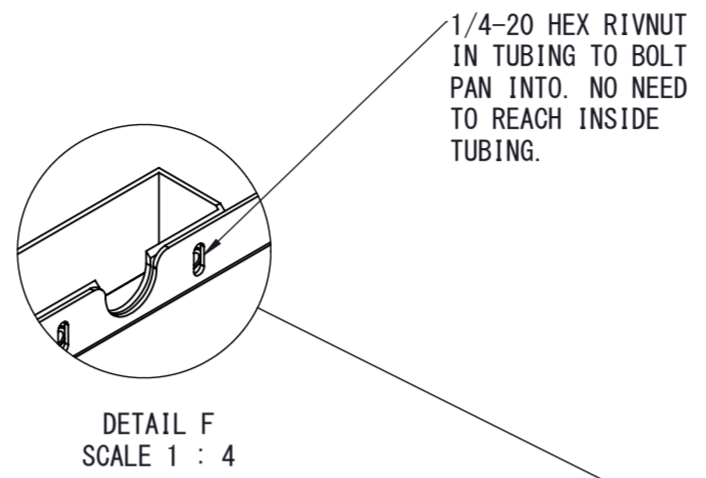

UNLESS OTHERWISE SPECIFIED: DIMENSIONS ARE IN INCHES SURFACE FINISH: TOLERANCES: LINEAR: .01 ANGULAR: .5		FINISH:	DEBUR AND BREAK SHARP EDGES		DO NOT SCALE DRAWING	REVISION
					Digital Touch Systems	
					TITLE:	
DRAWN:	NAME	SIGNATURE	DATE		DWG NO.	DTS-55-LKN
CHK'D:						A2
APP'V'D:						
MFG:						
Q.A.				MATERIAL:		
				WEIGHT:	SCALE: 1:16	SHEET 6 OF 6